

• P E R S O N A L S E R I E S •

AbCoaster

**OWNER'S
MANUAL &
TRAINING
GUIDE**



Maximum User
Weight is 300 lbs.

The Fast Track to Great Abs™

CONTENTS

- 3 Important Safety Information
- 4 Assembly Instructions
- 6 Adjusting the Seat
- 6 Getting On and Off the Ab Coaster®
- 7 Ab Coaster® Exercises
 - a. Forward Lift
 - b. Side Lift (Obliques)
 - c. “Free-Style Motion” Training
 - d. Resistance Training
- 10 Digital Counter
- 10 Moving, Storing and Maintaining the Ab Coaster®
- 11 Parts List and View

SAFETY LABELS

CAUTION: PINCH POINT

Keep hands away and stand clear of machine while in use.

WARNING

Make sure locking pin is fully engaged before beginning forward and side lift exercises.



WARNING

SERIOUS INJURY COULD OCCUR IF THESE PRECAUTIONS ARE NOT OBSERVED.

Read the Owner's Manual prior to using this machine.

Obtain a medical exam prior to beginning an exercise program.

Keep head, limbs, fingers and hair clear of all moving parts.

Inspect machine prior to use. Do NOT use if it appears damaged or inoperable.

Use the machine only for intended use.

Use caution getting on and off machine.

Do not allow children near this machine.

PARTS LIST AND VIEW

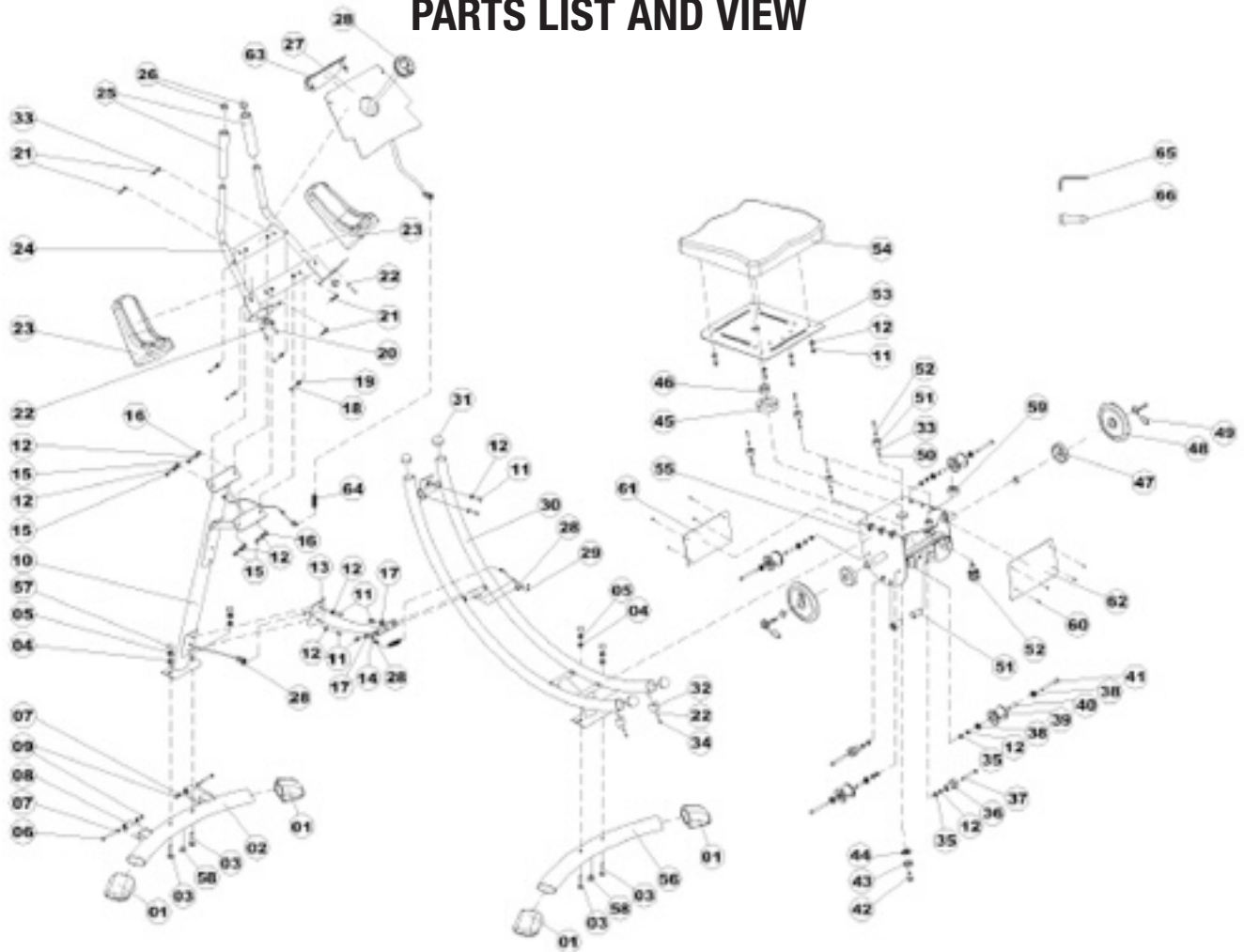

NO.	Part Name	Specification	QTY (PCS)	NO.	Part Name	Specification	QTY (PCS)	NO.	Part Name	Specification	QTY (PCS)
01	foot grip match	70*35*1.5 elliptical tubing	4	23	arm cushion		2	45	nylon bushing	ø70*ø40*20	1
02	front leg		1	24	handlebar frame		1	46	ø38 nylon sleeve	ø38*ø25*19	2
03	M10*45 screw	M10*45(15mm thread)	4	25	handlebar grip	ø29*ø23*220	2	47	weight post collar	ø70*8	2
04	R71 arc washer	ø25*d10*2.0_R71	4	26	circular piston match	ø25.4*1.5 tubing	6	48	weight plate (not included)	2.5KG/pcs, ø26.5	4
05	M10 nut	M10	4	27	arm plate	337*267*_24	1	49	weight plate clip (not included)	ø25.4*1.5_	2
06	M6*50 flanged-hex screw	M6*50(15mm thread)	2	28	counter including sensor, magnet, and ø76 wire		1set	50	M5 nut	M5	4
07	ø13 flat washer	ø13*d6*1.2	4	29	M3*6 phillips screw	M3*6	2	51	seat swivel bushings	ø25*20	4
08	front leg wheel	ø20*ø7*25	2	30	ab coaster track		1	52	M5*20 phillips screw	M5*20	4
09	m6 nut	M6	2	31	ball piston match	ø38*1.5 tubing	4	53	seat plate		1
10	front support post		1	32	bumper	ø32*26.5	2	54	seat cushion		1
11	M8*15 hex screw	M8*15	10	33	ø10 flat washer	ø10*d5*1.0	12	55	U shape seat carriage		1
12	ø16 flat washer	ø16*d8*1.5	22	34	M5*10 phillips screw	M5*10	2	56	rear leg	70*35*1.5	1
13	front support brace		1	35	M8 nut	M8	6	57	m10 nut	M10	4
14	wire clip	ø15*12	2	36	spacing wheel	ø32*42	2	58	leg support pad	ø25*10	2
15	M8*20 hex screw	M8*20	4	37	M8*65 hex screw	M8*65(15mm thread)	2	59	muffler	ø28*13	1
16	ø8 spring washer	ø8	4	38	bearing	608ZZ_ABEC-5	8	60	ST3.5*10 self-drilling phillips screw	ST3.5*10	8
17	R12.5 ø16 arc washer	ø16*d8*1.5, R12.5	2	39	roller wheel	ø54*48	4	61	front seat cover		1
18	M6*40 hex screw	M6*40	4	40	roller wheel axle	12*1.5*30	4	62	rear seat cover		1
19	R12.7 ø16 arc washer	ø16*d6*1.2_R12.7	4	41	M8*75 hex screw	M8*75_15mm thread)	4	63	front logo plate		1
20	M6*15 screw	M6*15	4	42	M10*25 hex screw	M10*25	1	64	wire protection cover	ø14.2*90*0.8	2
21	ST4.8*15 self-drilling phillips screw	ST4.8*15	4	43	ø10 spring washer	ø10	1	65	tool	A S5	1
22	ø18 flat washer	ø18*d6*1.2	6	44	lifted washer	ø38*ø10.5*2	1	66	tool	B S10/S13/S17	1

D. RESISTANCE TRAINING (Weights Not Included)



Using Added Weight for Resistance: There are 2 weight posts on the sides of the Ab Coaster® Seat for adding weights (not included) for extra resistance during exercise.

CAUTION: Do not add more than 20 lbs. of weight in total to the posts (4 plates of 5 lbs. each). Before adding any weight, ensure that you are able to perform the exercise with proper form without any additional weights.

Please visit www.AbCoaster.com to view video of proper usage of the machine.

DIGITAL REPETITION COUNTER



The digital repetition counter helps to keep your workout on track. You focus on exercising correctly and the counter keeps track of your repetitions.

Requires 2 "AAA" batteries (included).

Press the mode key to start the count function.

**To reset the counter,
press and hold the button for 3 seconds.**

MOVING, STORING AND MAINTAINING THE AB COASTER®



Moving and Storing:

There are 2 wheels attached to the front leg support of the Ab Coaster® in order to aid in the moving and storage of the unit. Stand in the front of the unit and grasp the handle bars.

Push down on the handle bars tilting the rear up until the front wheels are engaged.

For storage, keep the unit in a dry place. If placed in long-term storage, you should

cover the unit with a cloth or other material to protect the unit from excessive dust or dirt accumulation.

Maintenance:

Keep curved track clean and free of debris. Wipe periodically with cloth to keep track smooth and clean.

IMPORTANT SAFETY INFORMATION

IMPORTANT: Please read and follow all instructions thoroughly before using your Ab Coaster®.

- Maximum user weight is 300 lbs.
- ALWAYS USE CAUTION WHEN GETTING ON AND OFF THE AB COASTER®. READ INSTRUCTIONS ABOUT PROPER WAYS TO GET ON AND OFF THE AB COASTER®.
- KEEP BODY PARTS, HANDS AND FEET AWAY FROM THE SEAT, WHEELS AND THE CURVED TRACK WHILE USING THE AB COASTER®. SEVERE INJURY CAN RESULT IF BODY PARTS, HANDS OR FEET ARE PLACED ON TRACK WHILE SOMEONE IS USING THE UNIT.
- KEEP THE AB COASTER® OUT OF THE REACH OF CHILDREN. The Ab Coaster® is not a toy and is not meant to be used by or near children and pets. Please keep children and pets away from the Ab Coaster® and during use, as well as when the product is left unattended. If you have children, it is your responsibility to ensure that they do not place any part of their body such as their fingers near the unit while you are exercising.
- Consult your physician before beginning any exercise or diet program, especially if you have concerns about your physical and fitness levels and overall suitability for exercising with the Ab Coaster®.
- If you experience any pain or unusual discomfort during exercising, stop your workout at once and consult a physician before continuing.
- When using the Ab Coaster®, follow the instructions provided in this booklet. Do not use the product for any other exercises or motions which are not contained herein.
- ONLY USE THE AB COASTER® ON A FLAT, STABLE SURFACE. DO NOT USE THE AB COASTER® ON A SMALL AREA RUG THAT MAY TEND TO MOVE WHILE EXERCISING.
- DO NOT ATTEMPT TO USE THE AB COASTER® WITHOUT RESTING YOUR ARMS ON THE ARM REST AND HOLDING ONTO THE HANDLES.
- Do not pick up the Ab Coaster® to move it. Follow the instructions in this booklet for moving the Ab Coaster®.
- Do not leave the Ab Coaster® in the direct sun for extended periods of time.
- Use only accessories and attachments recommended by the manufacturer. Use of any other attachments or accessories not recommended by the manufacturer will void the warranty and could possibly cause serious personal injury or damage to you and the unit.
- Always choose the proper workout level which best suits your physical strength and flexibility.
- Know your limits and train within them. Always use common sense when exercising. If you have any questions regarding your exercise program, please see your physician.
- DO NOT USE THE Ab Coaster® if it is damaged in any manner. Inspect before each use. Failure to observe this warning could result in personal injury while exercising.
- Use the machine only for intended use as described herein. DO NOT modify the machine.
- Do not replace any parts with parts from other equipment or other manufacturers. Use only parts provided by the manufacturer.
- **This product is intended for Residential use only and is not intended for commercial facilities such as Health Clubs, Hotels or Fitness Centers.**

SAVE THESE INSTRUCTIONS AND ENSURE THAT OTHER EXERCISERS READ THESE INSTRUCTIONS PRIOR TO USING THE AB COASTER® FOR THE FIRST TIME.

ASSEMBLY INSTRUCTIONS

Your Ab Coaster® has been thoroughly inspected and partly assembled before shipment. You will need to take a few additional steps as described below to complete assembly. If you have any questions, please call our customer service center at 973-287-5100.

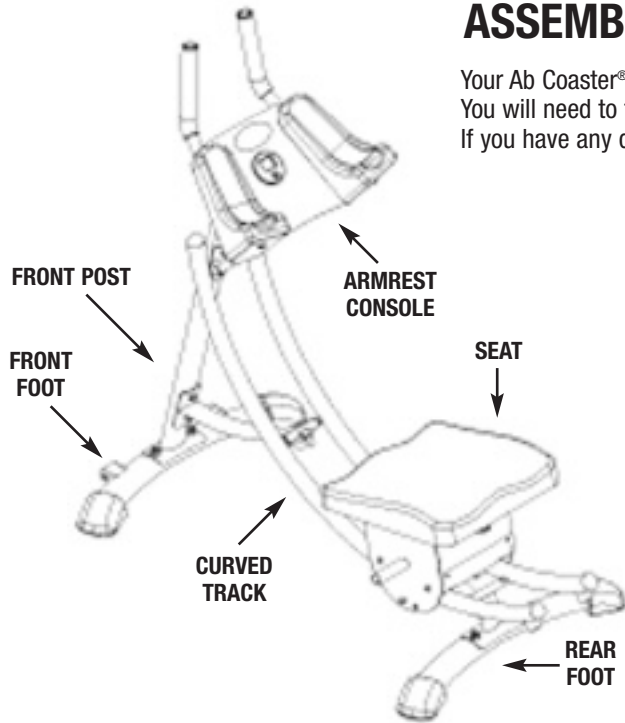

Step 1: Attach Rear Foot

Step 2: Attach Front Foot

Step 3: Attach Front Post

Step 4: Attach Armrest Console

Step 5: Connect Wires

IMPORTANT: Remove all parts from packing and inspect for damage. Retain packing materials if possible.

Step 1: Attach rear foot (without wheels) to rear of curved track. Remove the 2 bolts which have been pre-attached to the rear foot, then re-attach the bolts to connect foot to track. Finger tighten bolts only. Do not tighten bolts with tool until unit is fully assembled.

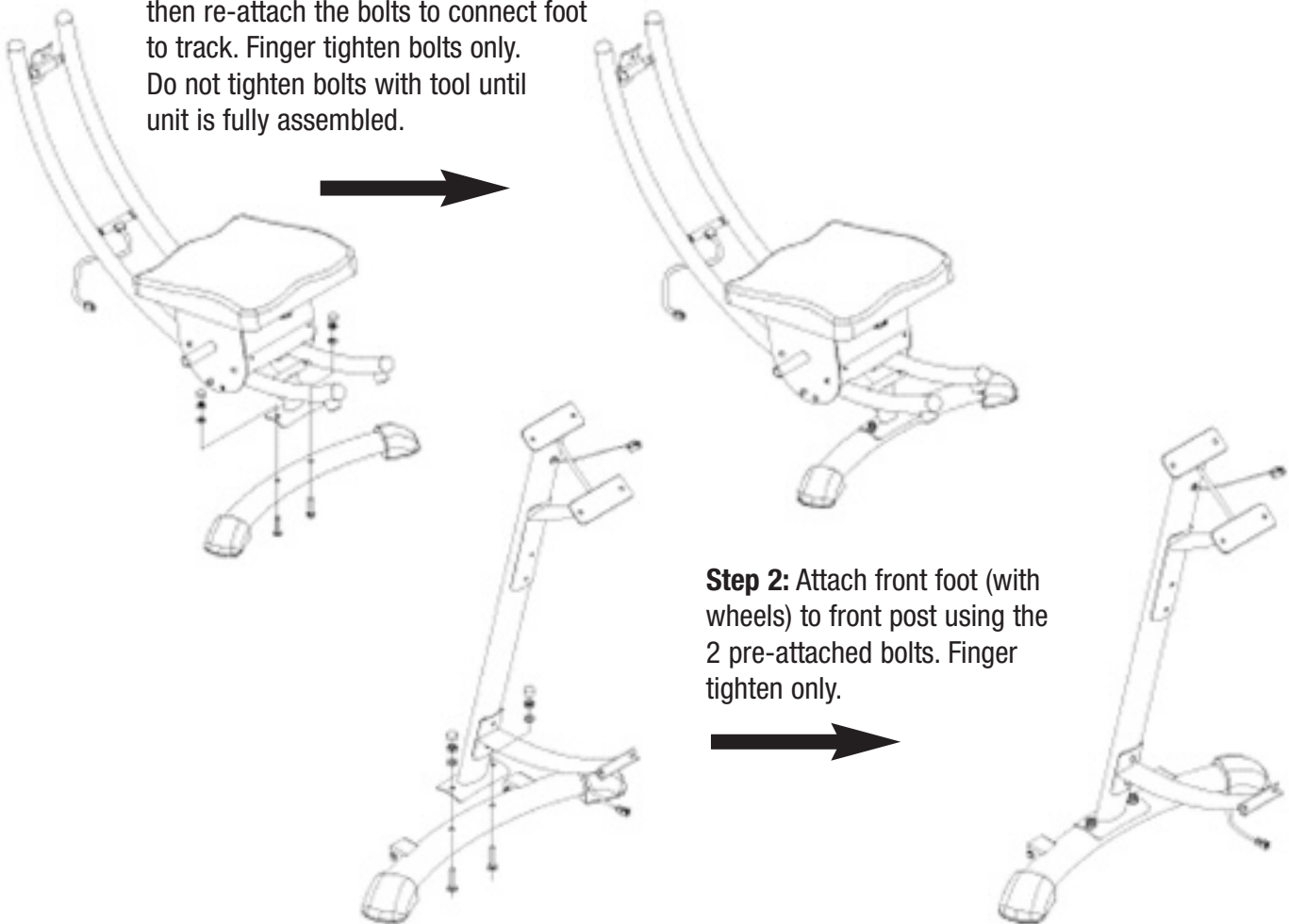

Step 2: Attach front foot (with wheels) to front post using the 2 pre-attached bolts. Finger tighten only.

C. FREE-STYLE MOTION TRAINING



WARNING: Free-Style Motion Training is an advanced exercise. Do not attempt Free-Style Motion exercise until you have mastered the Forward and Side Lift exercises and you feel comfortable using the machine.



1. Adjust pull pin under the Seat so that it is in the “unlocked” mode.
2. **Prior to kneeling on Seat**, place forearms and elbows on arm pads. Grasp handles firmly to balance your body prior to kneeling on Seat.
3. Kneel on Seat so that your feet are hooked on the back edge of the pad. **WARNING: Use caution when kneeling on seat in “unlocked” position; make sure you move slowly and grasp handles first to keep your body steady before kneeling on the Seat. DO NOT kneel on Seat before you grasp the handles and stabilize your upper body first.**
4. In “Free-Style Motion” position, you may create your own workout and use a variety of forward and side lifts. You can twist your core as you rotate the Seat from side to side through the range of motion along the track. (visit www.AbCoaster.com for sample Free-Style Workouts)
5. While exercising in the Free-Style Motion position, keep the speed of exercise at a steady rate. Lift and return the Seat using steady and slow speed. Do not use momentum to lift – concentrate on contracting and using your abs to lift.

Do not use excessive force when lifting or returning Seat to starting position and avoid banging Seat against the track.

CAUTION: DO NOT LEAVE THE AB COASTER® SEAT “UNLOCKED” IN THE FREE-MOTION SETTING WHEN YOU ARE FINISHED WITH EXERCISE. LOCK THE SEAT INTO A FIXED POSITION AFTER YOU COMPLETE EXERCISE.

B. SIDE LIFT– FOR OBLIQUES (LEFT AND RIGHT)



1. Adjust Seat to the side you want to work (left or right). Make sure Seat pin is in “locked” position and the Seat is not moving freely.
2. Follow Steps 2 - 6 from the Forward Lift exercise above.
3. During exercise, focus on contracting the oblique muscles to lift. After completing one side, adjust the seat and perform Side Lift exercise for other side (left or right).



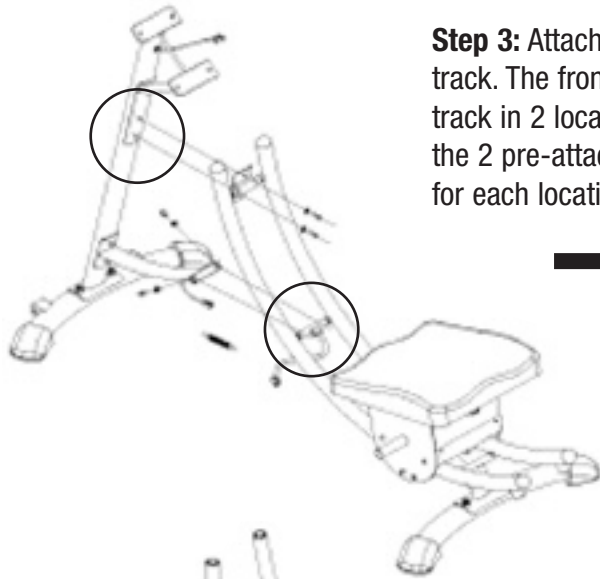

Step 3: Attach front post to curved track. The front post is attached to track in 2 locations as shown using the 2 pre-attached Allen head screws for each location. Finger tighten only.

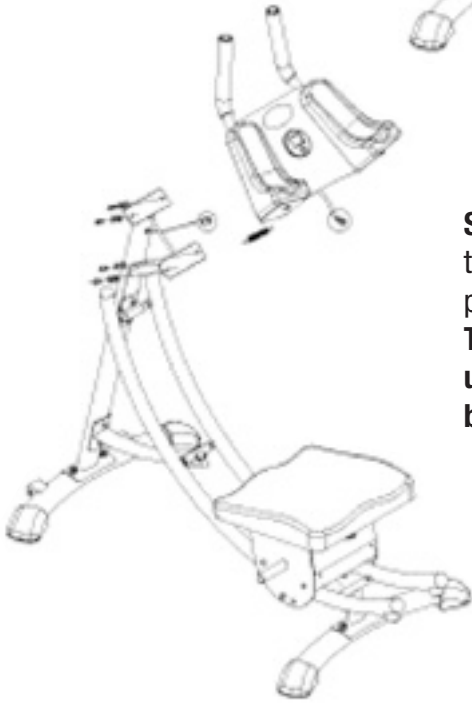
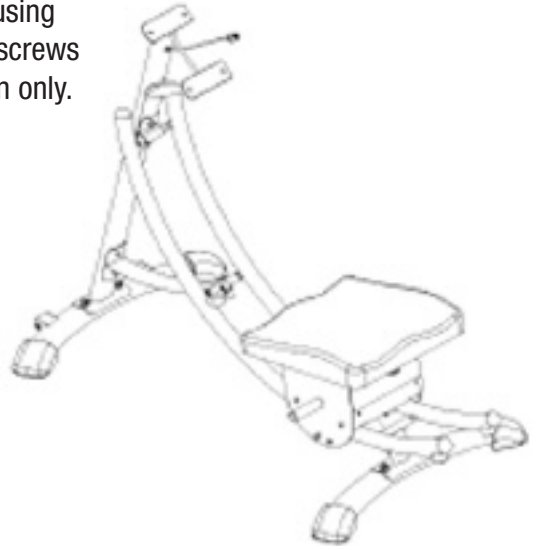

Step 4: Attach armrest console to top of front post using the 4 pre-attached Allen head screws. **Tighten all bolts and screws using tools provided. Cover bolts with black plastic caps.**



Step 5: Connect counter wires in 2 locations as shown. Install wire protection covers to cover wire connections.





ADJUSTING THE SEAT

The Seat on your Ab Coaster® can be adjusted to target different areas of your abdominal muscle. The Seat adjustment pin is located at the rear of the Seat below the cushion.

There are 4 Seat settings: Front, Left, Right and Free-Style Motion.

To lock the Seat into the Front, Right or Left settings, pull down the pin and move the Seat to the desired setting (Front, Right or Left). Release the pin and adjust the Seat until the pin “pops” into the hole underneath the Seat at the desired setting. Make sure the pin is in the “locked” position and the Seat is secure before you use the Ab Coaster®.

To adjust the Seat for the Free-Style Motion setting, pull down the pin and twist the pin to the “unlocked” setting. Rotate the Seat by hand to ensure that it is moving freely.



Unlocked position is for Free-Style Motion.

GETTING ON AND OFF THE AB COASTER®



Step 1: Make sure the Ab Coaster® is placed on a flat, stable surface.

Step 2: Approach the Ab Coaster® from the side, not the back, of the unit.

Step 3: Place forearms and elbows on arm pads. Grasp handles to maintain your balance.

Step 4: While grasping handles, place knees on Seat so that your feet are hooked on the back edge of the seat. You are now ready to exercise.

CAUTION:

Getting On and Off the Ab Coaster® When Seat is in “Unlocked” Free-Style Motion Position: Use extra caution when getting on or getting off Ab Coaster® while Seat is “unlocked” in Free-Style Motion setting. Since the Seat is not fixed and locked while in the Free-Style Motion position, make sure you move slowly and grasp handles first to keep your body steady before kneeling on the Seat. DO NOT kneel on Seat before you grasp the handles and stabilize your upper body first. Grasping handles first will help prevent you from losing your balance.



1 - Foot should be hooked on back edge of seat.

2 - Do not lean forward; sit back toward your heels.

AB COASTER® EXERCISES

How It Works: The Ab Coaster® is designed to help you exercise your abdominal muscles via a leg lift motion. Unlike the popular sit-up or ab crunch exercise, which works your abdominals from the “top down”, the Ab Coaster® moves in the opposite direction, working your abs from the “bottom up.” The basic motion requires you to lift your knees and legs while contracting your abs.

The Ab Coaster® features a Seat moving along a curved track to aid you in performing the abdominal lifting motion. The starting position requires you to kneel on the Seat while resting your arms on the arm rests. The exercise requires you to lift the Seat along the track by using your abdominal muscles, not by using your arms or your upper body. The key to performing the exercise properly is to concentrate on contracting your ab muscles prior to and while you lift the Seat. Your upper body should be stable and should not be moving or swaying while you exercise.



A. FORWARD LIFT



1. Adjust Seat so that it faces forward.
2. Place forearms and elbows on arm pads. Lightly grasp handles.
3. Kneel on Seat so that your feet are hooked on the back edge of the pad. DO NOT lean forward; sit back toward your heels.
4. While contracting your abs, lift your knees forward along the track. DO NOT move your upper body while performing exercise. Make sure you use your abs to lift the Seat carriage; DO NOT use your upper body or your arms to lift.
5. Return slowly to starting position, and repeat.
6. Use steady and slow speed while exercising. DO NOT use momentum to lift – concentrate on contracting and using your abs to lift.

Do not use excessive force when lifting or returning Seat to starting position and avoid banging Seat against the track.

We are very proud of the design and quality of the Ab Coaster[®]. This product has been manufactured to the highest standards. Should you have any problem our friendly customer service staff is here to help you if you have a question.

We are available at:

800-526-3037

8:00 am – 9:00 pm EST Monday – Friday
9:00 am – 5:00 pm EST Saturday & Sunday

www.abcoaster.com

© 2008 TRISTAR PRODUCTS, INC.
ALL RIGHTS RESERVED.

© 2008 Ab Coaster, LLC All Rights Reserved | U.S. Pat. No. D565,134 and other Patents Pending
U.S. Trademark Registration Numbers 3407362 and 2632152



Distributed by: Tristar Products, Inc., Fairfield, NJ 07004

V3 071408