

TORSO ROTATION

PRODUCT NO. 12190

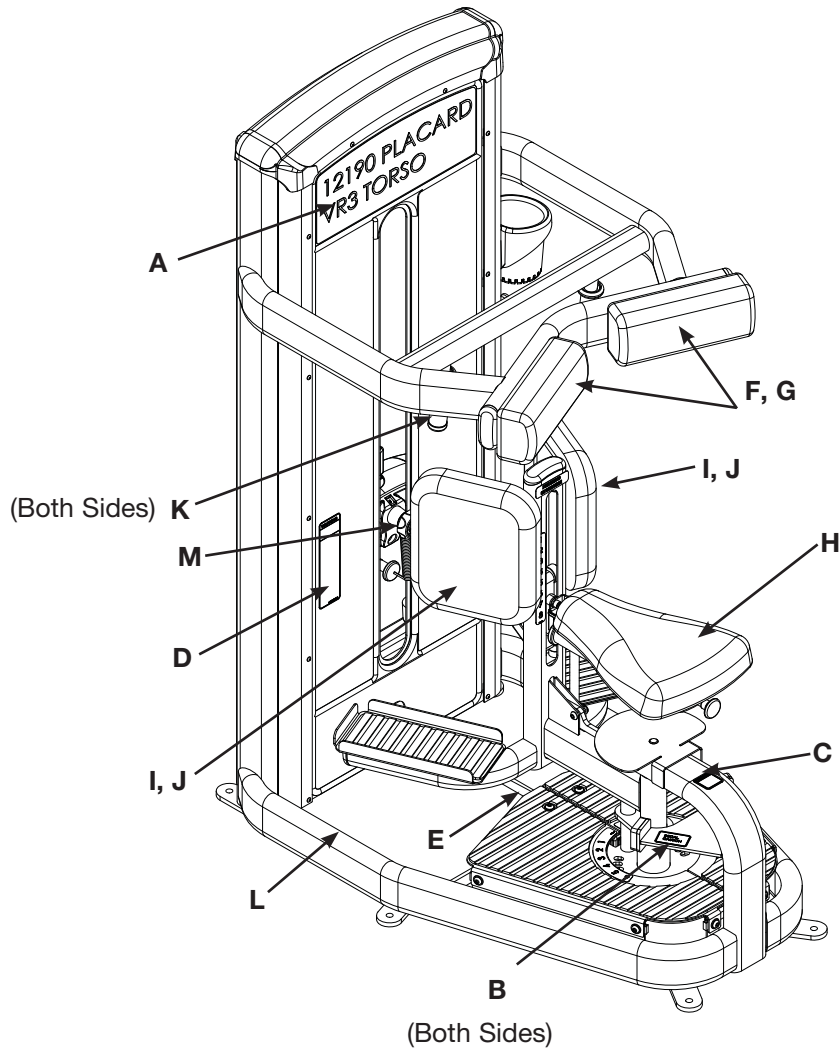

NOTE: See exploded-view diagram for location of L (serial number decal), E. (belt) and N (increment weight decal).

DESCRIPTION	PART NO.	DESCRIPTION	PART NO.
A. Placard Decal	12190-498	H. Seat Pad	4800-172
B. Caution Decal	4000Y316	I. Thigh Pad w/Wear Cover..	4201S065-0
C. Caution Decal	4520-362	J. Wear Cover.....	4201S076-0
D. Warning Label	4605-381	K. Grip	4605-510
E. Weight Stack Belt.....	GB000202	L. Serial Number Decal	
F. Chest Pad w/Wear Cover...	4800-023	M. Weight Selector Pin.....	BH030207
G. Wear Cover	4800-095	N. Increment Weight Decal.....	11000-407

Cybox VR3 Torso Rotation Owner's Manual

ITEM	QTY	PART NO.	DESCRIPTION	ITEM	QTY	PART NO.	DESCRIPTION
1	1	01989	CONNECTING LINK, SINGLE	54	1	CM000211	DECAL, PATENT PENDING
2	1	11040-301	CLAMP BLOCK INSERT	55	1	EZ000008	GAS SPRING 250N
3	2	11040-440	KNOB	56	2	FB030240	BEARING, TAPPED ROLLER
4	1	11040-560	DECAL, WEIGHT PLATE (10 - 290)	57	2	FB130206	BEARING, FLANGE 2.00 ID. x 2.25 OD. x 1.00 LG
5	2	11090-374	END CAP	58	2	FB130209	BRG, FLG .375 X .500 X .125
6	2	11090-376	RING, HANDLE GRIP	59	1	FB130210	BEARING, NYLINER
7	1	12000-344	INSERT, PLASTIC	60	2	FC030006	TOLERANCE RING 1.575 ID
8	1	12000-380	PANEL INSERT	61	2	FO100010	O-RING #121 (1.049 X .103)
9	2	12000-392	CHANNEL, INCREMENT WEIGHT	62	114"	GB000202	WEIGHT STACK BELT .95 WIDE
10	1	12000-395	TOP CAP	63	1	GP000212	PULLEY ASSEMBLY-3.50
11	2	12000-396	END CAP	64	2	GP000214	PULLEY ASSEMBLY - 2.75
12	4	12000-398	SPACER	65	2	HC700415	BHSCS .375-16 X .75
13	4	12050-346	WHEEL, PLASTIC ROLLER	66	7	HC700417	BHSCS .375-16 X 1.00
14	1	12050-348	GUIDE, ROLLER	67	2	HC700428	BHSCS .375-16 X 2.25
15	1	12070-329	DECAL, ADJUSTING	68	4	HC700430	BHSCS .375-16 X 2.50
16	1	12070-394	DECAL, INDICATOR	69	2	HF449063	INSERT 3/4 X 1/4-20
17	6	12090-322	FOOT PAD	70	12	HF579000	PANEL FASTNER, 10-24 U TYPE
18	6	12100-303	BUMPER	71	6	HF700000	PANEL FASTNER, .375-16 , U TYPE
19	1	12190-200	FRAME	72	1	HN-60065	NUT, HEX SELF- LOCKING .312-18 BLK ZINC
20	1	12190-202	PIVOT	73	4	HN704901	LOCKNUT, .375-16 NYLON
21	1	12190-203	CAM	74	1	HP286715	PIN, .188 DIA x .75 ROLL
22	1	12190-204	BELT CLAMP	75	1	HS328300	LOCKWASHER SPLIT .312
23	1	12190-205	PIVOT SHAFT	76	10	HS347600	WASHER, SAE .375
24	1	12190-206	SEAT	77	10	HT512517	TAP SC 10-24 X 1.00 TYPE WB PN HD PHIL BLK
25	1	12190-208	DETENT BAR	78	12	HX570412	BHSCS, 10-24 X .50, SS
26	1	12190-306	PULLEY ASSEMBLY-3.00 (FLAT)	79	2	HX-60184	BALL STUD, .312 - 18 UNC x 10 mm
27	1	12190-310	SLEEVE	80	2	HX620420	BHSCS .250-20 X 1.250 SS
28	1	12190-333	GUARD	81	2	HY740000	SET SCREW
29	1	12190-341	EXTENSION SHAFT	82	2	JC620415	BHSCS .250-20 X .75
30	1	12190-344	ROD	83	2	JC620422	BHSCS .250-20 x 1.50
31	1	12190-348	NON-SLIP	84	3	JC700412	BHSCS .375-16 X .50
32	1	12190-349	NON-SLIP	85	13	JC700420	BHSCS .375-16 X 1.25
33	1	12190-351	GUARD	86	4	JD383315	SHOULDER BOLT .500 x .75 .375-16 UNC
34	1	12190-353	PIVOT BAR	87	14	JS347400	LOCKWASHER, INT TOOTH .375
35	1	12190-354	GAS SPRING MOUNT	88	3	PP130002	INSERT, DOMED PLASTIC
36	1	12190-357	EXTENSION SHAFT	89	2	PP130003	INSERT, DOMED PLASTIC
37	1	12190-358	DECAL, START POSITION	90	2	PR060005	BUMPER, WEIGHT
38	1	12190-359	DECAL, START POSITION	91	1	4605-510	GRIP 1.38 OD X .94 ID
39	1	12190-598-X*	PLACARD VR3 TORSO	92	2	PU060204	BUMPER
40	1	12190-999-X*	OWNER'S MANUAL	93	2	4800-023	CHEST PAD W/WEAR COVER
41	2	12210-347	GUIDE ROD CAP	94	2	4800-095	WEAR COVER
42	2	12210-348	GUIDE ROD CAP	95	1	4800-172	SEAT PAD
43	2	12210-350	WT ROD .625 DIA X 49.53	96	2	4201S065-0	THIGH PAD W/WEAR COVER
44	2	4505-329	PIN,DETENT	97	2	4201S076-0	WEAR COVER
45	1	4605-381-X*	WARNING LABEL	98	1	4520-362-X*	DECAL, CAUTION
46	2	4710-321	NON - SLIP	99	2	4000Y316-X*	DECAL, CAUTION
47	2	4715-336	WASHER	100	1	11000-407-X*	DECAL, INCREMENT WEIGHT
48	1	4715-341	DECAL, DETENT	101	1	13000-402	WATER BOTTLE HOLDER MOUNT
49	2	4715-346	COMPRESSION SPRING .72 x 1.50 LG	102	1	13000-400	WATER BOTTLE HOLDER
50	1	51198	WARRANTY BOOK (NOT SHOWN)	103	1	HT552515	TAP SCREW 8-16 X .75
51	2	BR030210	RETAINING RING, 17mm				
52	2	BR030213	RETAINING RING, 2.00 EXTERNAL				
53	2	BS070208	COMPRESSION SPRING				

***Language Key**

1-German
 2- French
 3-Spanish
 4-English
 6-Japanese
 7-Swedish
 8-Russian

TORSO ROTATION MAIN ASSEMBLY DETAIL

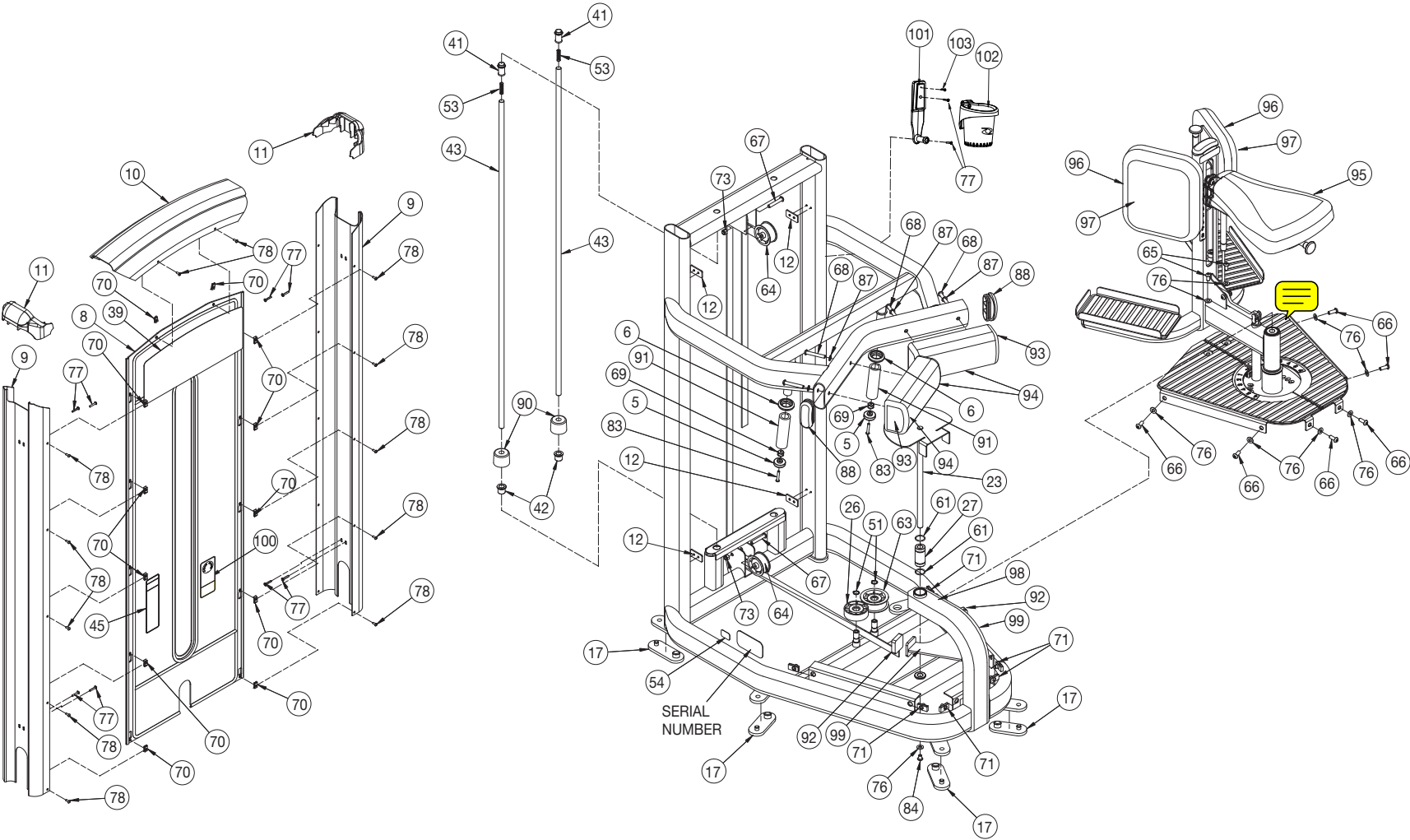

**TORSO ROTATION
SEAT ASSEMBLY DETAIL**

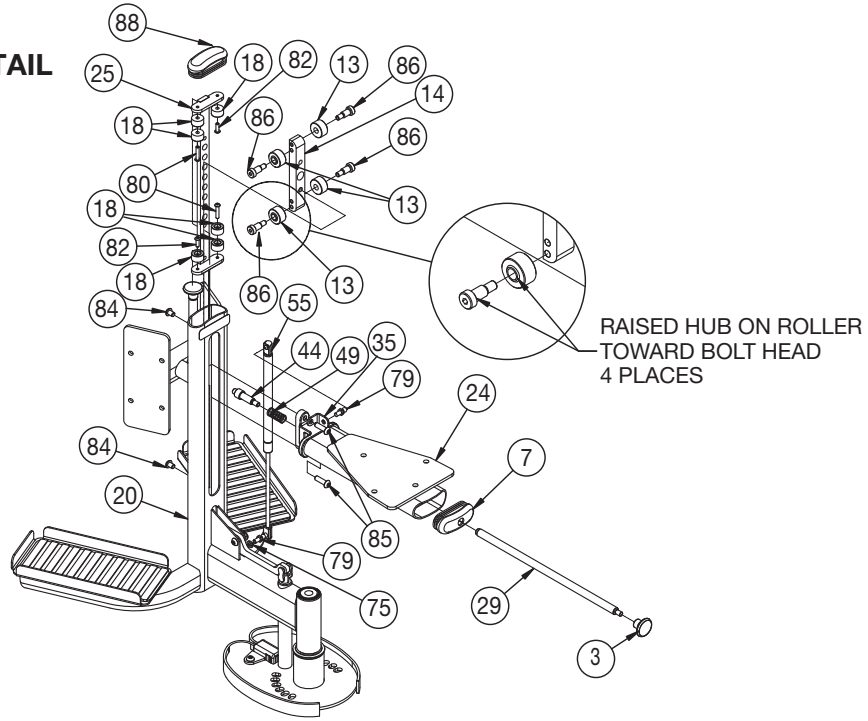

**TORSO ROTATION
PIVOT ASSEMBLY DETAIL**

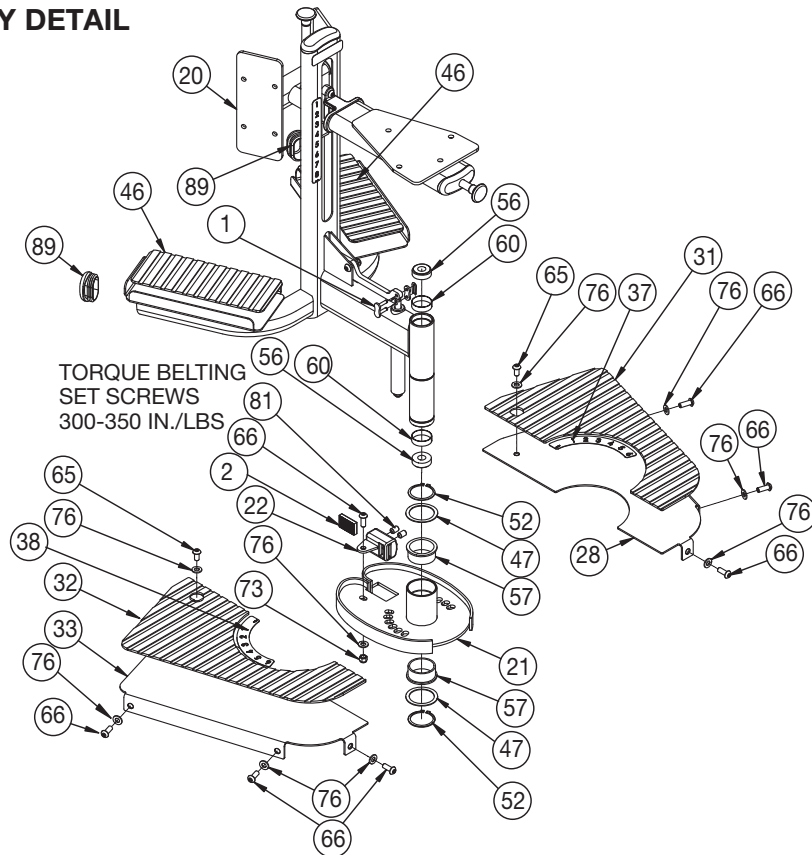

**Light Stack Assembly Configuration
12070-020**

ITEM	QTY	PART NO.	DESCRIPTION
1	1	11040-006	Top Weight Assembly 10
2	1	12000-375	Panel, Insert
3	1	12000-378	Support
4	2	12000-387	Extrusion, Inc Wt Channel
5	2	12102-330	Insert, Increment Weight
6	2	12102-352	Plastic Insert
7	2	12210-358	Spacer Tube
8	1	3900-441	Decal, Cybex
9	10	HF579000	Panel Fastner, 10-24 U Type
10	2	HS760106	Washer, Flat, 1.75 X .688 X .140 T
11	13	HX570412	BHSCS, 10-24 X .50, SS
12	2	JS497600	Washer, 1.19ID X 1.75 OD X .12 THK
13	2	11040-409	Molded Bumper
14	3	HY740000	Set Screw
15	1	11040-216	Belt Clamp
16	1	11040-301	Belt Clamp Insert

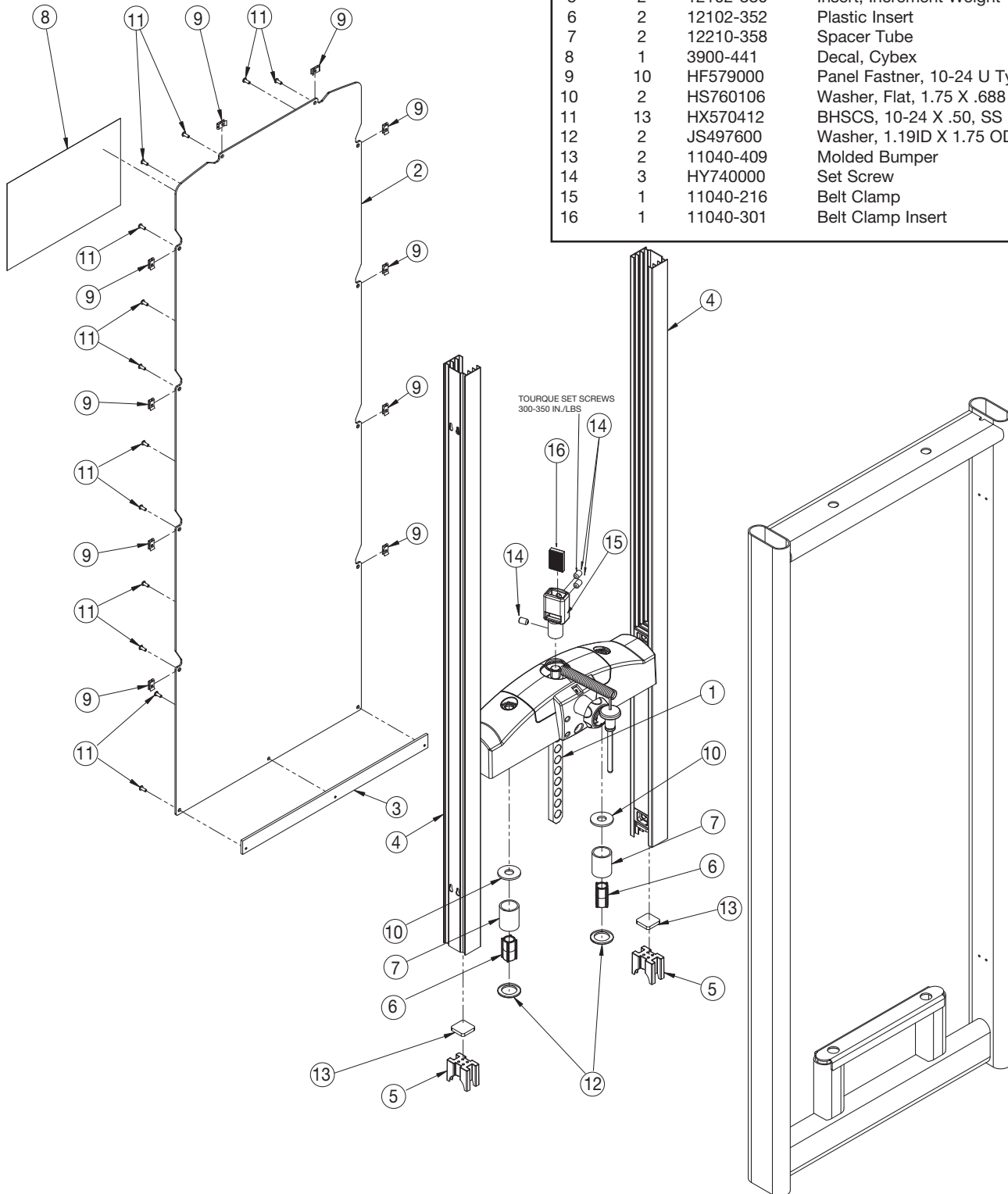

**Heavy Stack Assembly Configuration
12070-021**

ITEM	QTY	PART NO.	DESCRIPTION
1	1	11040-006	Top Weight Assembly 10
2	1	12000-375	Panel, Insert
3	1	12000-378	Support
4	2	12000-387	Extrusion, Inc Wt Channel
5	2	12102-330	Insert, Increment Weight
6	1	3900-441	Decal, Cybox
7	10	HF579000	Panel Fastner, 10-24 U Type
8	13	HX570412	BHSCS, 10-24 X .50, SS
9	2	11040-409	Molded Bumper
10	3	HY740000	Set Screw
11	1	11040-216	Belt Clamp
12	1	11040-301	Belt Clamp Insert

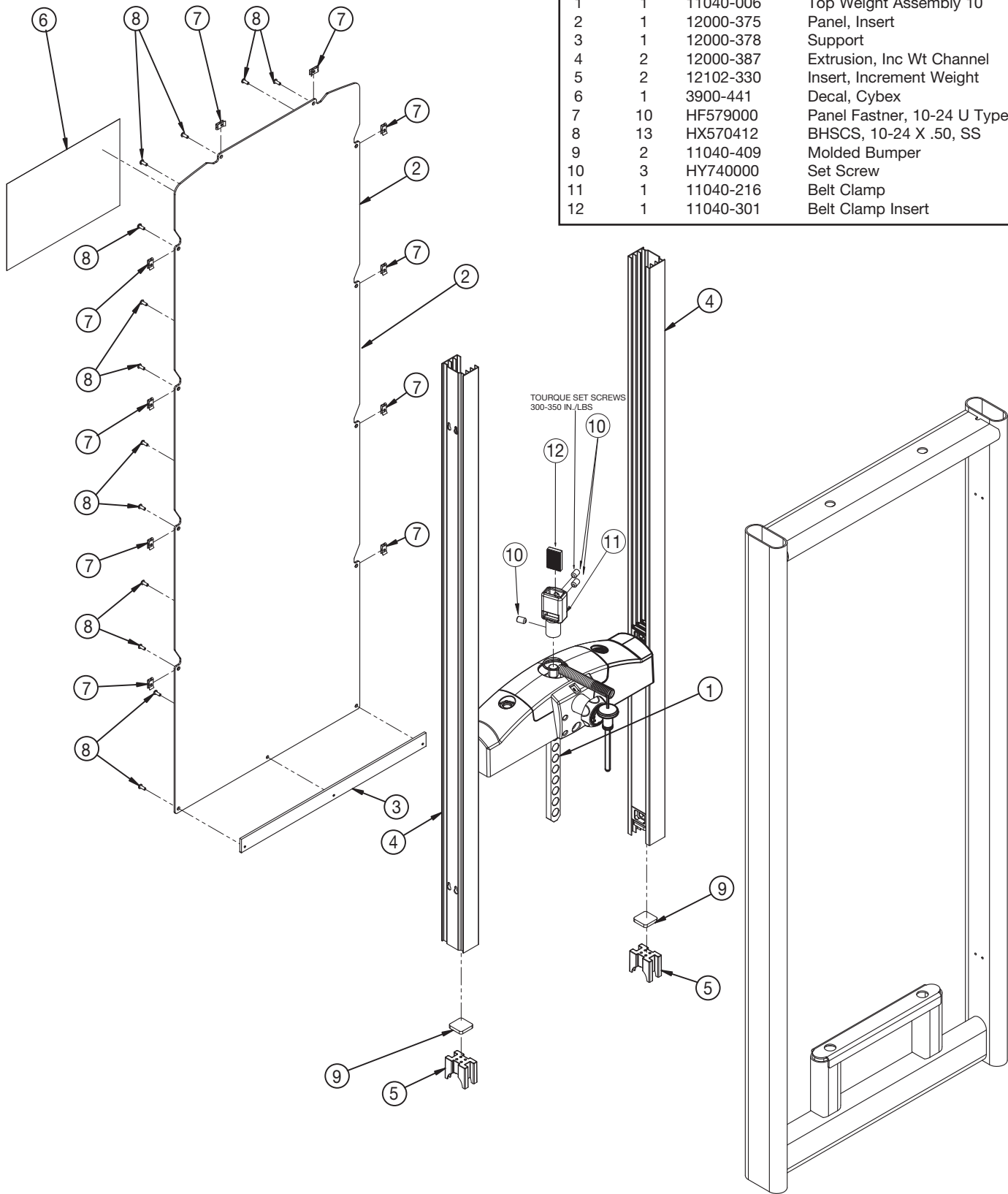

Top Weight Assembly (Light Stack and Heavy Stack Configurations)

ITEM	QTY	PART NO.	DESCRIPTION
1	1	11040-366	Top Weight Assembly, Molded
2	1	11040-367	Hub, Molded
3	2	11040-369	Rod, Linkage
4	2	11040-370	Pin
5	1	11040-427	Rod
6	1	11040-426	Stem
7	1	11040-424	Cover Plate
8	1	11040-416	Cover, Top Weight
9	1	11040-425	Knob
10	1	BH030207	Pin, Weight Selector
11	1	4700-251	Lifting Post 15
12	4	BR030209	External Retaining Ring .188
13	2	BR030220	Internal Retaining Ring 1.250
14	1	HP016820	Cotter Pin .125 X 1.25
15	1	HP266765	Roll Pin, .125 X .938
16	2	HS720004	Felt Washer, .641 1.250 .125 T

ITEM	QTY	PART NO.	DESCRIPTION
17	4	HT562715	Tap SC NO 10 x .750 F Phil
18	4	HT582510	Tap SC NO 10 x .375 PN HD Phil
19	2	11040-409	Molded Bumper Pad
20	12	11040-572	Guard, Increment Weight
21	6	11040-573	Weight Increment
22	1	11040-216	Belt Clamp
23	1	11040-301	Clamp Block Insert
24	1	11040-428	Adjustment Decal
25	1	11040-429	Rotation Decal
26	1	HT552512	Screw, Pan HD Phil HD Self Tapping 8-16 x .50, Type WB
27	3	HY740000	Set Screw
28	7	4000C101	Weight Plate Light Stack
28	9	4000C101	Weight Plate Heavy Stack
29	1	12050-006	Light Weight Pack (Not Shown)
30	1	4701-011	Heavy Weight Pack (Not Shown)

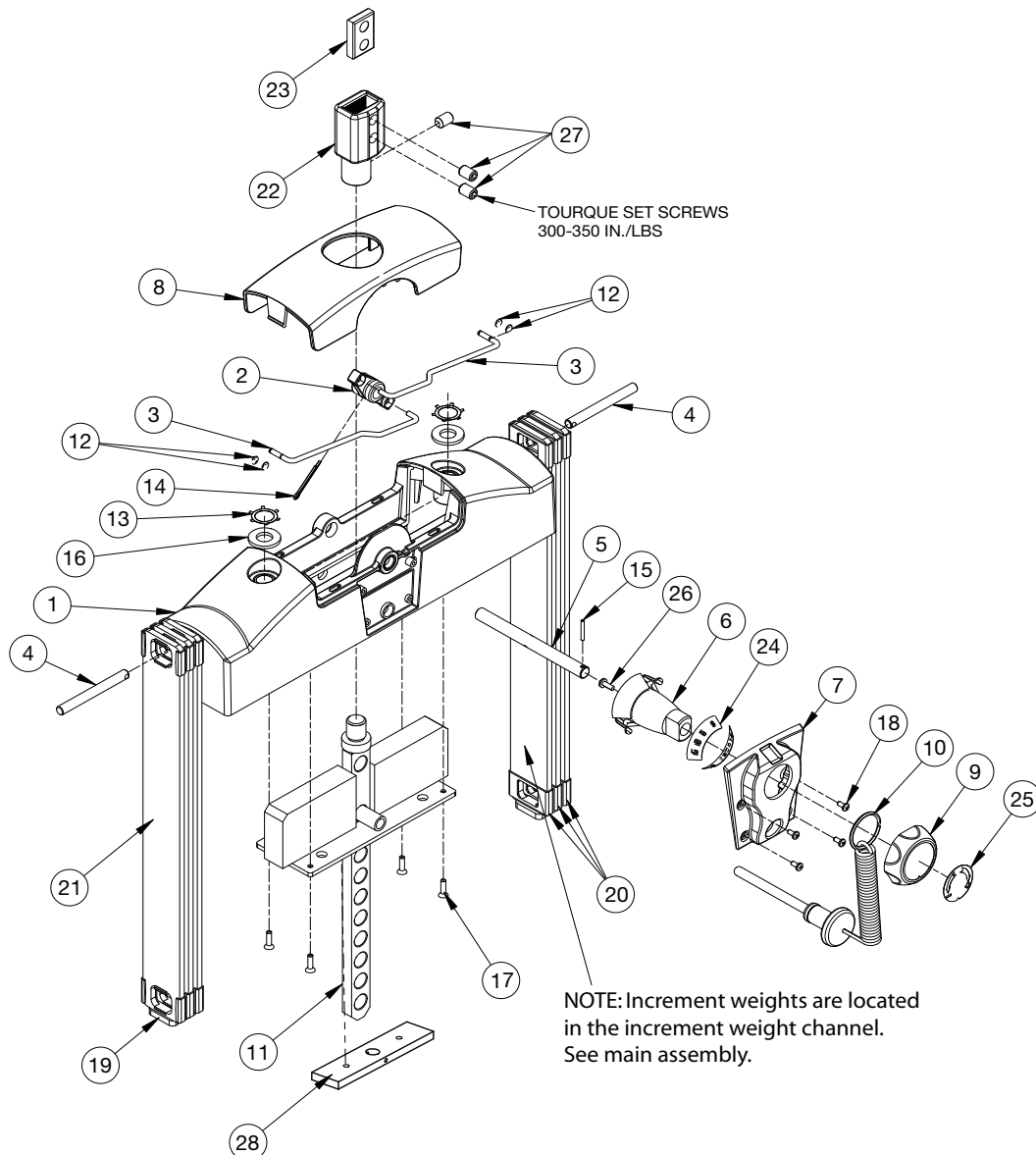

BELT ROUTING DETAIL

