

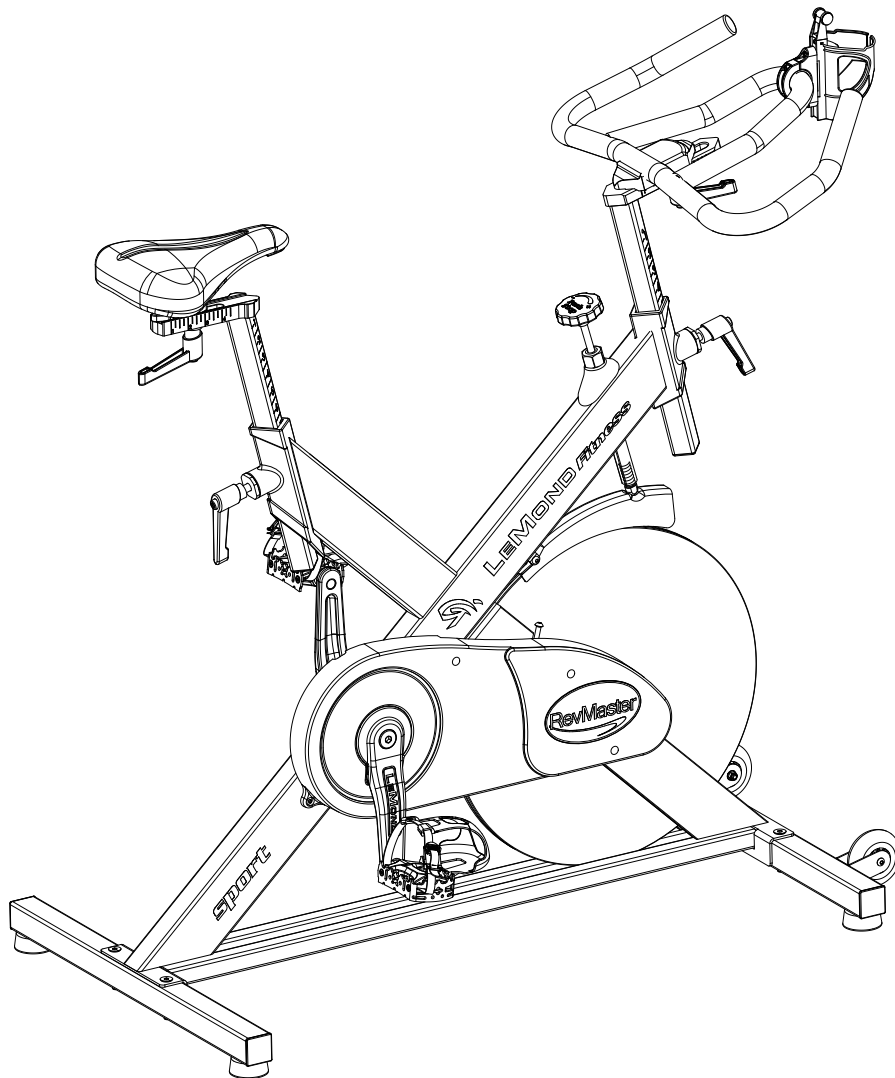

**LEMOND<sup>®</sup>**  
***Fitness Inc.***

# OWNER'S MANUAL



**LEMOND<sup>®</sup>**  
***RevMaster™***

***sport***

## LeMond<sup>®</sup> RevMaster Sport<sup>™</sup>

*Visit our website at*  
[www.Lemondfitness.com](http://www.Lemondfitness.com)



LeMond Fitness Inc.  
15540 Woodinville-Redmond Road NE  
Suite A100  
Woodinville, WA 98072 USA  
Telephone (+1) 425.482.6773  
Fax: (+1) 425.482.6724

© 2008 LeMond Fitness Inc. LeMond and RevMaster are registered trademarks.

## CONGRATULATIONS

You have just become a valued LeMond fitness customer. Our team is committed to making your cycling experience fun and rewarding — offering you detailed product information, expert fitness advice, and direct customer support you can depend on. I want to thank-you for purchasing an exciting LeMond **RevMaster Sport** indoor group cycle.

This **RevMaster Sport** Owner's Manual will help you get the most enjoyment from your new indoor group cycle. It not only explains all the important features and safety considerations of the **RevMaster Sport**, it also includes great workout tips and exercise principles. If at any time you have questions about this information, please call us at (425) 482-6773 and we will be happy to help you. To help us answer your questions quickly, we recommend that you have the serial number of your bike ready when you call us. The serial number of your bike is located on the back side of the belt cover.

The **RevMaster Sport** has been tested by some of America's most famous cyclists. Our company founder, Greg LeMond, is the force behind the inspiration and design of this remarkable indoor bike. Greg's story is one of courage and heroic accomplishment. In 1986, Greg became the first American to win the longest and most physically demanding event in the world — the Tour de France. Only nine months later in April of 1987, he narrowly escaped death when he was accidentally shot in a hunting accident. During a long and painful rehabilitation, he set a goal that many considered inconceivable: to once again win the Tour de France. In 1989, he achieved that goal, and then proved it was no mere stroke of luck by winning the Tour a third time in 1990.

A legendary athlete, Greg introduced many cycling innovations during his racing career. Just as aero bars are now commonplace, the **RevMaster Sport** is the new standard in indoor group cycles. The **RevMaster Sport** combines Greg's passion for cycling with exceptional product innovation. Built to deliver an incredible workout, every component of the **RevMaster Sport** has been designed to be more innovative, more user friendly and more comfortable than any other indoor group cycle you have ridden. Whether you are a beginning fitness enthusiast or a highly conditioned athlete, you will immediately feel the difference.

### Greater Comfort

- 4-way handlebar & seat adjustability allows you to properly fit your bike ranging from the upright position to a low, stretched out setup ideal for triathletes.
- Narrower crank design replicates the geometry of a road bike for greater comfort.
- Interchangeable seat options allow you to tailor the seat to your personal preference.

Finally, its attractiveness and small footprint allows you to position the **RevMaster Sport** in any location for maximum enjoyment; and you'll also enjoy how quiet a **RevMaster Sport** workout is. All together, you will quickly discover that the **RevMaster Sport** gives you a better cycling experience than any other indoor group cycle.





## FEATURES

- Excellent stability, and 300 lb. user load
- New bottom bracket cartridge — Fast, simple assembly and service
- New fender with integrated brake assembly — Keeps sweat off the flywheel and is easy to remove for service
- Standard pedal thread — Accepts most standard cycling pedals
- Faster assembly — Most components are pre-assembled
- No calibration required — Just hop on & ride

## Exclusive Features

- 4-way micro adjustability for both seat & handlebars put you in the “sweet zone” for muscular participation; allowing you to involve more muscles for better workouts.
- The **RevMaster Sport** is so smooth and comfortable you can work out much longer than you ever imagined.

Please review the rest of this Owner’s Manual carefully before you start using your new **RevMaster Sport**. The information enclosed here will help you get the most enjoyment out of your workout and includes valuable operating, service, safety, and trouble-shooting information, as well as guidelines for an effective exercise program.

We are confident that you will love your new **RevMaster Sport**. From Greg and the whole LeMond Fitness team, we wish you a lifetime of good rides and great workouts.

WARRANTY ..... 6

SAFETY GUIDELINES ..... 7

ASSEMBLY AND INSTALLATION INSTRUCTIONS ..... 9

GUIDELINES FOR SAFE OPERATION ..... 13

OPERATING INSTRUCTIONS ..... 14

GENERAL EXERCISE GUIDELINES ..... 16

MAINTENANCE INSTRUCTIONS ..... 18

TROUBLESHOOTING ..... 20

SPECIFICATIONS ..... 22

EXERCISE LOGS ..... 24



**WARRANTY**

This is to certify that the LeMond® RevMaster Sport™ exercise bike is warranted by LeMond Fitness Inc. to be free of all defects in materials and workmanship. This warranty does not apply to any defect caused by negligence, misuse, accident, alteration, improper maintenance, or an “act of God.”

The LeMond RevMaster Sport Product Warranty assumes that the recommended service guidelines have been followed by the customer, and covers the following:

**Parts:**

- Frame - 5 years
- Cranks, flywheel, handlebar, handlebar post, seat post - 3 years
- Bottom bracket cartridge assembly, pillow block bearings, tension assembly -1 year
- Pedals - 90 days
- Seat, grip, handles, pedal straps, and brake pad - 90 days

Contact our Customer Service Department to report any problems. When calling, please be prepared to provide the customer service representative with the following information:

- Your name, customer number, shipping address, and telephone number
- The serial number(s) of the inoperable bike(s)
- The date(s) of purchase for the inoperable bike(s)
- Your billing address

This information will ensure that you are the only one ordering parts under your warranty protection. If warranty replacement parts are shipped to you, you may be required to return the inoperable part. To facilitate this process, the following policy has been established:

- Please call our Customer Service Department (425.452.6773) to receive a return goods authorization prior to shipment.
- LeMond Fitness will incur all ground freight charges for warranty parts ordered for a machine that is less than 90 days old.
- You are responsible for freight charges on warranty parts for machines that are more than 90 days old. (You will not be responsible for the freight charges for any returned inoperable parts.)
- If an inoperable warranty parts must be returned to our Customer Service Department, we will pay the shipping cost and provide detailed return shipping instructions. These instructions will be sent along with your warranty replacement part.

LeMond Fitness Inc. neither makes, assumes nor authorizes any representative or other person to make or assume for us, any other warranty whatsoever, whether expressed or implied, in connection with the sale, service, or shipment of our products. We reserve the right to make changes and improvements in our products without incurring any obligation to similarly alter products previously purchased. In order to maintain your product warranty and to ensure the safe and efficient operation of your machine, only authorized replacement parts can be used. This warranty is void if parts other than those provided by LeMond Fitness are used.

## IMPORTANT SAFETY INSTRUCTIONS



This symbol appearing throughout this manual means:

**Attention! Be Alert! Your safety is involved.**

The following definition applies to the word "WARNING" found throughout this manual:

### **WARNING**

Used to call attention to POTENTIAL hazards that could result in personal injury or loss of life.

READ ALL INSTRUCTIONS BEFORE USING THIS EXERCISE EQUIPMENT.

1. The RevMaster Sport indoor group cycle is intended for cardiovascular fitness training and may be used in group or individual settings. Use this equipment only for its intended use as described in this manual. Do not attempt to ride this bike at high pedal speeds or in a standing position until you have practiced and are comfortable riding at slower pedal speeds.
2. This unit is NOT equipped with a freewheel system. If the flywheel is in motion, the pedals will be in motion. Do not attempt to stop the unit by applying reverse pressure to the pedals as knee injury may occur. Do not attempt to remove your feet from the pedals while they are in motion as serious injury may occur from the spinning pedals.
3. Wait for the flywheel to coast to a stop. If you want to quickly stop the flywheel, apply firm downward pressure to the brake knob. Do not attempt to dismount the RevMaster Sport unless the pedals and the flywheel are at a complete stop.
4. Injury or death may occur from improper use or over-training. Consult a medical doctor or qualified fitness instructor to determine an exercise program appropriate to your level of fitness.
5. Never attempt to turn the pedal crank arms by hand. Do not expose your hands or your arms to the drive mechanism as possible injury could occur.
6. In commercial settings, the RevMaster Sport should always be used in a supervised environment with qualified instructors.
7. In a home setting, keep unsupervised children away from the unit when not in use. Keep children and pets away from the unit while in use.
8. Do not perform push-up type movements on the handlebars.
9. Never drop or insert any object into any opening on the exercise equipment.
10. Only use the unit on a stable, level floor.

11. Follow the instructions for safe use of the equipment including proper seat position, handlebar position, and use of the foot positioning system of the pedals. Never adjust the handlebars past the minimum safe insertion depth marked with the word "MAX".
12. For safe operation, allow for at least 1 foot (30cm) of free space to either side of the unit and 2 feet (60cm) of free space to the rear of the unit.

The safety level given by the design of this equipment can only be maintained when the equipment is regularly examined for damage and wear. Inoperable components should be replaced immediately or the equipment should not be used until it is repaired.

Failure to follow all guidelines may compromise the effectiveness of the exercise experience, expose yourself (and possibly others) to injury, and reduce the longevity of the equipment.

## SAVE THESE INSTRUCTIONS

Your Serial Number:

---

Your LeMond Fitness:

Dealer: \_\_\_\_\_

Phone: \_\_\_\_\_

Your comments and suggestions are welcome.  
Congratulations, and thank you for buying the RevMaster Sport.

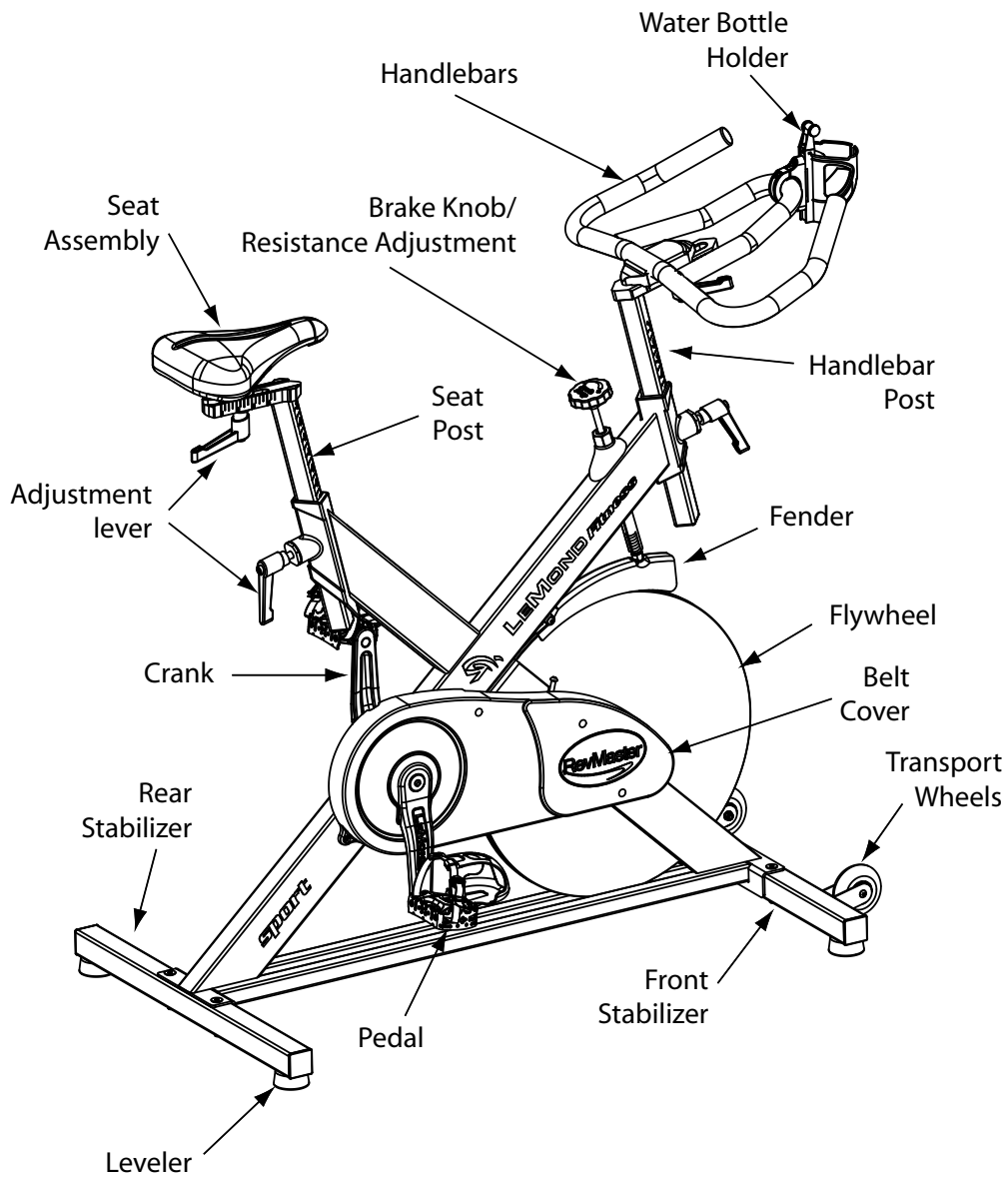

LeMond RevMaster Sport

**ASSEMBLY AND INSTALLATION**

Before leaving the manufacturing facility, your LeMond® RevMaster Sport® exercise bike was thoroughly inspected and tested for proper operation. To minimize shipping damage, careful attention was given to making your bike ready for shipment.

**DELIVERY**

Your LeMond RevMaster Sport will arrive packed in 1 carton. Upon arrival fully inspect the carton for damage. Point out any damage to the delivery person and have the delivery person record the damage on the delivery paperwork. Contact the Customer Service Department at (425) 482-6773 to report any damage.

Please follow these detailed instructions and you will find that your bike can be unpacked and assembled with ease.

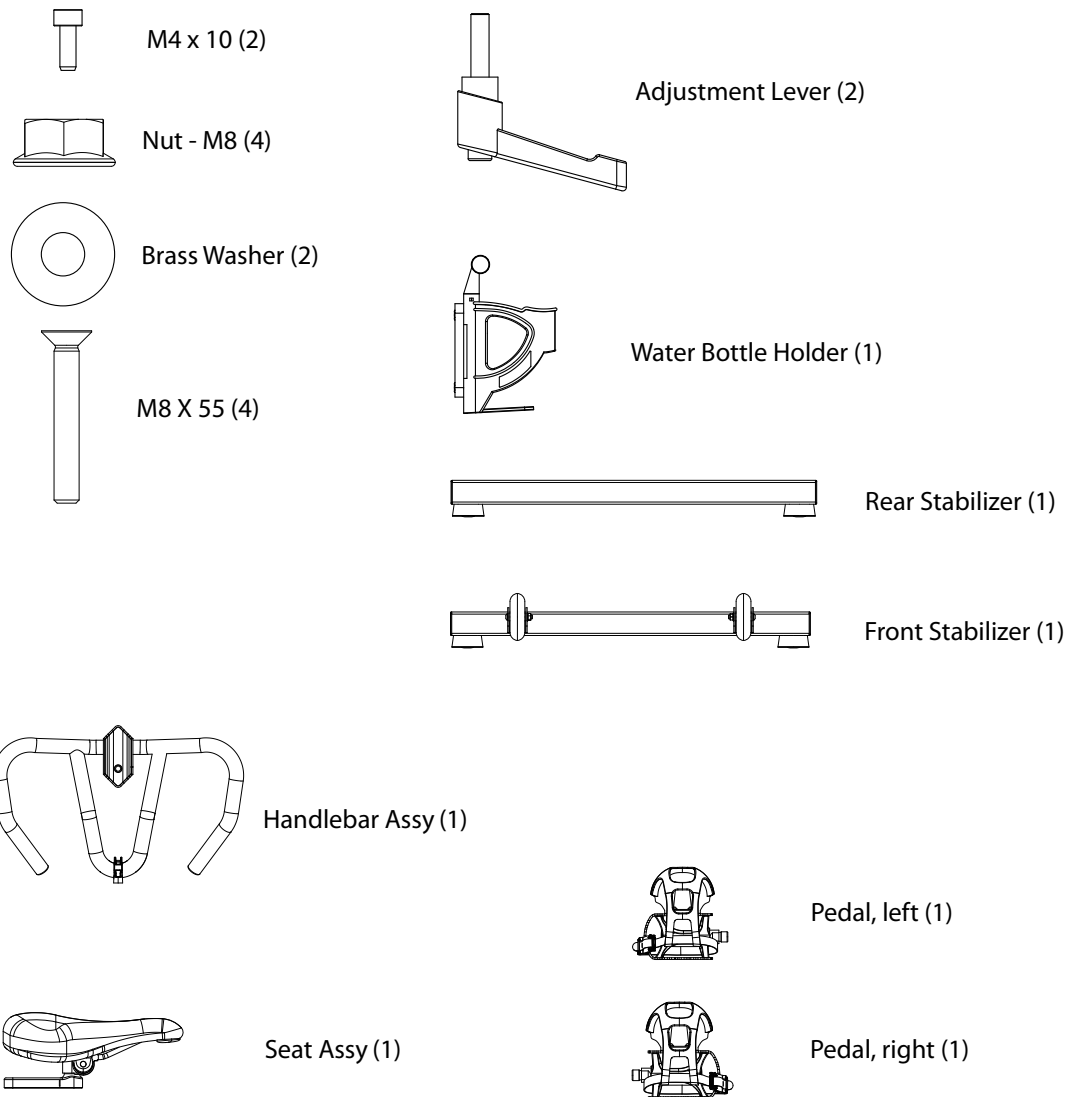

*[not to scale]*

Assembly Parts

**REMOVE THE BIKE AND COMPONENTS FROM THE SHIPPING CARTON**

1. Move the box to the desired location. Ensure that the carton is standing upright and remove the strapping material.
2. Pull the cardboard edge out along the bottom of the box to remove the staples. Lift the top of the box up and set aside.
3. Remove the two smaller boxes from the main frame of the bike.
4. Open both boxes and verify that you have all of the hardware and parts necessary to assemble your bike; you should have this owner's manual, all the illustrated assembly parts, and all the necessary tools.

**ASSEMBLY**

*Note: It is not necessary to remove the bike from the foam shipping cradle before assembly.*

1. Align the front stabilizer (the one with the transport wheels) with the holes in the main frame, below the flywheel.
2. Attach the stabilizer with two (2) M8 x 55 mm screws and two (2) M8 nuts. Tighten them with a hex key

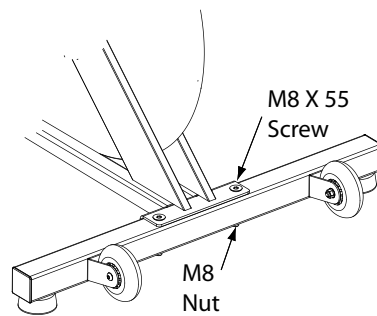

3. Align the rear stabilizer with the holes in the main frame below the seat post
4. Attach the rear stabilizer with two (2) M8x55 mm screws and two (2) M8 nuts. Tighten them with a hex key.

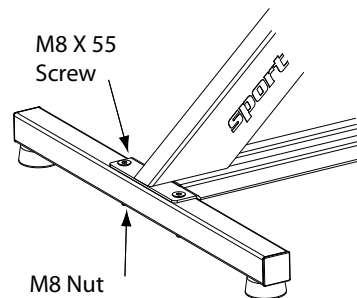



5. Position the seat assembly atop the seat track on the seat post. Lightly grease the end of the threads on an adjustment lever. Loosely thread the adjustment lever through the brass washer, through the hole in the seat track, and into the seat assembly. Slide the seat to the desired position and tighten the adjustment lever.

**Note:** The handle on the adjustment lever has a ratchet function. Once you have tightened a lever, pull out on the handle and rotate it so it does not stick out. Release the handle to lock it into place.

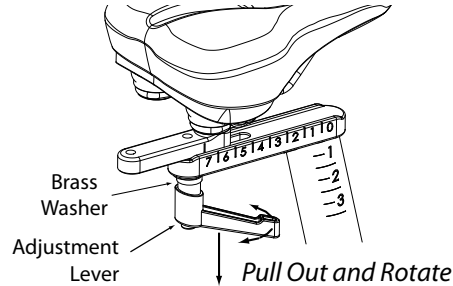

6. Position the handlebar on top the handlebar track. Lightly grease the end of the threads on an adjustment lever. Loosely thread the adjustment lever through the brass washer and into the hole in the handlebar. Slide the handlebar to the desired position and tighten the adjustment lever. (Use the adjustment lever's ratchet function as necessary.)

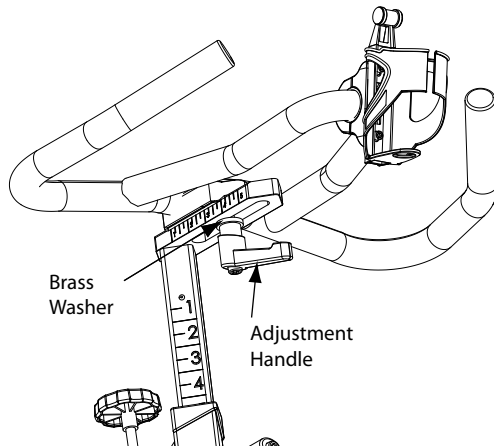

**Note:** The brass washer must be installed so the handlebar can be adequately tightened before use.

7. The pedals are marked as if you are seated on the bike, "R" for right, and "L" for left. **Note:** The left pedal is reverse-threaded. Carefully thread the right pedal into the crank arm with your fingers - do not cross thread the pedal in the crank arm! Use the included multi-tool or a 15 mm pedal wrench tool to tighten the pedals. Repeat this step for the left pedal.
8. To install the bottle holder, align the bottle holder mounting bracket on the handlebar and attach with two (2) M 4 X 10 mm screws. Tighten with a hex key.

**GUIDELINES FOR SAFE OPERATION**



**WARNING**

THESE GUIDELINES ARE DIRECTED TO YOU, AS THE OWNER OF THIS EXERCISE EQUIPMENT. YOU SHOULD INSIST THAT ALL USERS FOLLOW THE SAME GUIDELINES. YOU SHOULD MAKE THIS MANUAL AVAILABLE TO ALL USERS.

1. Obtain a complete physical examination from your medical doctor and enlist a health/fitness professional's aid in developing an exercise program suitable for your current health status.
2. When working out for the first time, start out slowly for a minimum of five minutes. After your muscles are warmed up, gradually increase the pedaling rate and/or resistance to a speed that allows you to attain your target heart rate zone.
3. The speed and duration of your exercise program should always be subject to how you feel. Never permit peer pressure to exceed your personal judgment while exercising.
4. Overweight or severely deconditioned individuals should be particularly cautious when using the equipment for the first time. Even though such individuals may not have histories of serious physical problems, they may perceive the exercise to be far less intense than it really is, resulting in the possibility of overexertion or injury.
5. Although all equipment manufactured by LeMond® Fitness, Inc. has been thoroughly inspected by the manufacturing facility prior to shipment, proper installation and regular maintenance are required to ensure safety. Maintenance is the sole responsibility of the owner.



## INSTRUCTIONS FOR FIRST-TIME USERS

Your First Workout On The LeMond® RevMaster Sport™

### ADJUSTING THE FIT

Take a moment to learn how to properly fit your RevMaster Sport to your body; it will make your workouts a more pleasant and safer experience. The RevMaster Sport provides more seat and handlebar adjustability than any other indoor group cycle, and each adjustment is numbered so you can quickly return the adjustments to your specific settings. Making full use of these features will give you the most comfortable ride possible and allow you to exercise efficiently. Using the bike when it is incorrectly adjusted can result in unnecessary discomfort and increase your risk of injury.

#### Seat Adjustment:

##### Adjusting the Seat's Height

1. Stand next to the seat post and adjust the seat to hip height.
2. Rotate the crank so that the pedals are in the vertical, 12 and 6 o'clock, position.
3. Place your foot in the toe cage of the pedal closest to the floor and mount the bike. Ensure that the ball of your foot is over the center of the pedal. Your leg should be slightly bent at the knee (155° extension), as shown in the picture to the right.
4. If your leg is too straight or your foot cannot touch the pedal you will need to lower the seat. If your leg is bent too much you will need to raise the seat.
5. Dismount the bike and loosen the seat post adjustment handle. Once loosened, slide the seat post up or down as necessary.
6. When the seat is in the desired position, tighten the adjustment handle to secure the seat post.
7. Note the final position mark on the seat post for future reference.

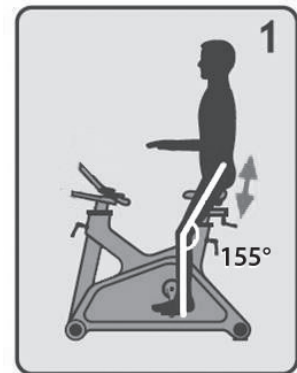

##### Adjusting the Seat's Forward/Aft Position

8. Sit on your bike with the cranks in the 3 and 9 o'clock positions. A proper forward/aft position of the seat is achieved when the small bump at the top of the shin of your forward leg, directly below the knee cap (tibial tuberosity), is above the pedal axle.
9. Dismount to adjust the seat forward or aft for a better fit. Loosen the seat adjustment lever and slide the seat forward or backward as desired; then tighten.
10. Note the final position mark under the seat for future reference. (Repeat steps 2 through 7 if necessary.)

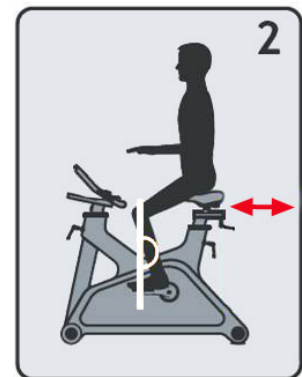

**Note:** There are two threaded holes on the seat assembly slider, to allow a greater range of forward/aft ad-

*justment. The seat adjustment lever can be attached to either. Taller users may want to use the front hole; shorter users may want to use the back hole.*

### Handlebar Adjustment:

#### Adjusting the Handlebar Height

1. Handlebar height is a matter of preference. Start with the handle bars at the same height as the seat. Adjusting the handlebars higher will give the rider a more upright position; lowering them will result in a more prone position.
2. Raise or lower the handlebars by loosen the handlebar post adjustment and sliding the handlebar post up or down as desired. Tighten the adjustment handle to secure the handlebar post. Note the final position mark on the handlebar post for future reference.



#### Adjusting the Handlebar's Forward/Aft Position

3. Loosen the handlebar forward/aft adjustment lever and slide the handlebars either forward or backward as desired. The forward/aft position should be set to allow the rider to comfortably grasp the handles with a slight bend at the elbow.
4. Tighten the adjustment lever clockwise to secure the handlebar assembly. (Remember to use the ratchet feature of the adjustment lever as necessary.) Note the final position mark for future reference.

**BASIC OPERATION**

Now that you have established a riding position, take a few minutes to ride the bike and determine that your position is comfortable. Start pedaling at a slow pace with your toes and knees pointed directly forward. Hold the grips lightly and in a position that allows your shoulders and upper body to relax. Pedal easily, at a low resistance, until you feel confident that you could ride in that position for the duration of your workout.

**WARNING**

IF AT ANY TIME DURING YOUR WORKOUT, YOU FEEL CHEST PAIN, EXPERIENCE SEVER MUSCULAR DISCOMFORT, FEEL FAINT, OR ARE SHORT OF BREATH, STOP EXERCISING IMMEDIATELY. IF THE CONDITION PERSISTS, YOU SHOULD CONSULT YOUR MEDICAL DOCTOR IMMEDIATELY.

1. Pedaling resistance is controlled by the tension knob located beneath the handlebar, on the main "X" part of the frame. Resistance may be changed at any time by turning the tension knob; clockwise for more resistance, or counterclockwise for less resistance.
2. To apply the brake, press down on the tension knob.
3. Before dismounting, apply the break to stop the flywheel, or increase the resistance and let the flywheel come to a stop.
4. To dismount the bike, first loosen each toe cage strap and remove your feet from the pedals, then step off the bike.

**GENERAL EXERCISE GUIDELINES****SETTING A GOAL**

The first step to a successful exercise program is to set realistic goals and objectives. Do you want an exercise program that is geared to build muscle, maintain muscle tone, increase aerobic capacity, or lose weight? In order to ensure that you fully receive all the benefits of a sound exercise program, you need to first identify the existence (if any) of risk factors that may influence the design of your exercise program. Based upon a comprehensive analysis of your personal exercise needs and interests, you should then develop (or have developed for you by a competent or trained professional) an individualized program of exercise that is enjoyable, easy, and yet challenging. Your greatest health benefit will come from a lifestyle change that encourages a lifetime of physical activity.

One way to guarantee success in reaching your goal is to eat correctly. A well-rounded diet provides the proteins, carbohydrates, fats, vitamins, minerals, and water necessary for good health. If you are unsure of your dietary needs, seek the advise of your physician, an exercise professional, or visit your local bookstore for more information on nutrition.

**FLEXIBILITY TRAINING\***

Achieving and maintaining an adequate range of motion should always be objectives of a comprehensive exercise program. The warm-up phase of your exercise session should include some type of light warm-up activity to increase both your heart rate and your body temperature, which is then followed by flexibility exercises that are specifically designed to stretch the musculature around your body's major skeletal joints. Attempting to stretch a cold muscle can be dangerous to the soft tissues surrounding the muscle. No matter how controlled the movement, forcing a muscle through a full range of motion (and beyond) without appropriately warming up is both unsafe and counterproductive.

A general exercise program for achieving and maintaining flexibility should adhere to the following guidelines:

- Frequency                      Daily
- Intensity                        To a position of mild discomfort
- Duration                        10-30 seconds for each stretch
- Repetitions                    2-6 for each stretch
- Type                              Static, with a major emphasis on the low back and hamstrings area because of the high prevalence of low-back pain syndrome in our society.

**EXERCISE PRINCIPLES \***

The American College of Sports Medicine has developed a position paper concerning exercise programs for healthy adults and the need for guidelines. The following recommendations concern the quantity and quality of (exercise) training for developing and maintaining cardiorespiratory fitness in a healthy adult:

- Frequency                      3 to 5 days per week
- Intensity                        50% - 85% of maximum oxygen uptake (VO<sub>2</sub> max)
- Duration                        20 to 60 minutes of continuous aerobic activity
- Mode of Activity              Any activity that uses the large muscle groups, that can be maintained continuously, and is rhythmical and aerobic in nature.
- Rate of Progression        Initial Conditioning: - 4 to 6 weeks; low end intensity (40% - 60% VO<sub>2</sub> max); low end duration (15 to 20 minutes).  
Improvement Stage: - 6 weeks to 6 months; moderate intensity; moderate duration.  
Maintenance Stage: - 6 months plus; moderate to high intensity; moderate to high duration.

*\*Note: Some of the material contained in this section is adapted from The StairMaster® Fitness Handbook 2nd Ed., James A Peterson, and Cedric X. Bryant (editors), Sagamore Publishing, 1995.*

## **MAINTENANCE INSTRUCTIONS**

### **HELPFUL HINTS**

The safety level given by the design of this equipment can only be maintained when the equipment is regularly examined for damage and wear. Inoperable components should be replaced immediately or the equipment should be put out of use until it is repaired. Read all maintenance instructions thoroughly before beginning work.

All references to the right or left side and to the front or back are made as if you were on the exercise equipment ready to exercise. For example, the belt is on the right side of the bike.

### **TOOL LIST**

The following tools are needed to perform service and maintenance:

- 15mm Pedal Wrench or Open End Wrench
- Metric Hex Key Set (up to 8mm)
- #2 Phillips Screwdriver
- Bottom Bracket Tool (Park BBT-2 or comparable 20-Tooth Tool)
- Crank Puller (Park CCP-2 or comparable Puller for Square, Tapered Spindles)
- Loctite 242 Medium Strength threadlocker
- Brake Pad Oil or 3-In-One Oil

### **INITIAL SERVICE**

Upon receiving your equipment, use a soft clean cloth to wipe off the dust that may have accumulated during shipping. Your equipment will need minor assembly. Refer to the "Assembly Instructions" section of this manual for details.

MAINTENANCE SCHEDULE

PART	RECOMMENDED ACTION	FREQUENCY	CLEANER	LUBRICANT
<sup>1</sup> Pedals	Ensure that the pedals are tight in crank arms; that all screws on pedals are tight; and that the pedal straps are not frayed	Before each use	N/A	N/A
Frame	Wipe down	Daily	Soap & water; or, diluted non-abrasive cleaning solution	N/A
Flywheel	Wipe down	Weekly	WD-40® spray. Spray on rag & apply light coat to sides of flywheel.	N/A
Crank Bolts	Inspect for looseness	Weekly	N/A	If loose, tighten to 48 ft-lbs or 575 in-lbs
Brake Pad	Inspect for excessive wear or a dry leather brake pad	Weekly	N/A	<sup>2</sup> Use 3-IN-One® oil or 10W oil *Do not use silicone-based lubricants
Belt	Inspect for correct tension; replace cracked, frayed, or otherwise non-uniform belt	Monthly	N/A	N/A
Bottom Bracket	Inspect for side-to-side play in spindle, and a grinding feeling in crank area when pedaling. If necessary, replace bottom bracket.	Monthly	N/A	N/A

1. We do not recommend you attempt to service the internal parts of the pedals. If they are found to be worn internally, we recommend replacing the pedal.

2. Use of lubricants or cleaning solutions other than those so specified will result in diminished performance and a shorter life span for that part.



## TROUBLESHOOTING

### **SYMPTOM: Clicking noise with each pedal revolution.**

1. Check shoelaces to make sure the aglet is not tapping the bike as the pedals turn.
2. Assure pedal straps are tight and that no excess strap on inner part of pedal is catching on the crank arm as it turns.
3. Assure that pedals are tight on crank arms.

### **SYMPTOM: Clicking noise when flywheel rotates.**

1. Check edge of flywheel that brake pad rubs against for small burrs.
2. If burr is present gently remove while being careful not to damage flywheel surface.
3. If symptom persists check for noisy flywheel bearings.
4. If flywheel bearings are noisy or rough have authorized service technician replace flywheel hub assembly.

### **SYMPTOM: Drive belt is slipping.**

1. Remove belt cover.  
**Note:** Use caution around belt when cover is removed.
2. Loosen idler with adjustable wrench and tighten tensioner bolt 2-3 turns with 5mm hex wrench.
3. Tighten idler and test belt.
4. If belt still slips repeat process until belt no longer slips.
5. Reinstall belt cover.

### **SYMPTOM: Knocking noise or play felt in pedals/cranks.**

1. Make sure pedals are tight on crank arms.  
**Note:** Left pedal is reverse threaded.
2. Make sure crank bolts are tight. If loose, tighten crank bolts to 48 ft-lbs (575 in-lbs) with 8mm hex wrench.
3. If problem persists check the bottom bracket bearing cups for looseness. Tighten if necessary with a bottom bracket tool and use blue Loctite 242 on threads.
4. If knocking noise still persists contact authorized service technician for replacement of bottom bracket bearings.

### **SYMPTOM: Inconsistent resistance or noisy brake pad.**

1. Remove fender assembly and make sure brake pad is clean.
2. Apply brake pad oil (or 3-In-One oil) to surface of brake pad.
3. Let oil soak into pad and reapply if needed until brake pad is thoroughly saturated.
4. Reinstall fender assembly.

**SYMPTOM: Rocking or movement from RevMaster Sport while in use.**

1. Using a 5mm hex wrench, check the attachment bolts on the front and rear stabilizers and make sure they are tight.
2. Assure the bike is level by checking the leveling feet on the bottom of the front and rear stabilizers.



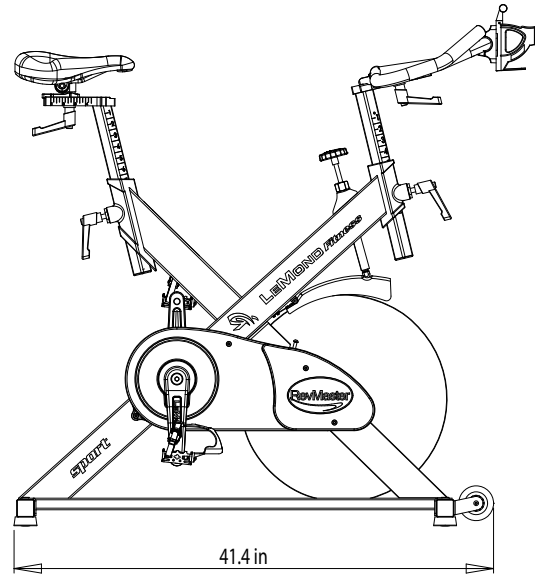
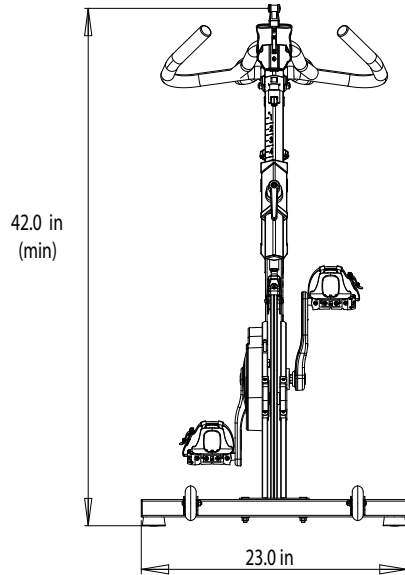

**PHYSICAL DIMENSIONS:**

**Length:** 41.4 in (105 cm)

**Weight:** 42 in (106.7 cm)

**Width:** 23 in (58.4 cm)

**Weight:** 114 lbs (51.7 kg)

**Shipping Carton Dimensions:**

**Length:** 40 in (101.6 cm)

**Height:** 33 in (83.8 cm)

**Width:** 8 in (20.3 cm)

**Weight:** 133lbs (60.3 kg)

**FRAME:**

- Welded X Style frame
- ED and powder coated finish
- 22 inch wide base with large diameter adjustable levelers

**FLYWHEEL:**

- Precision-machined flywheel
- Forged steel axle with Electroless-Nickel finish

**BRAKING AND RESISTANCE MECHANISM:**

- Turn-knob design for tension; push down for braking
- Leather resistance pad on top of flywheel for consistent resistance

**CRANK SET:**

- Forged cranks (170 mm)
- Oversized and hardened Cr-Moly bracket spindle (23.0 mm x 124.5 mm)
- Two piece cartridge style ball bearing assy. with 2 bearing per side

**HANDLEBARS:**

- Biomechanically correct with anatomical bend
- Up/down and fore/aft adjustability with position indicator marks
- Durable, dip-coated handlebar

**SEAT:**

- Up/down and fore/aft adjustability with position indicator marks
- Dual position seat slider for extended fore/aft adjustment
- Adjustment marks for up/down and fore/aft

**TRANSPORT WHEELS**

- Extra large in-line skate wheels

**DRIVE TRAIN**

- Reinforced Poly-V drive belt
- Precision drive pulleys
- No belt tension adjustments required



# Daily and Monthly Exercise Logs

Week #		Weekly Goals			
		1.			
		2.			
		3.			
Day	Date	Distance	Calories	Time	Comments
Mon					
Tue					
Wed					
Thu					
Fri					
Sat					
Sun					
Weekly Totals					

Week #		Weekly Goals			
		1.			
		2.			
		3.			
Day	Date	Distance	Calories	Time	Comments
Mon					
Tue					
Wed					
Thu					
Fri					
Sat					
Sun					
Weekly Totals					

Week #		Weekly Goals			
		1.			
		2.			
		3.			
Day	Date	Distance	Calories	Time	Comments
Mon					
Tue					
Wed					
Thu					
Fri					
Sat					
Sun					
Weekly Totals					

Week #		Weekly Goals			
		1.			
		2.			
		3.			
Day	Date	Distance	Calories	Time	Comments
Mon					
Tue					
Wed					
Thu					
Fri					
Sat					
Sun					
Weekly Totals					

Week #		Weekly Goals			
		1.			
		2.			
		3.			
Day	Date	Distance	Calories	Time	Comments
Mon					
Tue					
Wed					
Thu					
Fri					
Sat					
Sun					
Weekly Totals					

Week #		Weekly Goals			
		1.			
		2.			
		3.			
Day	Date	Distance	Calories	Time	Comments
Mon					
Tue					
Wed					
Thu					
Fri					
Sat					
Sun					
Weekly Totals					

MONTH		Monthly Goals	
		1.	
		2.	
		3.	
Week	Distance	Calories	Time
Monthly Totals			

MONTH		Monthly Goals	
		1.	
		2.	
		3.	
Week	Distance	Calories	Time
Monthly Totals			

MONTH		Monthly Goals	
		1.	
		2.	
		3.	
Week	Distance	Calories	Time
Monthly Totals			

MONTH		Monthly Goals	
		1.	
		2.	
		3.	
Week	Distance	Calories	Time
Monthly Totals			

MONTH		Monthly Goals	
		1.	
		2.	
		3.	
Week	Distance	Calories	Time
Monthly Totals			

MONTH		Monthly Goals	
		1.	
		2.	
		3.	
Week	Distance	Calories	Time
Monthly Totals			



15540 Woodinville-Redmond Road NE

Suite A100

Woodinville, WA 98072 USA

[www.Lemondfitness.com](http://www.Lemondfitness.com)

Telephone (+1) 425.482.6773

Fax: (+1) 425.482.6724