

# ***93T Treadmill*** operation manual



*LifeFitness*

## **CORPORATE HEADQUARTERS**

10601 West Belmont Avenue  
Franklin Park, Illinois 60131 • U.S.A.  
847.288.3300 • FAX: 847.288.3703  
800.735.3867 (Toll-free within U.S.A., Canada)

## **INTERNATIONAL OFFICES**

### **LIFE FITNESS ASIA PACIFIC LTD**

Room 2610, Miramar Tower  
132 Nathan Road  
Tsimshatsui, Kowloon  
HONG KONG  
Telephone: (+852) 2891.6677  
FAX: (+852) 2575.6001

### **LIFE FITNESS ATLANTIC BV**

#### **LIFE FITNESS BENELUX**

Bijdorpplein 25-31  
2992 LB Barendrecht  
THE NETHERLANDS  
Telephone: (+31) 180.646.666  
FAX: (+31) 180.646.699

### **LIFE FITNESS BENELUX NV**

Parc Industriel de Petit-Rechain  
4800 Verviers  
BELGIUM  
Telephone: (+32) 87.300.942  
FAX: (+32) 87.300.943

### **LIFE FITNESS DO BRAZIL**

Av. Dr. Dib Sauaia Neto 1478  
Alphaville, Barueri, SP  
06465-140  
BRAZIL  
Telephone (+55) 11.4193.8282  
FAX: (+55) 11.4193.8283

### **LIFE FITNESS AUSTRIA**

Vertriebs GmbH  
Hintschiggasse 1  
1100 Vienna  
AUSTRIA  
Telephone: (+43) 1.61 57 198  
FAX: (+43) 1.61 57 198.20

### **LIFE FITNESS IBERIA**

Pol. Ind. Molí dels Frares. c/C, nº 12  
08620 Sant Vicenç dels Horts (Barcelona)  
España  
Telephone: (+34) 93.672.4660  
FAX: (+34) 93.672.4670

### **LIFE FITNESS EUROPE GMBH**

Siemensstrasse 3  
85716 Unterschleissheim  
GERMANY  
Telephone: (+49) 89.31 77 51.0  
FAX: (+49) 89.31 77 51.99

### **LIFE FITNESS ITALIA S.R.L.**

Via San Pieretto  
37010 AFFI (Verona)  
ITALY  
Telephone: (+39) 045.7238204  
FAX: (+39) 045.7238197

### **LIFE FITNESS LATIN AMERICA and CARIBBEAN**

10601 West Belmont Avenue  
Franklin Park, Illinois 60131  
U.S.A.  
Telephone: (+1) 847.288.3300  
FAX: (+1) 847.288.3762

### **LIFE FITNESS UK LTD**

Queen Adelaide  
Ely, Cambs CB7 4UB  
UNITED KINGDOM  
Telephone: (+44) 1.353.666 017  
FAX: (+44) 1.353.666 018

### **LIFE FITNESS JAPAN**

Nippon Brunswick Bldg., #8F  
5-27-7 Sendagaya  
Shibuya-Ku, Tokyo  
Japan 151-0051  
Telephone: (+81) 3.3359.4309  
FAX: (+81) 3.3359.4307

M051-00K58-B081

06/03

Before using this product, it is essential to read this ENTIRE operation manual and ALL installation instructions.

It describes equipment setup and instructs members on how to use it correctly and safely.

Avant d'utiliser ce produit, il est indispensable de lire ce manuel d'utilisation dans son INTÉGRALITÉ, ainsi que TOUTES les instructions d'installations.

Ce manuel explique comment installer l'équipement et comment l'utiliser correctement et sans danger.

#### FCC Warning - Possible Radio / Television Interference

**NOTE:** *This equipment has been tested and found to comply with the limits for a Class A digital device, pursuant to part 15 of the FCC rules. These limits are designed to provide reasonable protection against harmful interference when the equipment is operated in a commercial environment. This equipment generates, uses and can radiate radio frequency energy, and if not installed and used in accordance with the instruction manual, may cause harmful interference to radio communications. Operation of this equipment in a residential area is likely to cause harmful interference in which case the user will be required to correct the interference at his own expense.*

Class SB (Studio): Professional and / or commercial use.



**CAUTION: Any changes or modifications to this equipment could void the product warranty.**

**Mise en garde : tout changement ou toute modification de ce matériel peut annuler la garantie du produit.**

Any service, other than cleaning or user maintenance, must be performed by an authorized service representative. There are no user serviceable parts.

# TABLE OF CONTENTS

Section	Description	Page
1.	Getting Started . . . . .	6
1.1	Important Safety Instructions . . . . .	6
1.2	Setup . . . . .	10
	Electrical Power Requirements	
	Grounding Instructions	
	Wax bag Instructions	
	How to Position and Stabilize the Treadmill	
	Power Switch	
	Setting the Clock	
	Centering the Belt	
	Fitness Networking	
	Power Cord Routing	
2.	The Display Console . . . . .	16
2.1	Display Console Overview . . . . .	16
2.2	Display Console Descriptions . . . . .	17
2.3	Reading Rack and Accessory Trays . . . . .	18
3.	Heart Rate Zone Training® Exercise . . . . .	19
3.1	Why Heart Rate Zone Training® Exercise . . . . .	19
3.2	Heart Rate Monitoring . . . . .	20
	The Optional Heart Rate Chest Strap	
4.	The Workouts . . . . .	21
4.1	Workout Overviews . . . . .	21
4.2	Using the Workouts . . . . .	21
4.3	Workout Descriptions . . . . .	22
	Quick Start	
	Manual	
	Hill	
	Random	
	Fit Test	
	Fat Burn	
	Cardio	
4.4	Maximizing Workouts on a Life Fitness Treadmill . . . . .	28
	Selecting an Intensity Level	
	Using InstaPace™ Feedback	
	Using ZerOut™ Speed Control	
	Cool-Down	
4.5	Logging On to the Network . . . . .	29
5.	The Manager's Configuration . . . . .	30
5.1	Entering and Using the Manager's Configuration . . . . .	30
5.2	Configuration Settings . . . . .	31
	Using the Start Message Setup	
	Using the MaxTime™ Setup	
	Using the Standby Setup	

6.	Service and Technical Data	.34
6.1	Preventive Maintenance Tips	.34
6.2	Preventive Maintenance Schedule	.35
6.3	Troubleshooting the Treadmill	.36
6.4	Troubleshooting the Optional Heart Rate Chest Strap	.39
6.5	How to Adjust and Tension the Striding Belt	.40
	The Belt Tensioning Bolts	
	Tracking (Centering) the Striding Belt	
	Tensioning an Existing Striding Belt	
6.6	Cleaning the Wax Nozzle	.42
6.7	How to Obtain Product Service	.43
7.	Specifications	.44
7.1	Life Fitness 93T Treadmill Specifications	.44

© 2003 Life Fitness, a division of Brunswick Corporation. All rights reserved. Life Fitness, Lifecycle, FlexDeck, and Heart Rate Zone Training are registered trademarks, and InstaPace, ZerOut, MaxTime, Intelli, MagnaDrive, Lifespring and "Rely on It" are trademarks of Brunswick Corporation. Polar is a registered trademark of Polar Electro, Inc. Cardio Theater is a registered trademark of Cardio Theater Holdings and a wholly owned subsidiary of ClubCom corporation. Broadcast Vision is a trademark of Broadcast Vision, Inc. Fitlinxx is a registered trademark of the Integrated Fitness Corp. Any use of these trademarks, without the express written consent of Life Fitness or the corresponding companies is forbidden.

This Operation Manual describes the functions of the following products:

Life Fitness Treadmill:

**93T**

See "Specifications" in this manual for product specific features.

Life Fitness **STRONGLY** recommends seeing a physician for a complete medical exam before undertaking an exercise program, particularly if the user has a family history of high blood pressure or heart disease, or is over the age of 45, or smokes, has high cholesterol, is obese, or has not exercised regularly in the past year.

If, at any time while exercising, the user experiences faintness, dizziness, pain, or shortness of breath, he or she must stop immediately.

Life Fitness recommande **FORTEMENT** de consulter un médecin pour subir un examen médical complet avant de commencer tout programme d'exercice, et tout particulièrement si l'utilisateur a des antécédents familiaux d'hypertension ou de troubles cardiaques, s'il a plus de 45 ans, s'il fume, s'il a du cholestérol, s'il est obèse ou n'a pas fait d'exercice régulièrement depuis un an.

Si, pendant l'utilisation de l'appareil, l'utilisateur ressent un malaise, des vertiges, des douleurs ou des difficultés à respirer, il doit s'arrêter immédiatement.

# 1 GETTING STARTED

## 1.1 IMPORTANT SAFETY INSTRUCTIONS

Read all instructions before using the treadmill.

- **DANGER:** To reduce the risk of electrical shock, always unplug this Life Fitness product before cleaning or attempting any maintenance activity.
- **WARNING:** To reduce the risk of burns, fire, electric shock, or injury, it is imperative to connect each product to a properly grounded electrical outlet.
- **WARNING:** Keep the area six feet (two meters) by three feet (one meter) behind the treadmill clear of any obstructions, including walls, furniture, and other equipment.
- **WARNING:** Be sure the emergency stop lanyard is clipped to the user and in proper position on the treadmill before beginning any workout.
- To disconnect, turn power OFF at the ON/OFF switch, then remove plug from electrical outlet.
- Never operate a Life Fitness product if it has a damaged power cord or electrical plug, or if it has been dropped, damaged, or even partially immersed in water. Contact Life Fitness Customer Support Services.
- Position this product so that the power cord plug is accessible to the user.
- Keep the power cord away from heated surfaces. Do not pull the equipment by the power cord or use the cord as a handle. Do not run the power cord on the floor under or along the side of the treadmill. Refer to Section 1.2 for proper power cord routing.
- If the electrical supply cord is damaged, it must be replaced by the manufacturer, an authorized service agent, or a similarly qualified person to avoid a hazard.
- Do not use this product in areas where aerosol spray products are being used or where oxygen is being administered. Such substances create the danger of combustion and explosion.
- Always follow the console instructions for proper operation.
- Close supervision is necessary when used near children, invalids or disabled persons.
- Do not use this product outdoors, near swimming pools or in areas of high humidity.
- Never operate a Life Fitness product with the air openings blocked. Keep air openings free of lint, hair, or any obstructing material.
- Never insert objects into any opening in this product. If an object should drop inside, turn off the power, unplug the power cord from the outlet, and carefully retrieve it. If the item cannot be reached, contact Life Fitness Customer Support Services.

- Never place liquids of any type directly on the unit, except in an accessory tray or holder. Containers with lids are recommended.
- Do not use this product in bare feet. Always wear shoes. Wear shoes with rubber or high-traction soles. Do not use shoes with heels, leather soles, cleats or spikes. Make sure no stones are embedded in the soles.
- Keep all loose clothing, shoelaces, and towels away from moving parts.
- Do not reach into, or underneath, the unit or tip it on its side during operation.
- Handrails may be held to enhance stability as needed, but are not for continuous use.
- Never mount or dismount the treadmill while the running belt is moving. Use the handrails whenever additional stability is required. In case of an emergency, such as tripping, grasp the handrails, and place the feet on the side platforms.
- Never walk or jog backwards on the treadmill.
- When it is necessary to immobilize the treadmill, set the display to read SELECT WORK-OUT. (Press the STOP key twice if not already there.) Then hold down the SPEED DOWN key and press the PAUSE key. The treadmill now displays “IMMOBILIZED”. In this state, the treadmill cannot be operated. The main motor, incline and waxer are all disabled. The treadmill will remain in this state across resets, power cycles, etc. To restore normal operation, repeat the same key sequence: hold down the SPEED DOWN key, and press the PAUSE key. The treadmill will display “SELECT WORKOUT” again.
- Use this appliance only for its intended use as described in this manual. Do not use attachments that have not been recommended by the manufacturer.

**SAVE THESE INSTRUCTIONS  
FOR FUTURE REFERENCE.**

# 1 DÉMARRAGE

## 1.1 CONSIGNES DE SÉCURITÉ IMPORTANTES

Lire toutes les instructions avant d'utiliser le tapis roulant.

- **DANGER:** Pour réduire les risques de décharge électrique, toujours débrancher cet appareil Life Fitness avant le nettoyage ou toute mesure d'entretien.
- **AVERTISSEMENT:** Pour réduire les risques de brûlures, d'incendies, de décharges électriques ou de blessures, chaque appareil doit absolument être branché sur une prise électrique correctement mise à la terre.
- **AVERTISSEMENT:** Conserver une zone de 2 m sur 1 m libre de toute obstruction derrière le tapis roulant (aucun mur, meuble ou autre appareil).
- **AVERTISSEMENT:** S'assurer que la dragonne d'arrêt d'urgence est attachée à l'utilisateur et fixée adéquatement au tapis roulant avant de commencer un exercice.
- Pour débrancher, mettre l'appareil hors tension au niveau de l'interrupteur d'alimentation, puis retirer la fiche de la prise électrique.
- Ne jamais faire fonctionner un produit Life Fitness dont la fiche ou le cordon d'alimentation est endommagé, ni aucun appareil qui serait tombé ou aurait été endommagé ou même partiellement plongé dans l'eau. Appeler le service clientèle de Life Fitness.
- Placer ce produit de manière à ce que l'utilisateur puisse accéder à la fiche du cordon d'alimentation.
- Tenir le cordon d'alimentation à l'écart de toute surface chauffée. Ne pas tirer l'appareil par le cordon d'alimentation; ne pas utiliser le cordon comme poignée. Ne pas faire passer le cordon sur le sol, sous le tapis roulant, ni le long de l'appareil. Se reporter à la section 1.2 pour la disposition adéquate du cordon d'alimentation.
- Si le cordon d'alimentation électrique est endommagé, il doit être remplacé par le fabricant, par un réparateur agréé ou par une personne qualifiée afin d'éviter tout danger.
- Ne pas utiliser ce produit dans des salles où des vaporisateurs aérosols sont employés ou bien où de l'oxygène est administré. Ces substances créent des risques de combustion et d'explosion.
- Les instructions de la console doivent toujours être suivies pour obtenir un fonctionnement correct.
- Une surveillance étroite est nécessaire si l'appareil est utilisé près d'enfants ou de personnes invalides ou handicapées.
- Ne pas utiliser ce produit à l'extérieur, près d'une piscine ou dans des endroits très humides.

- Ne jamais faire fonctionner d'appareil Life Fitness dont les orifices d'aération seraient bloqués. Les garder exempts de peluches, de cheveux ou de toute obstruction.
- Ne jamais rien insérer dans les ouvertures de cet appareil. Si un objet tombe à l'intérieur de l'appareil, couper l'alimentation électrique, débrancher le cordon de la prise et le récupérer avec précaution. S'il est impossible de l'atteindre, communiquer avec le service à la clientèle de Life Fitness.
- Ne jamais placer aucun liquide directement sur l'appareil, sauf dans le plateau pour accessoires ou un support prévu à cet effet. Il est recommandé d'utiliser des conteneurs munis de couvercles.
- Ne pas utiliser cet appareil pieds nus. Toujours porter des chaussures. Porter des chaussures avec des semelles en caoutchouc ou fournissant une très bonne adhérence. Ne pas utiliser de chaussures à talons, à semelles en cuir ou munies de crampons. S'assurer qu'aucun caillou n'est incrusté dans les semelles.
- Éloigner les vêtements lâches, les lacets et les serviettes des pièces en mouvement.
- Ne pas placer les mains sous l'appareil ou dans l'appareil, et ne pas le renverser sur le côté pendant le fonctionnement.
- Les rampes latérales peuvent servir à rétablir son équilibre, mais ne sont pas destinées à un usage continu.
- Ne jamais monter sur le tapis de course et ne pas en descendre jamais pendant qu'il tourne. Utiliser les rampes latérales afin de ne pas perdre l'équilibre. En cas d'urgence, par exemple, en cas de trébuchement ou de faux pas, saisir les barres latérales et placer les pieds sur les plates-formes latérales.
- Ne jamais marcher ni courir à reculons sur le tapis roulant.
- S'il est nécessaire d'immobiliser le tapis roulant, régler l'afficheur sur SELECT WORKOUT (SÉLECTIONNER EXERCICE). (Appuyer deux fois sur la touche STOP si l'afficheur n'en est pas déjà à ce point.) Maintenir ensuite la touche SPEED DOWN (RALENTISSEMENT) enfoncée et appuyer sur la touche PAUSE. L'appareil affiche désormais IMMOBILIZED (Immobilisé). Il ne peut alors plus fonctionner, Le moteur principal, le moteur en ligne et le cireur sont désactivés. Le tapis roulant restera immobilisé, même s'il est réinitialisé, mis hors tension, puis remis sous tension, etc. Le mode de fonctionnement normal ne peut être rétabli qu'au moyen de la même séquence de touches : maintenir la touche SPEED DOWN (RALENTISSEMENT) enfoncée et appuyer sur PAUSE. L'appareil affichera SELECT WORKOUT (SÉLECTIONNER EXERCICE) à nouveau.
- Cet appareil ne doit être employé que pour l'usage auquel il est destiné, conformément aux directives du manuel. Ne pas utiliser d'accessoires qui ne sont pas recommandés par le fabricant.

**CONSERVER CES INSTRUCTIONS  
POUR TOUT USAGE ULTÉRIEUR.**

## 1.2 SETUP

Read the Operation Manual before setting up the Life Fitness treadmill. Place the treadmill where it will be used before beginning the setup procedure.

### ELECTRICAL POWER REQUIREMENTS

The Life Fitness Treadmill requires a dedicated\* line according to the electrical configurations listed in the chart below.

\* One individual branch circuit for each treadmill per NEC article 210-21 (b) (1) and 210-23 (or other appropriate, country specific electrical compliance guidelines). The hot, neutral and ground wires must each be routed independently (not looped or tied to other circuits.)."

Supply Voltage (VAC)	Frequency (Hz)	Rated Current (Amps)
100	50 / 60	18
120	50 / 60	18
200	50 / 60	9
220	50 / 60	9
230	50 / 60	9
240+	50 / 60	9

**NOTE:** Do not modify the plug provided with this product. If the plug does not fit into an available electrical outlet, have a proper outlet installed by a qualified electrician.

### GROUNDING INSTRUCTIONS

This Life Fitness product must be properly grounded. If the unit malfunctions or breaks down, proper grounding provides a path of least resistance for the electric current, which reduces the risk of shock to anyone touching or using the equipment. Each unit is equipped with an electrical cord, which includes an equipment grounding conductor and a grounding plug. The plug must be inserted into an outlet that has been properly installed and grounded in accordance with all local codes and ordinances.

**A temporary adapter MUST NOT BE USED to connect this plug to a 2-pole receptacle in North America. If a properly grounded, 20 AMP outlet is not available, one must be installed by a qualified electrician. Models drawing 20-amps must be installed on a dedicated line.**

**IL EST ABSOLUMENT INTERDIT d'employer un adaptateur temporaire pour brancher cette fiche sur une prise bipolaire en Amérique du Nord. Si aucune prise de 20 A correctement mise à la terre n'est disponible, en faire installer une par un électricien qualifié. Les modèles utilisant 16 A ou plus doivent être branchés sur un circuit spécialisé.**

**DANGER:** A risk of electrical shock may result from improper connection of the equipment-grounding conductor. Check with a qualified electrician if in doubt as to proper grounding technique. **DO NOT** modify the plug provided with the product. If it will not fit an electrical outlet, have a proper outlet installed by a qualified electrician. Any modification to the electrical plug will result in a voided warranty.

**Un branchement incorrect du conducteur de mise à la terre peut entraîner des risques de décharge électrique. Consulter un électricien si des doutes subsistent quant à la technique de mise à la terre. NE PAS MODIFIER la fiche fournie avec l'appareil. Si elle ne s'adapte pas à une prise, faire installer une prise correcte par un électricien qualifié. Toute modification à la fiche annule la garantie.**

## WAX BAG INSTRUCTIONS

To install the wax bag, turn the power off at the ON/OFF switch, and unplug the unit from the electrical outlet.

**Remove the access panel.** Remove the two screws (A) securing the wax bag access panel (B), located on the user left side of the unit. Remove the panel and set it aside.

**Install the wax bag.** Verify that the wax bag protective liner (C) is open and ready to receive the wax bag (D). Remove the new wax bag from its packaging and carefully insert it into the access hole. The wax bag hose faces the rear of the unit. Remove the two wingnuts (E) located just inside the access hole. Align the mounting holes located in the wax bag flange with the two wingnut studs (F). Secure the wax bag with the two wingnuts.

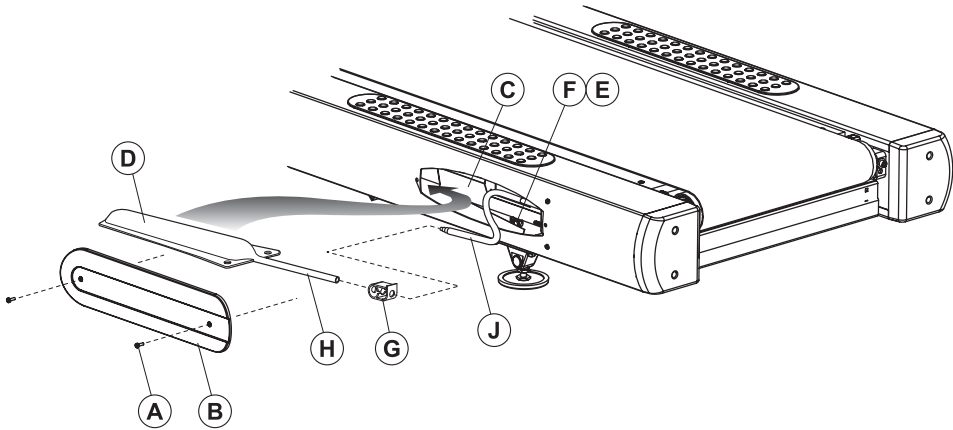

**CAUTION:** Be careful to not rip or damage the wax bag on the wingnuts or wingnut studs when inserting the new wax bag.

**MISE EN GARDE :** lors de l'insertion du nouveau sac de cire, veiller à ne pas le déchirer ni l'endommager sur les écrous à oreilles ou sur leurs goujons.

**Attach the hose clamp.** Slide the hose clamp (G) over the end of the wax bag outlet hose (H). Position the clamp approximately three inches from the end of the hose and engage it, clamping it (1) onto the wax bag hose to prevent spillage.

**Connect the wax bag hose to the pump inlet hose.** Cut the end of the wax bag hose one half-inch from the end. Slide it onto the barbed nozzle on the wax pump inlet hose (J). Be sure to fully seat the wax bag hose onto the inlet hose. Release the hose clamp (2).

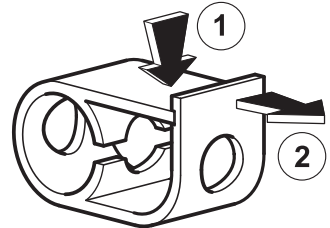

**CAUTION:** Failure to release the hose clamp will result in greatly reduced belt life.

**MISE EN GARDE :** la bride de serrage doit être relâchée sous peine de réduire de façon importante la durée de vie du tapis.

**Replace the access panel.** Replace the wax bag access panel and secure it with the two screws.

## HOW TO POSITION AND STABILIZE THE LIFE FITNESS TREADMILL

Following all safety instructions in Section 1.1, move the treadmill to the location in which it will be used. See Section 7, titled *Specifications*, for the dimensions of the footprint. Allow a distance of eight inches, or 21 centimeters, between the treadmill and other units on either side. Allow a distance of six feet, or two meters, from the rear of the treadmill to any object or surface.

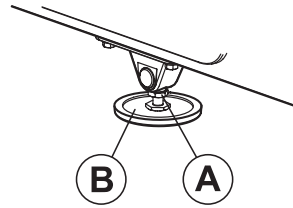

After placing the unit where it will be used, check its stability. If there is even a slight rocking motion or the unit is not stable, determine which stabilizing leg is not resting on the floor. To adjust, loosen the JAM NUT (A), and turn the STABILIZING LEG (B) until the rocking motion ceases, and both stabilizing legs rest firmly on the floor. Retighten the JAM NUT.

**NOTE:** *It is extremely important that the stabilizing leg be correctly adjusted for proper operation. An unbalanced unit may cause striding belt misalignment. A bubble level is recommended to ensure proper leveling.*

### POWER SWITCH

Located on the front panel at the base of the treadmill, the ON/OFF switch has two positions: "1" (one) for ON and "0" (zero) for OFF.

### SETTING THE CLOCK

The unit contains a clock, which is used for system maintenance and event tracking.

After the unit has been turned ON, the display will prompt for the following:

"WOULD YOU LIKE TO CHANGE THE CLOCK FROM GMT TO LOCAL TIME - IF YES PRESS ENTER - IF NO PRESS CLEAR"

If the clock setting has not been set, follow the instructions below to properly set the clock. To accept the current settings, press the CLEAR key.

To change the setting, press the ENTER key. The MESSAGE CENTER displays: "CHOOSE CLOCK DISPLAY MODE BY USING ARROW KEYS". Use an ARROW key to toggle the settings between "24 hour mode" or "12 hour mode AM/PM". To accept the mode, press the ENTER key.

The current time will be displayed in Greenwich Mean Time.

- Use the TIME arrows to change the hours
- Use the INCLINE arrows to change the minutes
- Use the SPEED arrows to change the seconds

When finished press the ENTER key. The MESSAGE CENTER displays "UPDATING CLOCK". After the clock has been updated the message center displays "clock set to local".

At this point, the clock has been reset, and the normal startup procedure continues.

If the clock setting is incorrect, follow the instructions below to change the clock setting.

*†This prompt appears for the first five times that the unit is turned on, including power-ups at the factory.*

To enter the Clock's configuration, press and hold down the PAUSE key and press the CLEAR key twice. Continue to hold down the PAUSE key until the MESSAGE CENTER displays the words "SERVICE MENU". Then, release the PAUSE key and press the QUICK START key. The MESSAGE CENTER then displays "MANAGER CONFIG". Press the TIME down arrow key once - message center displays "CLOCK CONFIGURATION". Press the Enter key to access the CLOCK CONFIG MENU.

Use arrow keys to select an item you want to change. You can select the following:

- Set Day
- Set Date
- Set Time

Press ENTER on the item you want to change. Use the arrow keys to change the item and then press ENTER. Your changes will be saved and then you will see "CLOCK SET TO LOCAL" in the display. Once you see this message you can press the CLEAR key 3 times to exit the Clock configuration mode.

## **CENTERING THE BELT**

After installing and levelling the treadmill, check the belt to ensure that it is tracking properly. First, plug the power cord into an appropriate outlet. See *Electrical Requirements* at the beginning of this section for details. Then, turn the treadmill ON.

Have one person stand on the platforms on either side of the treadmill belt. Do not stand on the belt at this time. Press the QUICK START key, and increase the speed to 4.0 miles per hour (MPH), or 6.4 kilometers per hour (KPH), using the SPEED UP arrow.

If the striding belt moves to the right while it is running, have a second person turn the right tension bolt a quarter-turn clockwise, and then turn the left tension bolt (A) a quarter-turn counter-clockwise. See the illustration below. This action sets the striding belt tracking back to center of the roller.

If the striding belt moves to the left, turn the left tension bolt a quarter-turn clockwise and then turn the right tension bolt a quarter-turn counter-clockwise to start the striding belt tracking back to center of roller.

Repeat these adjustments until striding belt appears centered. Allow the belt to continue running for several minutes to be sure that the tracking is stabilized.

**NOTE:** *Do not exceed one full turn of the adjusting screws in either direction. If, after one full turn, the belt does not track properly, contact Customer Support Services. The phone numbers are listed in Section 6.7, titled How to Obtain Product Service.*

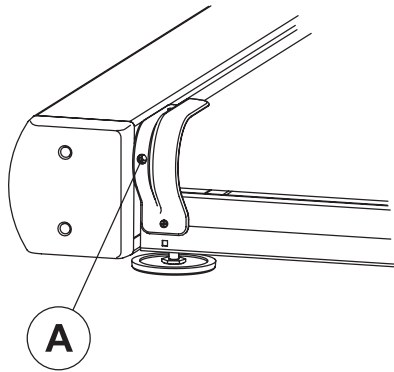

## FITNESS NETWORKING

The two interchangeable type RJ45 networking ports (A) are located on the back of the display console. These network ports, located behind the display console rear access door, allow the treadmill to be connected to a fitness entertainment system and/or a fitness network, such as FitLinxx®.

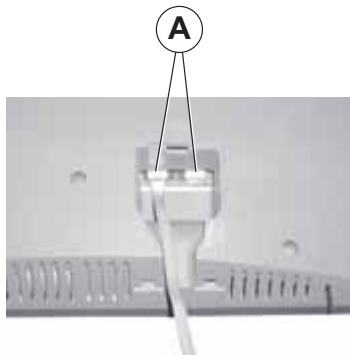

- **Networking:** The built-in network ports allow the unit to exchange workout information with a fitness network database.
- **Fitness Entertainment:** The built-in network ports allow the treadmill to power a third-party receiver for use with an entertainment system, such as the Cardio Theater® system, BroadcastVision™ or Exercise™.

## POWER CORD ROUTING

The power cord can be run straight from the treadmill, shortened and exited out the user-front left side, or run under the frame using the power cord clips and exited out the user right-rear side of the treadmill.

For efficient cord management, the following routing options are recommended:

With the power cord unplugged, insert the clips in the appropriate holes. See the illustration below. Use Hole Pattern 1 or 2 to locate the clips and secure the power cord with the clips, taking up any slack between clips.

**NOTE:** It may be necessary to tip the treadmill to route the power cord properly.

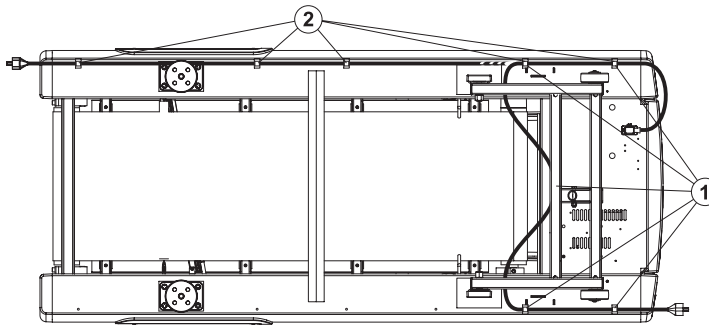

To plug the power cord into an outlet in front of the treadmill, use Hole Pattern 1 for outlets located at the front of the machine.

**NOTE:** To accommodate treadmill incline, at least two feet (24") of power cord is required between the outlet and the last power cord clip for outlets in front of the treadmill.

To plug the power cord into an outlet in rear of the treadmill, use Hole Pattern 2 for outlets located at the rear of the machine.



**WARNING:** Make sure that there is a 6-foot clearance behind the treadmill. Contact Life Fitness Customer Service for an optional longer power cord if necessary.



**WARNING:** Insure that the power cord (A) does not contact the striding belt or get pinched between the frame (C), lift arm (B) or the wheel; failure to follow this warning may result in serious injury.

**AVERTISSEMENT :** S'assurer que le cordon d'alimentation n'entre pas en contact avec le tapis et ne soit pas pincé entre le cadre, le bras de levage ou la roue. Le non-respect de cet avertissement peut provoquer de graves blessures.

**NOTE:** When using Pattern 1, it is extremely important to route the power cord BETWEEN the lift frame and the main frame.

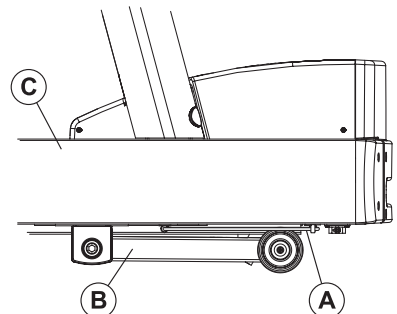

# 2 THE DISPLAY CONSOLE

## 2.1 DISPLAY CONSOLE OVERVIEW

The computerized display console on the treadmill allows the user to tailor a workout to personal fitness abilities and goals and to monitor progress. With this easy-to-use console, the user can track fitness improvement from one workout to the next.

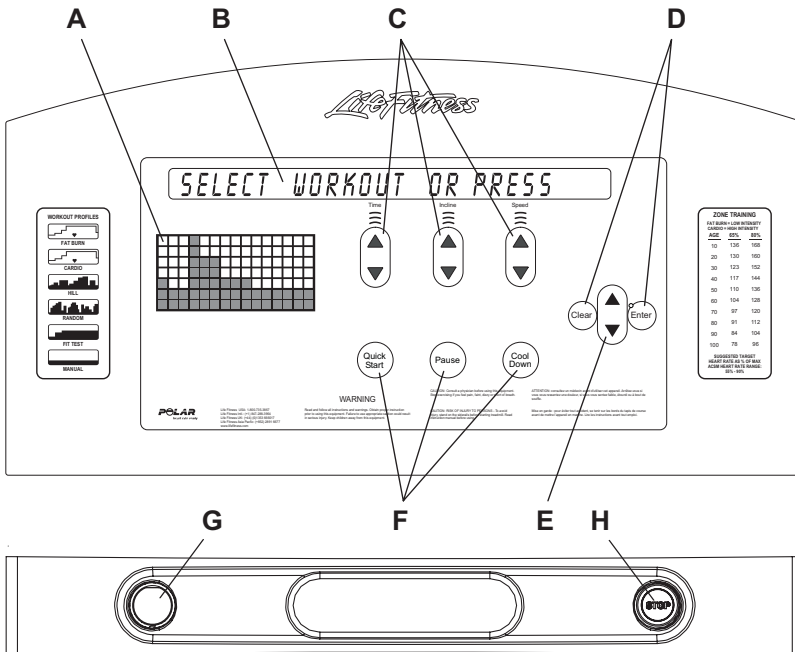

## 2.2 DISPLAY CONSOLE DESCRIPTIONS

- A **WORKOUT PROFILE WINDOW:** During a workout, interval hills and valleys appear in this window as rows of light stacked in columns. The number of lit rows within a column corresponds to an incline percentage.
- B **MESSAGE CENTER:** This window displays step-by-step instructions for setting up a workout. During a workout, it displays calories, distance, time, incline, speed, and heart rate. Additionally, the MESSAGE CENTER displays calories per hour, METS, Watts, pace in minutes per mile/kilometer, and distance climbed, if enabled to do so in the Manager's Configuration. See Section 5.1, titled *Entering and Using the Manager's Configuration*.
- C **TIME, INCLINE, and SPEED ARROW keys:** Press these keys to increase or decrease the workout time, the incline of the treadmill deck, or the striding belt speed.
- D **CLEAR key:** Press this key once to clear data not yet entered. Press twice in succession, while programming, to reset the treadmill and restart the programming sequence.
- ENTER key:** Press this key to confirm entries of workout setup values, as displayed in the MESSAGE CENTER.
- E **WORKOUT SELECTION ARROW keys:** When setting up a workout, use these keys to scroll through workout options as they appear in the MESSAGE CENTER. Also, use these keys set up workout or Manager's Configuration options.
- F **QUICK START:** Press this key to begin a manual workout immediately, without having to select a workout program. Once the workout is in progress, use the ARROW KEYS to change the intensity level or workout duration as desired.
- COOL DOWN:** Press this key to begin an automatically customized workout cool-down.
- PAUSE:** Press this key to stop the belt and hold the current workout. Continue the workout by pressing the PAUSE key a second time or by pressing the ENTER key.
- The Life Fitness Treadmill is equipped with a manual emergency stop system. Use either of the two features described below to stop the treadmill immediately.
- G A circular-shaped STOP magnet is located on the left side of the panel below the display console. A cord with a clip is attached to this button. Before starting a workout, attach the clip to clothing. To stop the striding belt on the treadmill, pull the cord, removing the magnet from the console. Replace the magnet to reset the system.

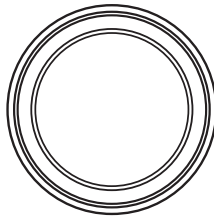

- H A circular-shaped STOP button is located on the right side of the panel below the display console. Press the button to stop the striding belt and end the current workout.



## 2.3 READING RACK AND ACCESSORY TRAYS

The display console design includes a built-in reading rack (A) allowing a book or magazine to be supported during the workout. Also included in the display console are three built-in accessory trays (B). Two side trays to accommodate large items such as water bottles and one center tray for smaller items such as personal media devices.

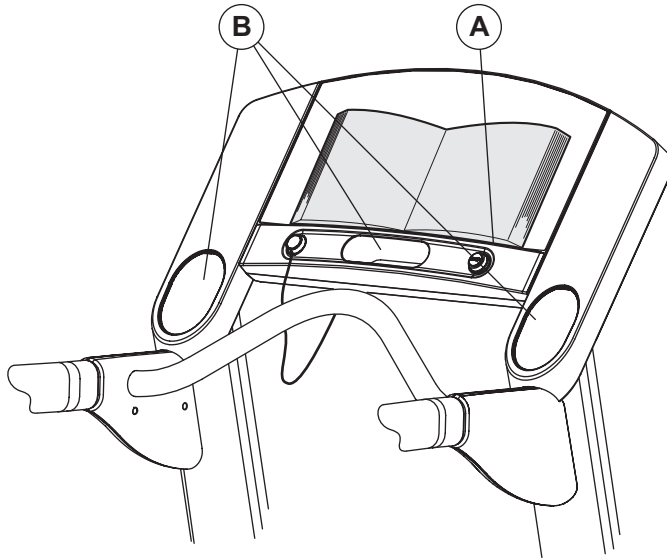

# 3 HEART RATE ZONE TRAINING® EXERCISE

## 3.1 WHY HEART RATE ZONE TRAINING® EXERCISE?

Research shows that maintaining a specific heart rate while exercising is the optimal way to monitor the intensity of a workout and to achieve maximum results. That is the idea behind the Life Fitness Heart Rate Zone Training® approach to exercise.

Zone Training identifies an exerciser's ideal heart rate range, or zone, for burning fat or increasing cardiovascular fitness. The zone is a percentage of the theoretical maximum<sup>†</sup>, and its value depends on the workout. The Life Fitness Treadmill features exclusive workouts designed to take full advantage of the benefits of Heart Rate Zone Training® exercise. **FAT BURN** targets a recommended heart rate that is 65 percent of the theoretical maximum<sup>†</sup> (HRmax), and **CARDIO** targets 80 percent.

**NOTE:** Consulting a fitness trainer is recommended for defining specific fitness goals and designing a workout program.

To change the target heart rate during a workout, simply enter a new target heart rate using the SELECTION ARROWS.

The Heart Rate Zone Training® workouts measure heart rate. Wear a telemetry chest strap to enable the treadmill's on-board computer to monitor the heart rate during a workout. The computer automatically adjusts the incline level to maintain the target heart rate based on the actual heart rate.

ZONE TRAINING		
FAT BURN = LOW INTENSITY		
CARDIO = HIGH INTENSITY		
AGE	65%	80%
10	136	168
20	130	160
30	123	152
40	117	144
50	110	136
60	104	128
70	97	120
80	91	112
90	84	104
100	78	96

SUGGESTED TARGET  
HEART RATE AS % OF MAX  
ACSM HEART RATE RANGE:  
55% - 90%

<sup>†</sup> Defined by the American College of Sports Medicine's "Guidelines for Exercise Testing and Prescription" as equal to 220 minus an individual's age.

## 3.2 HEART RATE MONITORING

### THE OPTIONAL HEART RATE CHEST STRAP

The Life Fitness Treadmill is equipped with Polar® telemetry, a heart rate monitoring system in which electrodes, pressed against the skin, transfer heart rate signals to the treadmill console. These electrodes are attached to a chest strap that the user wears during the workout. The chest strap is optional. To order it, call Life Fitness Customer Support Services at 1-800-351-3737.

See the diagram below for correct positioning of the strap. The electrodes (A), which are the two grooved surfaces on the underside of the strap, must remain wet to transmit accurately the electrical impulses of the heart back to the receiver. Moisten the electrodes. Then, secure the strap as high under the chest muscles as possible. The strap should be snug, but comfortable enough to allow for normal breathing.

The transmitter strap delivers an optimal heart rate reading when the electrodes are in direct contact with bare skin. However, it functions properly through a thin layer of wet clothing.

If it becomes necessary to re-moisten the chest strap electrodes, grasp the center of the strap, pull it away from the chest to expose the two electrodes, and re-moisten them.

During the setup of a heart rate zone training workout, the user will be required to enter a start-up speed. If a heart rate chest strap is not detected, the maximum allowable speed is 4.5 mph. If a heart rate chest strap is detected, the maximum speed is 12 mph.

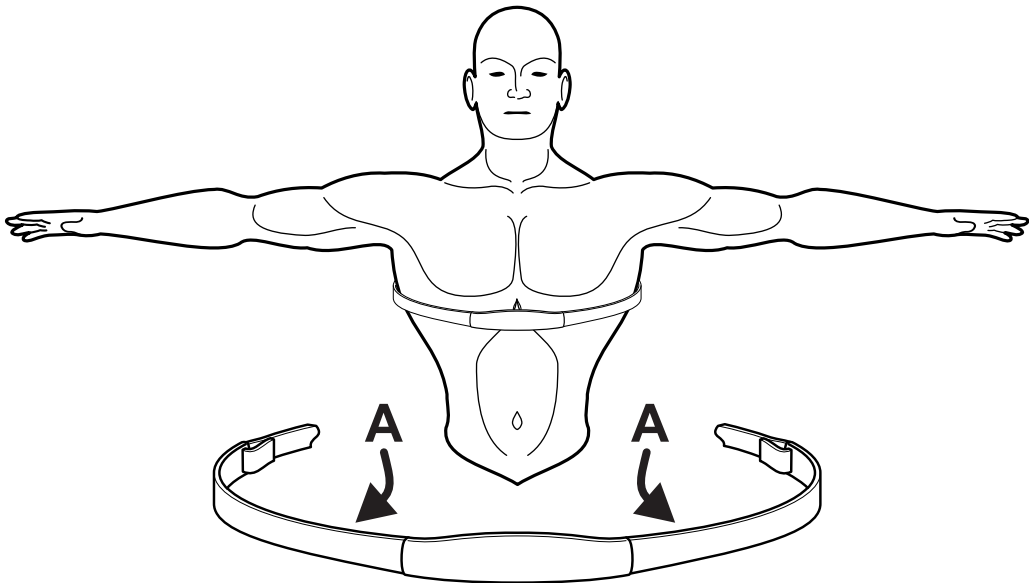

# 4 THE WORKOUTS

## 4.1 WORKOUT OVERVIEWS

The following workouts are preprogrammed for the Life Fitness Treadmill.

**QUICK START** is the fastest way to begin exercising. After the QUICK START key is pressed, a MANUAL workout begins.

**FAT BURN** is a low-intensity workout for burning the body's fat reserves. The user wears a heart rate chest strap. The program adjusts the intensity level through changing the incline (elevation), based on the actual heart rate, to maintain the rate at 65 percent of the theoretical maximum†.

**CARDIO** is a higher intensity workout for more fit users, emphasizing cardiovascular benefits and maximum fat burning. The user wears a heart rate chest strap. The program adjusts the intensity level, based on the actual heart rate, to maintain the rate at 80 percent of the theoretical maximum.

**HILL** is an interval training workout. Intervals are periods of intense aerobic exercise separated by regular periods of lower-intensity exercise.

**RANDOM** is an interval training workout of constantly changing intensity levels that occur in no regular pattern or progression.

**MANUAL** is a constant effort workout in which the user can change resistance level or speed at any time.

**FIT TEST** is a five-minute workout with which the user can measure cardiovascular fitness compared to other people of the same age and gender.

## 4.2 USING THE WORKOUTS

Select a workout OR log on to a fitness network exercise database. See Section 4.5, titled *Logging on to the Network* for details. The chart below lists the steps for setting up each workout.

To select a workout, use the WORKOUT SELECTION ARROW keys to scroll through workout options displayed in the MESSAGE CENTER. The treadmill's Hold-n-Scroll feature enables the user to scroll automatically through options simply by holding down an ARROW key, making it unnecessary to press the ARROW key repeatedly. Press the ENTER key to confirm a displayed selection. Then, enter data requested in MESSAGE CENTER prompts. Use the TIME, INCLINE, or SPEED ARROW keys to scroll to desired values as displayed in the MESSAGE CENTER, and press ENTER to confirm each selection. Values can be changed during all workouts, except for **FIT TEST**.

## 4.3 WORKOUT DESCRIPTIONS

### LIFE FITNESS TREADMILL WORKOUT SETUP STEPS

#### QUICK START

Press QUICK START  
Begin workout

#### MANUAL

Select MANUAL  
Enter weight  
Enter time  
Enter incline  
Enter speed  
Begin workout

#### HILL

Select HILL  
Enter weight  
Enter time  
Enter level  
Enter speed  
Begin workout

#### RANDOM

Select RANDOM  
Enter weight  
Enter time  
Enter level  
Enter speed  
Begin workout

#### FIT TEST\*\*

Select FIT TEST  
Enter weight  
Enter age  
Enter gender  
Enter speed  
Begin workout

#### FAT BURN\*\*

Select FAT BURN  
Enter weight  
Enter time  
Enter age  
Enter THR\*  
Enter speed  
Begin workout

#### CARDIO\*\*

Select CARDIO  
Enter weight  
Enter time  
Enter age  
Enter THR\*  
Enter speed  
Begin workout

\* Target Heart Rate (THR) is a percentage of the theoretical maximum. For example, a 40-year-old user's THR for the CARDIO workout is 144. The CARDIO workout targets 80 percent of the maximum, so the equation would be  $(220-40) \times .80 = 144$ .

\*\* This workout requires the user to wear the telemetry chest strap.

### QUICK START

**QUICK START** is the fastest way to begin exercising. After the QUICK START key is pressed, a MANUAL workout begins. For accurate caloric expenditure, enter weight when prompted by the message center using the SELECTION keys. The prompt will appear ten seconds after the workout begins. The incline level is set to zero by default. Change the level using the INCLINE ARROW key. Change the speed using the SPEED key, up or down as desired.

### MANUAL

The **MANUAL** program is a constant effort workout in which the user can change resistance level or speed at any time.

# HILL

The Life Fitness-patented **HILL** workout offers a variety of configurations for interval training. Intervals are periods of intense cardiovascular exercise separated by regular periods of lower-intensity exercise. The **WORKOUT PROFILE** window represents these high and low intervals as columns of light, which together have the appearance of hills and valleys.

The computerized interval training workout has been scientifically demonstrated to promote greater cardio-respiratory improvement than steady-pace training.

The **HILL** workout goes through four phases, each marked by different intensity levels. The **WORKOUT PROFILE** window displays the progress of these phases, as seen in the chart following these descriptions below. As noted in the descriptions, the heart rate should be measured at two stages in the workout to gauge its effectiveness. To do so, wear the chest strap. Note that the **MESSAGE CENTER** does not display a request for a heart rate measurement, as it does with the **CARDIO** and **FAT BURN**.

- 1 **Warm-up** is a phase of low, gradually rising resistance, which brings the heart rate into the lower end of the target zone and increases respiration and blood flow to working muscles.
- 2 **Plateau** increases the intensity slightly, and keeps it steady, to bring the heart rate to the low end of the target zone. Check the heart rate at the end of this phase.
- 3 **Interval Training** is a series of increasingly steeper hills, alternating with valleys, or stints of recovery. The heart rate should rise to the high end of the target zone. Check the heart rate at the end of this phase.
- 4 **Cool-down** is a low-intensity phase that allows the body to begin removing lactic acid, and other exercise by-products, which build up in muscles and contribute to soreness.

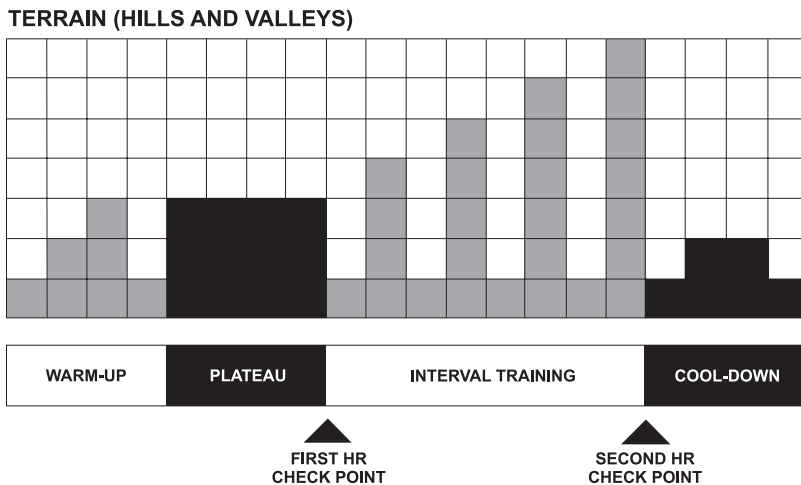

Each column, as seen in the **WORKOUT PROFILE WINDOW** and the chart above, represents one interval. The overall duration of the workout determines the length of each interval. Each workout is made up of 20 intervals, so the duration of each interval is equal to the duration of the entire workout divided by 20.

**1 to 9 minutes:** A workout with a duration of less than 10 minutes is insufficient for the **HILL** program to complete all four phases adequately. The program, therefore, condenses a workout of this duration at various stages.

**10 to 19 minutes:** The interval durations initially are set at 30 seconds for a 10-minute workout. For every minute over 10, each interval increases by three seconds. A 15-minute workout consists of 20 intervals at 45 seconds each.

**20 to 99 minutes:** All intervals last 60 seconds. If the user adds minutes to the pre-set duration while the workout is in progress, the program adds hills and valleys that are identical to the first eight intervals of the Interval Training phase. This pattern repeats until the workout is completed.

## **RANDOM**

The **RANDOM** program creates a terrain of hills and valleys that varies with each workout. More than one million different patterns are possible.

## **FIT TEST**

The treadmill Fit Test program is another exclusive feature of this versatile treadmill. The Fit Test workout measures cardiovascular fitness and can be used to monitor improvements in endurance every four to six weeks. The user must grasp the hand sensors (if equipped) when prompted or wear a heart rate chest strap, as the test score calculation is based on a heart rate reading. The workout duration will be five minutes at a 5% incline. Immediately afterward, the console will take the user's heart rate reading, calculate a fitness score, and display the score in the MESSAGE CENTER.

The Fit Test is considered to be a submax VO<sub>2</sub> (volume of oxygen) test. It gauges how well the heart supplies oxygenated blood to the exercising muscles, and how efficiently those muscles receive oxygen from the blood. Physicians and exercise physiologists generally regard this test as a good measure of aerobic capacity.

To set up the Fit Test:

- Press the **WORKOUT SELECTION ARROW KEYS** button repeatedly until the **FIT TEST** option appears in the message center. Press **ENTER** to select the **FIT TEST** option.
- The message center will prompt for a user weight (**ENTER WEIGHT**). Use the **UP/DOWN ARROW KEYS** to input your weight. Press **ENTER** to accept the weight.
- The message center will next prompt for a user age (**ENTER AGE**). Use the **UP/DOWN ARROW KEYS** to input your age. Press **ENTER** to accept the age.
- The message center will next prompt for a user gender (**SELECT GENDER**). Using the **UP/DOWN ARROW KEYS**, select a gender. Press **ENTER** to accept the gender selection.
- The message center will next prompt for a workout level (**ENTER SPEED**)(2-4.5 mph). Consult the following recommended fit test level chart for an appropriate effort level based on your age, gender and activity level. Use the **UP/DOWN SPEED ARROW KEYS** to enter the corresponding level.

After the five-minute **FIT TEST** is completed, a **FIT TEST** score will be displayed.

## FIT TEST PROGRAM SUGGESTED EXERTION LEVELS

	Inactive	Active	Very Active
Treadmill Fit Test Level	2-3 mph	3-4 mph	3.5-4.5 mph
	3.2-4.8 kph	4.8-6.4 kph	5.6-7.2 kph

**NOTE:** Treadmill will incline to 5% after a one minute warm-up.

Suggested exertion levels should be used as a guideline for setting up the Fit Test program. The goal is to elevate the user's heart rate to a level that is between 60%-85% of their theoretical maximum heart rate (220-age).

Within each suggested range, these additional guidelines can be used:

Lower Half of Range	Upper Half of Range
higher age	lower age
lower weight	higher weight*
shorter	taller

\* In cases of excessive weight, use lower half of range

The computer will not accept:

- heart rates less than 52 or greater than 200 beats per minute
- body weights less than 75 pounds (34 kg) or greater than 400 pounds (181 kg)
- ages below 10 or over 99 years
- data input that exceeds human potential

If you make an error when entering any Fit Test data, you can correct it by pressing CLEAR, inputting the correct information, and pressing ENTER.

It is important for you to take the Fit Test under similar circumstances each time. Your heart rate is dependent on many factors, including:

- amount of sleep the previous night (at least seven hours is recommended)
- time of day
- time you last ate (two to four hours after the last meal is recommended)
- time since you last drank a liquid containing caffeine or alcohol, or smoked a cigarette (at least four hours is recommended)
- time since you last exercised (at least six hours is recommended)

For the most accurate Fit Test results, you should perform the Fit Test on three consecutive days and average the three scores.

**NOTE:** To receive a proper Fit Test score, the work done must be within a training heart rate zone that is 60 percent to 85 percent of the theoretical maximum heart rate (HRmax). This rate is defined by the American College of Sports Medicine's "Guidelines for Exercise Testing and Prescription" as equal to 220 minus an individual's age.

The tables below list fit test results.

### RELATIVE FITNESS CLASSIFICATION FOR MEN

<b>Men</b>	<b>Estimated VO2 Max (ml/kg/min) Per Age Category</b>				
<b>Rating</b>	<b>20-29</b>	<b>30-39</b>	<b>40-49</b>	<b>50-59</b>	<b>60+</b>
Elite	52+	51+	48+	45+	42+
Excellent	50-51	48-50	46-47	42-44	39-41
Very Good	47-49	45-47	43-45	40-41	36-38
Above Average	44-46	42-44	40-42	37-39	33-35
Average	41-43	39-41	37-39	34-36	30-32
Below Average	38-40	36-38	34-36	31-33	27-29
Low	35-37	33-35	31-33	28-30	24-26
Very Low	<35	<33	<31	<28	<24

### RELATIVE FITNESS CLASSIFICATION FOR WOMEN

<b>Women</b>	<b>Estimated VO2 Max (ml/kg/min) Per Age Category</b>				
<b>Rating</b>	<b>20-29</b>	<b>30-39</b>	<b>40-49</b>	<b>50-59</b>	<b>60+</b>
Elite	44+	42+	39+	35+	34+
Excellent	42-43	40-41	37-38	33-34	32-33
Very Good	39-41	37-39	35-36	31-32	30-31
Above Average	37-38	35-36	32-34	29-30	28-29
Average	34-36	32-34	30-31	27-28	25-27
Below Average	31-33	29-31	27-29	25-26	23-24
Low	28-30	27-28	25-26	22-24	20-22
Very Low	<28	<27	<25	<22	<20

Life Fitness developed this rating scale based on VO2 max percentile distributions referenced in *American College of Sports Medicine's "Guidelines for Exercise Testing and Prescription"* (6th Ed. 2000). It is designed to provide a qualitative description of a user's VO2 max estimation, and a means of assessing initial fitness level and tracking improvement.

## FAT BURN

The **FAT BURN** workout is designed to maintain a user's heart rate at 65 percent of the theoretical maximum<sup>†</sup> for optimal results. Throughout the workout, the user wears a chest strap. The console continuously monitors and displays the heart rate, adjusting the intensity level of the treadmill to reach and maintain the target\*. This system eliminates over- and under-training, and it maximizes the aerobic benefits of exercise by using the body's fat stores for fuel.

**NOTE:** *The intensity level is changed by incline. Speed can be only changed by the user*

## CARDIO

The **CARDIO** workout is virtually identical to **FAT BURN**; however, the target heart rate is calculated at 80 percent of the theoretical maximum\*\*. The higher target promotes cardiovascular improvement by placing a heavier workload on the heart muscle.

**NOTE:** *The user can change the target heart rate at any time during a FAT BURN or CARDIO workout by using the WORKOUT SELECTION ARROW keys.*

<sup>†</sup> Defined by the American College of Sports Medicine's "Guidelines for Exercise Testing and Prescription" as equal to 220 minus an individual's age.

\* Target Heart Rate (THR) is a percentage of the theoretical maximum (HRmax). For example, a 40-year-old user's recommended THR for the FAT BURN workout is 117, or 65 percent of the maximum, so the equation would be  $(220-40) \times .65 = 117$ .

\*\* Target Heart Rate (THR) is a percentage of the theoretical maximum (HRmax). For example, a 40-year-old user's recommended THR for the CARDIO workout is 144, or 80 percent of the maximum, so the equation would be  $(220 - 40) \times .80 = 144$ .

## 4.4 MAXIMIZING WORKOUTS ON A LIFE FITNESS TREADMILL

### SELECTING AN INTENSITY LEVEL

The steps for setting up a **HILL** or **RANDOM** workout include selecting a level. The word “level” refers to a range of incline percentages. The treadmill features 20 levels, with Level 1 having the lowest average incline grade and Level 20 having the highest.

<b>LEVEL</b>	<b>% Incline</b>	<b>LEVEL</b>	<b>% Incline</b>
1	0.0 - 1.5	11	2.0 - 8.5
2	0.0 - 2.2	12	3.0 - 9.2
3	0.0 - 2.9	13	3.5 - 9.9
4	0.0 - 3.6	14	5.0 - 10.6
5	0.0 - 4.3	15	5.5 - 11.3
6	0.0 - 5.0	16	6.5 - 12.0
7	0.0 - 5.7	17	7.0 - 12.7
8	0.0 - 6.4	18	8.0 - 13.4
9	0.5 - 7.1	19	8.7 - 14.1
10	1.5 - 7.8	20	9.0 - 15.0

Within each level are seven incline percentages, or hills. During a workout, each hill appears in the **WORKOUT PROFILE** window as rows of light stacked in a column. The number of lit rows within a column corresponds to an incline percentage. For example, in Level 5, the lowest incline is 0.0 percent and is represented as one lit row. The highest incline, 4.3 percent, is represented by a column with all seven rows lit.

In the **HILL** and **RANDOM** workouts, these varying hills occur for equal durations, as discussed in the **HILL** workout description. When the workout program brings up a new hill, the incline percentage changes automatically to match that hill.

To change levels during a workout, use any of the **ARROW** keys.

### USING INSTAPACE™ FEEDBACK

The InstaPace™ Feedback feature enables users to monitor their pace, or rate of minutes per mile, while running on the treadmill. This feature must be enabled in the Manager's Configuration. See Section 5, titled *The Manager's Configuration*, for more information. When the user adjusts the treadmill speed, using the **SPEED ARROW KEYS**, the **MESSAGE CENTER** displays the **MPH** and pace simultaneously.

### USING ZEROUT™ SPEED CONTROL

If, during a workout, a user decreases the speed to the minimum and continues to hold the **DECREASE SPEED ARROW**, the speed falls to 0 **MPH**, which is pause mode. The minimum speed is 0.5 **MPH**, unless changed in the Manager's Configuration. See section 5.2, titled *Configuration Settings*, for more information.

### COOL-DOWN

Life Fitness' unique Cool-Down Protocol automatically customizes every cool-down based on

each user's workout performance. Workout performance factors, such as speed, incline, duration, and heart rate, determine the duration and intensity of the cool-down.

### **HOLD-N-SCROLL**

This feature enables the user to scroll automatically through options simply by holding down an ARROW key, making it unnecessary to press the ARROW key repeatedly.

## **4.5 LOGGING ON TO THE NETWORK**

When the treadmill is connected to a network, the MESSAGE CENTER displays a prompt to log on with a personal ID number. Press ENTER. Then, for each digit of the ID number, use the ARROW keys to scroll through the displayed numerals, and press ENTER when the correct numeral appears. Repeat this step for each digit.

# 5 THE MANAGER'S CONFIGURATION

## 5.1 ENTERING AND USING THE MANAGER'S CONFIGURATION

To enter the Manager's Configuration, press and hold down the PAUSE key and press the CLEAR key twice. Continue to hold down the PAUSE key until the MESSAGE CENTER displays the words "SERVICE MENU". Then, release the PAUSE key, press the QUICK START key, and press ENTER. The MESSAGE CENTER then displays, in turn, each of the configuration settings.

Use the TIME arrow keys to scroll through the list of settings, or allow the MESSAGE CENTER to scroll automatically through the options. To stop the automatic scrolling, press the PAUSE key. To resume the automatic scrolling, press the PAUSE key again. To select a displayed option, press the ENTER key.

The Manager's Configuration settings are listed on the following page in the order in which they appear in the MESSAGE CENTER display. Use the INCLINE or SPEED keys to change settings. In most cases, changing a setting means turning it on or off. See the table on the following page for more information.

## 5.2 CONFIGURATION SETTINGS

CONFIGURATION SETTING	FACTORY DEFAULT	DESCRIPTION
LANGUAGE	ENGLISH	The language of the MESSAGE CENTER display. Choices include Portugese, Spanish, Dutch, Japanese, Italian, French, and German.
MAXTIME™ SETUP	OFF	This feature enables fitness club managers to set workout duration limits during peak and non-peak hours of club traffic. If the setup is off, no duration limits are set. See the topic titled <i>Using the Maximum Time Setup</i> , which appears on the following page.
STANDBY MODE SETUP	OFF	This feature enables fitness club managers to set periods at which the treadmill automatically powers up or powers down. See the topic titled <i>Using the Standby Mode Setup</i> , which appears on the following page.
ENGLISH/METRIC UNITS	ENGLISH	The measurement unit type for weight, distance, and speed.
TELEMETRY	ON	Switching on the telemetry feature makes it possible to use the Polar®-compatible Heart Rate Zone Training® exercise chest strap for monitoring the heart rate.
SMART STOP	OFF	This feature is not available on this model.
MAXIMUM SPEED	10.0 (MPH) for U.S. 12.0 for international	This is the fastest speed at which the treadmill can operate.
MINIMUM SPEED	0.5 (MPH)	This is the slowest speed at which the treadmill can operate.
PAUSE TIMEOUT	1 (minute)	This is the maximum time during which a workout can remain in pause mode.
WATTS DISPLAY	OFF (Int'l: ON)	If this option is enabled, the MESSAGE CENTER displays the Watts equivalent of the step rate.
METS DISPLAY	OFF	If this option is enabled, the MESSAGE CENTER displays the METs equivalent of the step rate.
PACE DISPLAY	ON	This feature displays the rate of minutes per mile.
CALORIE PER HOUR DISPLAY	ON (Int'l: OFF)	If this option is enabled, the MESSAGE CENTER displays the number of calories burned per hour during the workout.
DISTANCE CLIMBED DISPLAY	OFF	The total distance climbed, based on the incline and speed of the treadmill.
WAX REMINDER	OFF	After the first 100 hours, then every 168 hours, the MESSAGE CENTER displays, "MAINTENANCE REMINDER - CLEAN THE NOZZLE."
ACCELERATION RATE	3	The rate at which the treadmill accelerates to the selected speed, ranging from 1 (slowest) to 5 (fastest).
DECELERATION RATE	3	The rate at which the treadmill decelerates to the selected speed, ranging from 1 (slowest) to 5 (fastest).
MAXIMUM INCLINE	15.0	This option changes the maximum incline grade to a value lower than 15 percent.
START MESSAGE SETUP	N/A	See "Using the START MESSAGE Setup" in this section.

## USING THE START MESSAGE SETUP

This configuration allows for a custom start-up message to be displayed before the default “Select Workout or Press Quick Start” message. The custom message can contain up to 52 characters.

### CREATING A START MESSAGE

After entering the Manager’s Configuration, scroll to the START MESSAGE SETUP option and press ENTER. Use the SPEED ARROW keys to select an available letter, number or special character. Use the INCLINE ARROW keys to move forward or backward throughout the message, or insert spaces, one character at a time. The current character will blink until the position is moved with the INCLINE ARROW keys.

### SAVING A START MESSAGE

To save the START MESSAGE, press ENTER. “MESSAGE SAVED” will appear in the message center confirming the message has been saved. To exit the start message setup without saving, press the clear key twice. “MESSAGE NOT SAVED” will appear in the message center confirming the message has not been saved.

### ERASING A START MESSAGE

After entering the Manager’s Configuration, scroll to the START MESSAGE SETUP option and press ENTER. Press enter to enter the current START MESSAGE. Press the COOL DOWN key to erase the current START MESSAGE. “MESSAGE ERASED” will appear in the message center stating the message has been erased.

## USING THE MAXTIME™ SETUP

This feature allows the club to set different maximum workout durations to accommodate various traffic flows throughout the day. The real-time clock must be correct to fully utilize this feature. Refer to Section 1.2 *Setting the Clock*.

After entering the Manager’s Configuration, select the MAXTIME SETUP option. The MESSAGE CENTER displays the statement “MAXTIME CONTROL OFF” and then displays a maximum workout duration value. The default value is 60 minutes, and it can be changed with the INCLINE or SPEED ARROW keys. This value is always in effect unless the MaxTime™ control feature is turned on.

To turn the feature on, use the INCLINE or SPEED ARROW keys, and switch the setting to MAX-TIME CONTROL ON. Then, press ENTER.

The MESSAGE CENTER displays a “peak duration” value, which is the maximum possible workout duration, in minutes, during high-traffic hour for fitness clubs. Use the ARROW keys to increase or decrease the displayed value, and press ENTER. The MESSAGE CENTER then displays a “non-peak duration” value, which is the maximum possible workout duration all other times. Use the ARROW keys to increase or decrease the displayed value, and press ENTER.

The MESSAGE CENTER then displays a “peak 1” time period in hours and minutes. This is the period during which the peak workout duration value is in force. Use the TIME ARROW keys to change the hours, and use the INCLINE ARROW keys to change the minutes. Press ENTER. The MESSAGE CENTER then displays the “peak 1” duration value, which is the amount of time in minutes that the peak period remains in force. Using the ARROW keys, change the value, and press ENTER.

The MESSAGE CENTER then displays a “peak 2” time period. Repeat the steps described in the preceding paragraph to set up a second peak time.

## USING THE STANDBY SETUP

This feature will automatically turn the treadmill power off and on at designated times, typically at the opening and closing of a facility. The real-time clock must be correct to fully utilize this feature. Refer to Section 1.2 *Setting the Clock*.

Select the STANDBY SETUP option. The MESSAGE CENTER displays the statement, "STANDBY DISABLED". Using the ARROW keys, switch the setting to ENABLED. The MESSAGE CENTER displays an "auto off" value, which is the time of day, in hours and minutes, at which the treadmill automatically switches off. Use the TIME ARROW key to change the hours, and use the INCLINE ARROW key to change the minutes. Press Enter. The MESSAGE CENTER displays an "auto on" value, which is the time of day, in hours and minutes, at which the treadmill automatically switches on.

# 6 SERVICE AND TECHNICAL DATA

## 6.1 PREVENTATIVE MAINTENANCE TIPS

The Life Fitness treadmill is backed by the engineering excellence and reliability of Life Fitness and is one of the most rugged and trouble-free pieces of exercise equipment on the market today. Commercial Life Fitness treadmills are among the most popular of aerobic trainers, regularly standing up to marathon use - 18 hours a day, seven days a week - in health clubs, colleges and military facilities the world over.

**NOTE:** *Safety of the equipment can be maintained only if the equipment is examined regularly for damage or wear. Keep the equipment out of use until defective parts are repaired or replaced. Pay special attention to parts that are subject to wear, as outlined below.*

The following preventive maintenance tips will keep the Life Fitness treadmill operating at peak performance:

- Clean the display console and all exterior surfaces regularly with mild soap and water or a mild household cleaner. DO NOT use paper towels, ammonia or acid based cleaners.\*
- Check operation of the emergency stop system once a week.
- Check the operation of the stop button once a week.
- Inspect and vacuum the area directly surrounding and under the unit regularly.
- Vacuum around the striding belt regularly to keep debris from accumulating.
- Inspect exterior parts regularly for wear, particularly the striding belt, deck and line cord.
- Check to make sure the unit is properly leveled.
- Check the position (centering) of the striding belt.

The optimum operating position of the striding belt is from 1.5 inches (38 mm) to 2.0 inches (51 mm) from either side of the frame. If the striding belt travels beyond this position, see section 6.5, titled *How to Adjust and Tension the Striding Belt*, or contact Life Fitness Customer Support Services, for proper alignment instructions, 1-800-351-3737 (USA).

**\*NOTE:** *When cleaning the exterior of the unit, a non-abrasive cleaner and soft cotton cloth are strongly recommended. At no time should cleaner be applied directly to any part of the equipment; use non-abrasive cleaner on a soft cloth and then wipe the unit. Contact Life Fitness customer Support Services for more details (See Section 6.7 - "How to Obtain Product Service").*

## 6.2 PREVENTATIVE MAINTENANCE SCHEDULE

Follow the schedule below to ensure proper operation of the product.

ITEM	WEEKLY	MONTHLY	QUARTERLY	BI-ANNUAL	ANNUAL
<b>DISPLAY CONSOLE ASSEMBLY</b>					
Hardware			Inspect		
Overlay	Clean			Inspect	
Accessory Cups	Clean				Inspect
Stop Switch	Clean			Inspect	
Emergency Switch/Magnet	Clean			Inspect	
<b>HANDLEBAR ASSEMBLY</b>					
Hardware				Inspect	
Ergo™ Front Handlebar	Clean			Inspect	
Side Hand Rails	Clean			Inspect	
Lifepulse Sensors	Clean/Inspect				
<b>FRAME ASSEMBLY</b>					
Hardware				Inspect	
Motor Cover	Clean				
Motor Electronic Compartment		Vacuum Clean		Inspect	
Drive Belt				Inspect	
Drive Belt Anti-Static Bracket		Inspect			
Anti-Static Cords		Inspect			
Leg Levelers		Inspect/Adjust			
Front Roller				Inspect	
Rear Roller				Inspect	
Side Step Area	Clean		Inspect		
<b>WAX SYSTEM</b>					
Wax Bag			Inspect		
Wax System					Inspect
Wax Nozzle				Inspect - Clean as necessary	
<b>GENERAL</b>					
Machine Level	*Inspect				
Striding Belt Centered	Inspect				
Frame, Toe Guards, Endcaps		Visual Inspect			
Tinsel	Visually Inspect if Treadmill has been Moved Replace Tinsel if Changing Belt and Deck				
*Use bubble level to inspect					

## 6.3 TROUBLESHOOTING THE TREADMILL

Malfunction	Probable Cause	Corrective Action
No Power	On/Off switch.	Turn the switch to the ON position.
	Insufficient power source.	<p>Plug treadmill into a dedicated 20 amp circuit. Refer to the Operations Manual.</p> <p>Using a voltmeter, verify power at outlet. If no power exists, reset circuit breaker at panel.</p>
	Damaged line cord.	Replace line cord. Contact Life Fitness Customer Support Services*.
	Line cord improperly seated in socket.	Inspect power connection at wall outlet and at machine for proper contact.
	Tripped circuit breaker.	<p>Verify that circuit breaker is not open. If open, reset circuit breaker.</p> <p>The location of the circuit breaker is on the outside of the treadmill, next to the ON/OFF switch. The breaker is a circular disk with a white button. The white button will have popped out. Press the white button at it's center to reset the circuit breaker.</p>

\* See Section 6.7 "How to Obtain Product Service" for contact information.

## TROUBLESHOOTING THE TREADMILL (CONTINUED)

Malfunction	Probable Cause	Corrective Action
Striding Belt slips off-center	Uneven floor surface.	Check levelers and level treadmill.  Check striding belt & re-tension as necessary. Refer to Section 6.5 "How to Adjust and Tension the Striding Belt."
Maximum speed is reduced	User is pushing striding belt. This occurs when the runner is running faster than the striding belt will travel, with the result of the striding belt being pushed with the runner's feet.	Instruct users not to push striding belt in either direction.
	User is stalling striding belt. This will occur with heavier users at lower striding belt speeds. The striding belt will "stall" if the user is traveling slower than the striding belt speed.	
	Wax system malfunction.	Verify wax nozzle is clean, hoses are not kinked, wax bag is not empty, or wax is contaminated.
	Striding belt/deck malfunction. The deck laminate worn through or the underside of striding belt glazed over (hard, glossy).	Replace belt and deck.
	Insufficient power source.	Plug treadmill into a dedicated 20 amp. circuit.
Rubbing sound from underneath machine	Foreign objects may be stuck underneath the machine.	Inspect underneath striding belt and machine. Remove any debris or objects that may cause interference with the treadmill.
	Tinsel is installed incorrectly.	Reposition tinsel on the outside of the striding belt.
	Insufficient power source.	Plug treadmill into a dedicated amp circuit.
Display does not illuminate when machine is powered on	Loose 10 pin connection at display console or wax/lift control board.	Check all electrical connections for proper attachment.  Contact Life Fitness Customer Support Services*.

\* See Section 6.7 "How to Obtain Product Service" for contact information.

## TROUBLESHOOTING THE TREADMILL (CONTINUED)

Malfunction	Probable Cause	Corrective Action
Unit resets randomly or pauses	Insufficient power source.	Plug treadmill into a dedicated 20 amp circuit.
	Damaged ground prong on line cord.	Replace line cord.
	Line cord improperly seated in electrical outlet.	Inspect power connection at electrical outlet and at machine for proper contact.
	Emergency stop magnet not engaged.	Re-engage the emergency stop magnet.
	Towel or other item may be making contact with stop switch while user is running.	Move all possible obstructions off display console and handlebar.
	Towel or other item may be covering the Smart Stop Sensor.	Move all possible obstructions off display console and handlebar.
	Stop switch is activated with very light pressure or returns slowly after being pressed.	Contact Life Fitness Customer Support Services*.
	Stop switch cable not making proper contact.	Contact Life Fitness Customer Support Services*.
	Pinched main wire harness.	Contact Life Fitness Customer Support Services*.
	Open ground path.	Contact Life Fitness Customer Support Services*.
	Inspect Smart Stop system.	Contact Life Fitness Customer Support Services*.

\* See Section 6.7 "How to Obtain Product Service" for contact information.

## 6.3 TROUBLESHOOTING THE OPTIONAL HEART RATE CHEST STRAP

### HEART RATE READING IS ERRATIC OR ABSENT ENTIRELY

Malfunction	Probable Cause	Corrective Action
Heart rate reading is erratic or absent entirely	Belt transmitter electrodes are not wet enough to pick up accurate heart rate readings.	Wet the belt transmitter electrodes (see section 3.2).
	Belt transmitter electrodes are not laying flat against the skin.	Ensure the belt transmitter electrodes are laying flat against the skin (see section 3.2).
	Belt transmitter needs cleaning.	Wash the belt transmitter with mild soap and water.
	Belt transmitter is not within 3 feet (one meter) of the heart rate receiver.	Make sure the chest strap transmitter is within three feet (one meter) of the heart rate receiver.
	Chest strap battery is depleted.	Contact Life Fitness Customer Support Services* for instructions on how to have the chest strap replaced.
Abnormally elevated heart rate readings	Electromagnetic interference from television sets and/or antennas.	Move the treadmill a few inches away from the probable cause, or move the probable cause a few inches away from the treadmill, until the heart rate readings are accurate.
	Electromagnetic interference from cell phones.	
	Electromagnetic interference from computers.	
	Electromagnetic interference from cars.	
	Electromagnetic interference from high voltage power lines.	
	Electromagnetic interference from motor driven exercise equipment.	
	Electromagnetic interference from another heart rate transmitter within three feet (one meter).	

\* See Section 6.7 "How to Obtain Product Service" for contact information.

## 6.5 HOW TO ADJUST AND TENSION THE STRIDING BELT

Do not move treadmill or place hands under treadmill while it is plugged into an electrical outlet!

### THE BELT TENSIONING BOLTS

A 5/16-inch hex key wrench is required for this task. The Life Fitness Treadmill has access holes in the rear roller guards which allow access to the tensioning bolts. These tensioning bolts make it possible to adjust the tracking and centering of the striding belt (A) without removing the guards.

**NOTE:** It is extremely important that the treadmill be correctly leveled prior to any tracking adjustments. An unstable unit may cause striding belt misalignment. See the topic titled "How To Stabilize the Life Fitness Treadmill" in the Section 1.2, titled Set Up, prior to attempting any rear roller adjustments.

Before proceeding, it is helpful to visualize the REAR ROLLER (B) pivot point (C). Each adjustment made to one side of the ROLLER must be met with an equal and opposite adjustment (D) to the other side of the ROLLER to maintain an ideal belt tension at the pivot point.

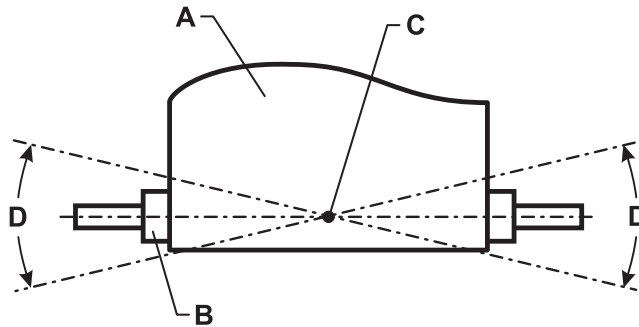

### TRACKING (CENTERING) A STRIDING BELT

Two people are needed to perform this procedure.

- 1 Locate the two access holes to the belt tensioning bolts on each of the rear roller guards.
- 2 One person stands on the side rails of the treadmill and straddles the belt. This person presses the MANUAL workout and sets the belt speed to 4.0 MPH (6.4 KPH).
- 3 If the striding belt has moved to the right, the second person turns the right tension bolt a quarter-turn clockwise and then turns the left tension bolt a quarter-turn counter-clockwise to make the striding belt track back to the center of the roller.

If the striding belt has moved to the left, turn the left tension bolt a quarter-turn clockwise and then turn the right tension bolt a quarter-turn counter-clockwise to make the striding belt track back to the center of the roller.

- 4 Repeat the adjustments until the striding belt appears centered. Allow the machine to continue running for several minutes to observe if tracking remains stabilized.

**NOTE:** Do not exceed one full turn of the adjusting screws in either direction. If after one full turn the belt does not track properly, contact Customer Support Services. The phone numbers are listed in Section 6.7, titled How to Obtain Product Service.

## TENSIONING AN EXISTING STRIDING BELT

- 1 Enter the Manual workout and operate the treadmill for five minutes at 5.0 MPH (8.0 KPH).  
**NOTE: DO NOT RUN OR WALK ON BELT.**
- 2 Reduce the speed to 2.0 MPH (3.2 KPH). Walk on the treadmill. Tightly grip the handrails and apply force with feet on the striding belt near the motor cover against the moving belt direction. If the belt slips, continue to Step 3. If it does not slip, the tension is correct.
- 3 Using the STOP key, stop the treadmill. Turn the belt tensioning bolts a quarter-turn clockwise for each side.
- 4 Repeat STEPS 2 and 3 until the belt no longer slips. Do not exceed one full turn (four quarter turns) per side when adjusting the belt tensioning bolts.
- 5 Enter the MANUAL workout and operate the treadmill at 2.0 MPH (3.2 KPH) check to insure proper tracking (See Section 6.5 *“How to Adjust and Tension the Striding Belt”*). If the striding belt drifts to the left or right see the topic titled *Tracking (Centering) an Existing or New Striding Belt* on the previous page.

Do not over-tighten the tensioning bolts while making belt adjustments. Over-tightening of bolts may over stretch and damage the striding belt or roller bearings. Do not exceed one full turn of either bolt in either direction.

## 6.6 CLEANING THE WAX NOZZLE

The MESSAGE CENTER periodically displays a wax reminder message, if the WAX REMINDER setting is enabled in the MANAGER'S CONFIGURATION. When this message appears, take the following steps:

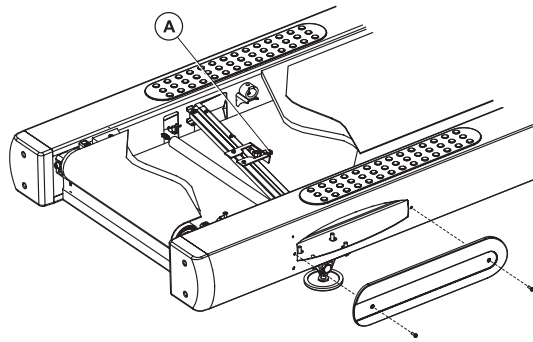

- A. Remove panel on right side to access nozzle (A).
- B. Make sure that the unit is off, and the electrical plug has been removed from the wall.
- C. Using a Phillips head screwdriver remove the two screws holding the right access panel in place.
- D. Carefully reach inside and while gently pushing the nozzle (A) into its brass holder body (C), rotate the nozzle one-quarter turn clockwise. Make note of the orientation of the two flat surfaces on the top and bottom of the nozzle. When the nozzle is replaced after cleaning, the flats must be on the top and bottom for nozzle to be correctly replaced.

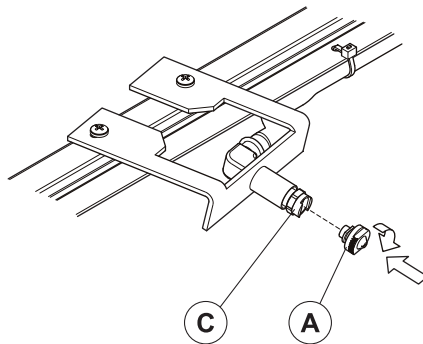

- E. Place the nozzle in a container of hot water and let it sit for 10 minutes. Afterward, carefully remove the nozzle.



**CAUTION: If necessary, scrub with a medium soft bristle brush until there is no further wax visible on the outside or inside of the nozzle.**

- F. Dry the nozzle with a lint-free towel and re-insert with a quarter-turn counterclockwise.

## 6.7 HOW TO OBTAIN PRODUCT SERVICE

1. Verify the symptom and review the operating instructions. The problem may be unfamiliarity with the product and its features and workouts.
2. Locate and write down the serial number of the unit, which is located on a plate near the power switch.
3. Contact the nearest Life Fitness Customer Support Services group:

For Product Service within  
the United States and Canada:

Telephone: (+1) 847.451.0036  
FAX: (+1) 847.288.3702  
Toll-free telephone: 800.351.3737

For Product Service Internationally:

*Life Fitness Europe GmbH (Germany)*  
Telephone: (+49) 089.317.751.66  
FAX: (+49) 089.317.751.38

*Life Fitness (UK) LTD*  
Telephone: (+44) 1353.665.507  
FAX: (+44) 1353.666.719

*Life Fitness Atlantic BV (Europe, Middle  
East & Africa, except local LF offices)*  
*Life Fitness Benelux*  
Telephone: +31 180.646.666  
FAX: +31 180.646.699

*Life Fitness Italia S.R.L.*  
Telephone: 800.438.836  
FAX: (+39) 0457.238.197

*Life Fitness Austria Vertriebs GmbH*  
Telephone: (+43) 1615.7198  
FAX: (+43) 1615.7198.20

*Life Fitness Asia Pacific Ltd (Asia &  
Australia, except local LF offices)*  
Telephone: (+852) 2891.6677  
FAX: (+852) 2575.6001

*Life Fitness Latin America  
and Caribbean*  
Telephone: (+1) 847.288.3964  
FAX: (+1) 847 288.3886

*Life Fitness Brazil*  
Telephone: (+55) 11.4193.8282  
FAX: (+55) 11.4193.8283

*Life Fitness Japan*  
Telephone: (+81) 3.3359.4309  
FAX: (+81) 3.3359.4307

*Life Fitness Iberia (Spain)*  
Telephone: (+34) 93.672.4660  
FAX: (+34) 93.672.4670

# 7 SPECIFICATIONS

## 7.1 LIFE FITNESS 93T TREADMILL SPECIFICATIONS

Designed use:	Heavy/Commercial
Maximum user weight:	400 pounds / 181 kilograms
Speed range:	0.5 - 10.0 MPH (0.8 - 16 KPH) in 0.1 increments for U.S. 0.5 - 12.0 MPH (0.8 - 20 KPH) in 0.1 for international
Elevation range:	0%-15% (in 0.1% increments)
Drive train:	AC motor with MagnaDrive™ motor controller
Motor type:	Variable Speed AC
Motor size:	4.0 HP continuous duty
Power requirements:	120 volt, 20 amp (U.S.). See Electrical Requirements for requirements outside the United States.
Rollers:	3.5 inch / 9 centimeter diameter, precision-crowned, front and back
Striding Belt:	60" Length x 20" Width (152 cm Length x 51 cm Width), multi-ply
Waxing system:	Patented Everwax automatic wax lubrication system
Deck type:	3/4" medium density reversible fiberboard
Shock Absorbtion System:	Patented FlexDeck® Shock Absorption System with Lifefrings™
Ergo™ Front Handrail:	Ergonomically shaped, painted steel
Side handrails:	26" (66 cm) long, flared and cantilevered
Stop systems:	Red and Yellow magnetic lanyard emergency stop system and Session Stop Push Switch raised and prominently positioned
Workouts:	Fat Burn, Cardio, Hill, Random, Manual and Fit Test
Levels:	20 (Hill and Random workouts)
Heart rate monitoring system:	Polar® telemetry compatible heart rate monitoring system
Console displays:	Elapsed time, total distance, total calories burned, Watts, METS, calories burned per hour, speed, incline, heart rate, pace, distance climbed, Profile Window
Ports (2):	Type RJ45, interchangeable Network ready connection and Fitness Entertainment port (power supply)

### PHYSICAL DIMENSIONS:

Length:	83 inches / 211 centimeters
Width:	37 inches / 94 centimeters
Height:	63.5 inches / 161 centimeters
Weight:	425 pounds / 193 kilograms
Step-Up Height	11" / 28 centimeters

### SHIPPING DIMENSIONS:

Length:	86.25 inches / 219 centimeters
Width:	42.5 inches / 108 centimeters
Height:	26.5 inches / 67 centimeters
Weight:	500 pounds / 227 kilograms



M051-00K58-B081

**Life Fitness World Headquarters**  
10601 W. Belmont Avenue  
Franklin Park, IL 60131