

93X, 90X Total Body Trainer
operation manual



LifeFitness

CORPORATE HEADQUARTERS

10601 West Belmont Avenue
Franklin Park, Illinois 60131 • U.S.A.
847.288.3300 • FAX: 847.288.3703
800.735.3867 (Toll-free within U.S.A., Canada)

INTERNATIONAL OFFICES

LIFE FITNESS ASIA PACIFIC LTD

Room 2610, Miramar Tower
132 Nathan Road
Tsimshatsui, Kowloon
HONG KONG
Telephone: (+852) 2891.6677
FAX: (+852) 2575.6001

LIFE FITNESS ATLANTIC BV

LIFE FITNESS BENELUX

Bijdorpplein 25-31
2992 LB Barendrecht
THE NETHERLANDS
Telephone: (+31) 180.646.666
FAX: (+31) 180.646.699

LIFE FITNESS DO BRAZIL

Av. Dr. Dib Sauaia Neto 1478
Alphaville, Barueri, SP
06465-140
BRAZIL
Telephone (+55) 11.4193.8282
FAX: (+55) 11.4193.8283

LIFE FITNESS AUSTRIA

Vertriebs GmbH
Hintschiggasse 1
1100 Vienna
AUSTRIA
Telephone: (+43) 1.61 57 198
FAX: (+43) 1.61 57 198.20

LIFE FITNESS IBERIA

Pol. Ind. Molí dels Frares. c/C, nº 12
08620 Sant Vicenç dels Horts (Barcelona)
España
Telephone: (+34) 93.672.4660
FAX: (+34) 93.672.4670

LIFE FITNESS EUROPE GMBH

Siemensstrasse 3
85716 Unterschleissheim
GERMANY
Telephone: (+49) 89.31 77 51.0
FAX: (+49) 89.31 77 51.99

LIFE FITNESS ITALIA S.R.L.

Via Elvas 92
39042 Bressanone (BZ)
ITALY
Telephone: (+39) 0472.835 470
FAX: (+39) 0472.833 150

LIFE FITNESS LATIN AMERICA and CARIBBEAN

10601 West Belmont Avenue
Franklin Park, Illinois 60131
U.S.A.
Telephone: (+1) 847.288.3300
FAX:(+1) 847.288.3762

LIFE FITNESS UK LTD

Queen Adelaide
Ely, Cambs CB7 4UB
UNITED KINGDOM
Telephone: (+44) 1.353.666 017
FAX: (+44) 1.353.666 018

LIFE FITNESS JAPAN

Nippon Brunswick Bldg., #8F
5-27-7 Sendagaya
Shibuya-Ku, Tokyo
Japan 151-0051
Telephone: (+81) 3.3359.4309
FAX: (+81) 3.3359.4307

Before using this product, it is essential that this ENTIRE operation manual and ALL installation instructions be read.

This will help in setting up the equipment quickly and in instructing others on how to use it correctly and safely.

Avant toute utilisation de ce produit, il est indispensable de lire ce manuel d'utilisation dans son INTÉGRALITÉ, ainsi que TOUTES les instructions d'installations.

Ce manuel explique comment installer l'équipement et comment l'utiliser correctement et sans danger.

FCC Warning - Possible Radio / Television Interference

NOTE: *This equipment has been tested and found to comply with the limits for a Class A digital device, pursuant to part 15 of the FCC rules. These limits are designed to provide reasonable protection against harmful interference when the equipment is operated in a commercial environment. This equipment generates, uses and can radiate radio frequency energy, and if not installed and used in accordance with the operation manual, may cause harmful interference to radio communications. Operation of this equipment in a residential area is likely to cause harmful interference in which case the user will be required to correct the interference at his own expense.*

Class S (Studio): Professional and / or commercial use.



CAUTION: Any changes or modifications to this equipment could void the product warranty.



MISE EN GARDE: Tout changement et toute modification de ce matériel peut annuler la garantie du produit.

Any service, other than cleaning or user maintenance, must be performed by an authorized service representative. There are no user serviceable parts.

TABLE OF CONTENTS

Section	Description	Page
1.	Getting Started	5
1.1	Important Safety Instructions	5
1.2	Setup	7
	Where to Place the Life Fitness® Fit Stride Total Body Trainer // How to Stabilize the Life Fitness Fit Stride Total Body Trainer // Check for Power // Fitness and Entertainment Networking	
2.	The Display Console	8
2.1	Display Console Overview	8
2.2	Display Console Descriptions	8
2.3	The Accessory Tray / Reading Rack	11
3.	Heart Rate Zone Training Exercise	12
3.1	Why Heart Rate Zone Training Exercise	12
3.2	Heart Rate Monitoring	13
	The Polar® Telemetry Heart Rate Monitoring Chest Strap	
4.	The Workouts	14
4.1	Workout Overviews	14
4.2	Using the Workouts	15
	To Begin a Workout // Selecting and Using Quick Start // Selecting a Workout // Entering Weight // Entering Age // Entering Time // Selecting and Adjusting the Resistance Level // Selecting a Workout Mode // Switching Workouts “On-the-fly” // Pausing Workouts // Ending Workouts Early // Workout Setup Steps (chart)	
4.3	Workout Descriptions	19
	Quick Start // Manual // Random // Fat Burn // Cardio // Hill // Six Pre-set Workouts // Heart Rate Hill™ Workout // Heart Rate Interval™ Workout // Extreme Heart Rate™ Workout // Cross-Train Aerobics // Cross-Train Reverse	
5.	Optional Settings	26
5.1	Entering and Using the Optional Settings Feature	26
6.	Service And Technical Data	27
6.1	Preventive Maintenance Tips	27
6.2	Preventive Maintenance Schedule	28
6.3	Troubleshooting the Polar Heart Rate Chest Strap	28
	Heart Rate Reading Is Erratic, Absent Entirely, or Abnormally High	
6.4	How to Obtain Product Service	29
7.	Specifications	30
7.1	Life Fitness 93X Fit Stride Total Body Trainer Specifications	30
7.2	Life Fitness 90X Fit Stride Total Body Trainer Specifications	31

© 2003 Life Fitness, a division of Brunswick Corporation. All rights reserved. Life Fitness and Heart Rate Zone Training are registered trademarks of Brunswick Corporation. Fit Stride, Heart Rate Zone Training, Heart Rate Hill, Heart Rate Interval, and Extreme Heart Rate are trademarks of Brunswick Corporation. Polar is a registered trademark of Polar Electro, Inc. Cardio Theater is a registered trademark of the Cardio Theater Holdings. FitLinx is a registered trademark of the Integrated Fitness Corp. Any use of these trademarks, without the express written consent of Life Fitness or the corresponding companies is forbidden.

This Operation Manual describes the functions of the following products:

Life Fitness Fit Stride™ Total Body Trainers

93X, 90X

See "Specifications" page in this manual for product specific features.

Statement of Purpose: The Life Fitness Fit Stride Total Body Trainer is an exercise machine that combines low-impact elliptical pedaling with push/pull arm motion to provide an efficient, effective total body workout.



CAUTION: Health-related injuries may result from incorrect or excessive use of exercise equipment. Life Fitness STRONGLY recommends seeing a physician for a complete medical exam before undertaking an exercise program, particularly if the user has a family history of high blood pressure or heart disease, or is over the age of 45, or smokes, has high cholesterol, is obese, or has not exercised regularly in the past year.

If, at any time while exercising, the user experiences faintness, dizziness, pain, or shortness of breath, he or she must stop immediately.



MISE EN GARDE: Des problèmes de santé peuvent être causés par une utilisation incorrecte ou excessive de l'équipement. Life Fitness conseille VIVEMENT de consulter un médecin pour subir un examen médical complet avant de commencer tout programme d'exercice, et tout particulièrement si l'utilisateur a des antécédents familiaux d'hypertension ou de troubles cardiaques, ou s'il a plus de 45 ans, s'il fume, s'il a du cholestérol, s'il est obèse ou n'a pas fait d'exercice régulièrement depuis un an.

Si, pendant l'utilisation de l'appareil, l'utilisateur ressent un malaise, des vertiges, des douleurs ou des difficultés à respirer, il doit cesser immédiatement.

1 GETTING STARTED

1.1 IMPORTANT SAFETY INSTRUCTIONS



SAFETY WARNING: The safety of the product can be maintained only if it is examined regularly for damage and wear. See Preventive Maintenance section for details.

- If this Life Fitness product does not function properly after it has been dropped, damaged, or even partially immersed in water, contact Life Fitness Customer Support Services for assistance.
- Always follow the console instructions for proper operation.
- Close supervision is necessary when used by children, invalids or disabled persons.
- Do not use this product outdoors, near swimming pools or in areas of high humidity.
- Never operate a Life Fitness product with the air openings blocked. Keep air openings free of lint, hair or any obstructing material.
- Never insert objects into any opening in this product. If an object should drop inside, carefully retrieve it. If the item cannot be reached, contact Life Fitness Customer Support Services.
- Never place liquids of any type directly on the unit, except in the accessory tray water bottle holder. Containers with lids are recommended.
- Wear shoes with rubber or high-traction soles. Do not use shoes with heels, leather soles, cleats or spikes. Make sure no stones are embedded in the soles.
- Keep all loose clothing, shoelaces and towels away from moving parts.
- Do not use this product in bare feet.
- Do not tip the unit on its side during operation.
- Keep the area around the Life Fitness product clear of any obstructions, including walls and furniture. Ensure that there is at least one foot of clearance in front of the Life Fitness Fit Stride Total Body Trainer.
- Use caution when mounting or dismounting the Life Fitness Fit Stride Total Body Trainer. Use the stationary handlebar whenever additional stability is required. While exercising, hold onto the moving arms.
- Never use the Life Fitness Fit Stride Total Body Trainer while facing backward.
- Do not stand or sit on pedal lever covers or motor housing.

SAVE THESE INSTRUCTIONS FOR FUTURE REFERENCE.

1 POINT DE DÉPART

1.1 CONSIGNES DE SÉCURITÉ IMPORTANTES



CONSIGNE DE SÉCURITÉ : pour un emploi sûr, le produit doit être inspecté régulièrement afin de s'assurer qu'il n'est pas usé ni endommagé. Consultez la section de Maintenance préventive pour obtenir de plus amples informations.

- Si l'appareil Life Fitness ne fonctionne pas correctement après avoir subi une chute, des dommages ou une immersion même partielle dans l'eau, contactez le service d'assistance clientèle de Life Fitness.
- Pour un fonctionnement correct, suivez toujours les instructions de la console.
- Une surveillance étroite est nécessaire en cas d'utilisation par des enfants, des personnes invalides ou handicapées.
- N'utilisez pas ce produit à l'extérieur, près d'une piscine ou dans endroits très humides.
- Ne faites jamais fonctionner de produit Life Fitness dont les bouches d'aération seraient bloquées. Maintenez-les exemptes de peluches, de cheveux ou de toute obstruction.
- N'insérez jamais d'objet dans les ouvertures de cet appareil. Si un objet tombe dedans, coupez l'alimentation électrique, débranchez le cordon de la prise et récupérez-le avec précaution. Si vous ne pouvez pas l'atteindre, consultez le service après-vente de Life Fitness.
- Ne placez jamais de liquides d'aucune sorte directement sur l'appareil, sauf si vous disposez d'un support ou d'un plateau pour accessoires. Il est recommandé d'utiliser des conteneurs munis d'un couvercle.
- Portez des chaussures avec semelles en caoutchouc ou antidérapantes. N'utilisez pas de chaussures à talons, de semelles en cuir ou à crampons. Assurez-vous qu'aucun caillou ne s'est incrusté dans les semelles.
- Maintenez les vêtements lâches, les lacets et les serviettes à l'écart des pièces en mouvement.
- N'utilisez pas cet appareil sans chaussures.
- Ne faites pas basculer l'appareil sur le côté tandis qu'il fonctionne.
- Maintenez la zone autour du produit Life Fitness exempte d'obstructions, y compris de murs et de meubles. Veillez à laisser au moins 30 cm d'espace autour du Life Fitness Fit Stride Total Body Trainer.
- Procédez avec précaution lors du montage ou du démontage de la machine. Utilisez la barre fixe pour renforcer votre stabilité. Pendant les exercices, saisissez les bras mobiles.
- N'utilisez jamais cet appareil en vous tournant vers l'arrière.

CONSERVEZ CES INSTRUCTIONS POUR USAGE ULTÉRIEUR.

1.2 SETUP

Read the Operation Manual before setting up the Life Fitness Fit Stride Total Body Trainer.

WHERE TO PLACE THE LIFE FITNESS FIT STRIDE TOTAL BODY TRAINER

Following all safety instructions in Section 1.1, move the Cross-trainer to the location in which it will be used. See Section 7, titled *Specifications*, for the dimensions of the footprint. Allow one foot of clearance in front of the Cross-trainer to allow for movement of the pedal levers. It should be easy to mount the Cross-trainer from the side.

HOW TO STABILIZE THE LIFE FITNESS FIT STRIDE TOTAL BODY TRAINER

After placing the Life Fitness Fit Stride Total Body Trainer in position, check the unit's stability by attempting to rock it. Any slight rocking indicates that the unit must be leveled. Check the front stabilizing feet to determine which foot does not rest fully on the floor. Rotate the foot counter-clockwise to lower it. Recheck the stability and adjust again as needed until the Life Fitness Fit Stride Total Body Trainer is stable and no longer rocks. **Lock the adjustment into position by tightening the jam nut against the stabilizer bar with an open end 17mm wrench.**

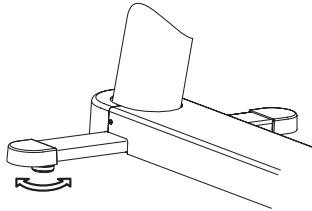

CHECK FOR POWER

The Life Fitness Fit Stride Total Body Trainer console is powered by a rechargeable 6-volt battery. Check the battery by pressing the START key. The console should light up, and the MESSAGE CENTER should display a prompt to set up a workout. If this does not occur, mount the Life Fitness Fit Stride Total Body Trainer and begin pedaling. The console should then light up, making it possible to program a workout. Pedal for 10 to 20 minutes at 1.5 mph (2.4 km/h) or faster during a workout to charge the battery. Afterwards, the pedal action during workouts keeps the battery charged. If the console still does not light, contact Life Fitness Customer Service. See section 6.5, titled *How to Obtain Product Service*, for more information.

FITNESS AND ENTERTAINMENT NETWORKING

The Life Fitness Fit Stride Total Body Trainer may be connected via CSAFE protocol to a fitness entertainment system and/or a fitness network, such as the FitLinxx™ interactive fitness network. Contact Life Fitness Customer Support Services to purchase networking kits. See section 6.5, titled *How to Obtain Product Service*, for more information.

- **Fitness network:** The network connection enables the console to upload user workout statistics to a fitness network database or to download remotely stored information, such as a pre-set workout program. See Section 4.2, titled *Using the Workouts*, for information on logging onto a network.
- **Entertainment:** The network connection enables the console to power a third-party receiver for use with a service such as the Cardio Theater® entertainment system or the BroadcastVision™ entertainment system.

2 THE DISPLAY CONSOLE

2.1 DISPLAY CONSOLE OVERVIEW

The computerized display console on the Life Fitness Fit Stride Total Body Trainer allows the user to tailor a workout to personal fitness abilities and goals and to monitor progress. With this easy-to-use console, the user can track fitness improvement from one workout to the next.

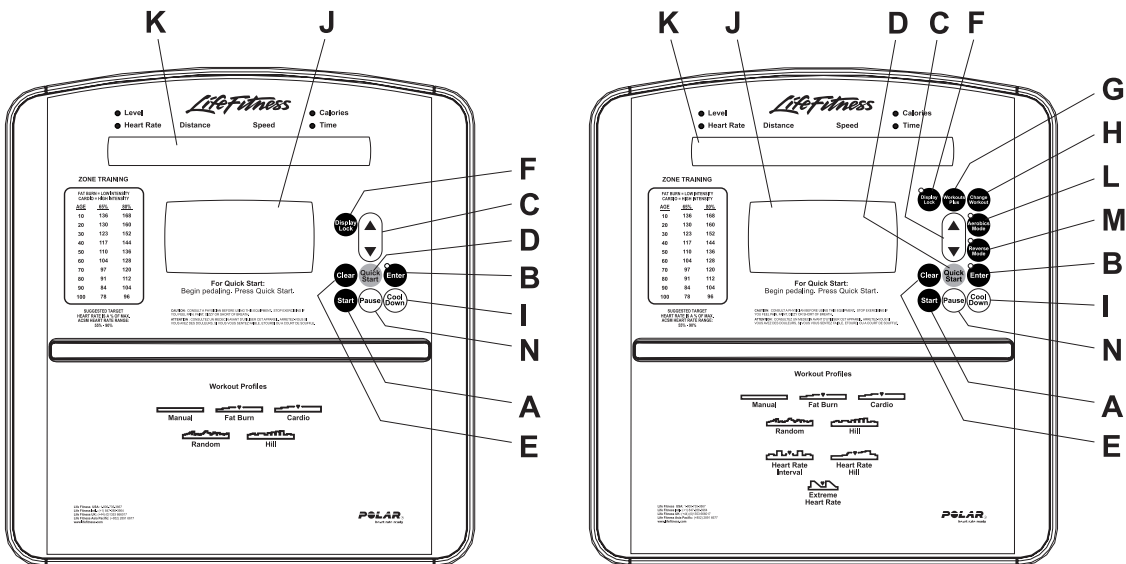

2.2 DISPLAY CONSOLE DESCRIPTIONS

This section lists and describes the functions for the keys and display windows on the Life Fitness Fit Stride Total Body Trainer console. See Section 4, titled *The Workouts*, for detailed information on using the console to set up workouts.

- A START:** Press this key to activate the console for programming a new workout. The activated console lights up and displays “SELECT WORKOUT USING ARROW KEYS OR PRESS QUICK START”. If no key is pressed for 15 seconds, and the user stops pedaling, the console shuts down again.

NOTE: The AutoStart feature also activates the console when the user steps on the pedals and begins pedaling.

- B** ENTER: Press this key after entering each value, such as weight or workout time, when prompted by console display messages.
- C** ARROW keys: Use the UP and DOWN ARROW keys to change workout parameters displayed on the console, such as length of workout, weight, age, target heart rate, and intensity level. Pressing these keys during a **FAT BURN**, **CARDIO**, **HEART RATE HILL**, **HEART RATE INTERVAL**, or **EXTREME HEART RATE** workout increases or decreases the target heart rate*.
- D** QUICK START: Press this key to begin a manual workout immediately, without having to select a workout program. Once the workout is in progress, use the ARROW KEYS to change the intensity level.
- E** CLEAR: When programming a workout, press this key, to clear incorrect data, such as weight or age, before pressing the ENTER key. Pressing CLEAR during a workout stops it immediately, at which point the MESSAGE CENTER displays a summary of the workout, including total time elapsed, total distance traveled, and total calories burned. Pressing CLEAR a second time causes the MESSAGE CENTER to prompt the user for a new workout setup.
- F** DISPLAY LOCK: During a workout, the MESSAGE CENTER alternately displays the number of CALORIES burned and the amount of TIME elapsed. Pressing the DISPLAY LOCK key when the MESSAGE CENTER displays either statistic forces the MESSAGE CENTER to display that statistic continuously throughout the workout. Pressing DISPLAY LOCK again allows the MESSAGE CENTER to resume toggling between both statistics.
- G** WORKOUTS PLUS (93X only): Press this key to select a customized workout designed by a fitness club trainer or staff member. See Section 5, titled *Internal Settings* for information on designing custom workouts. The following workouts may be accessed with this key:
- **CROSS-TRAIN AEROBICS**
 - **CROSS-TRAIN REVERSE**
 - **AROUND THE WORLD**
 - **KILIMANJARO**
 - **INTERVAL**
 - **CASCADES**
 - **SPEED TRAINING**
 - **FOOTHILLS**
- H** CHANGE WORKOUT (93X only): Press this key to switch to another workout while a workout is in progress.
- I** COOLDOWN: workouts end automatically in a Cooldown mode, which lowers the intensity level. Press the COOLDOWN key at any desired point during a workout to go immediately into Cooldown mode. In this phase of a workout the body begins to remove lactic acid and other accumulated by-products of exercise, which build up in muscles during a workout and contribute to muscle soreness. The console automatically adjusts each workout's Cooldown level according to the individual user's performance. Each time the user presses the COOLDOWN key, the Cooldown duration shortens by one minute.
- J** WORKOUT PROFILE WINDOW: This window displays shapes, made of columns of lights, that represent the levels of intensity in a workout-in-progress. The height of the column is proportional to the level of the intensity.

* Target Heart Rate (THR) is a percentage of the theoretical maximum. For example, a 40-year-old user's THR for the **CARDIO** workout is 144. This workout targets 80 percent of the maximum, so the equation would be $(220-40) \cdot 80 = 144$.

During a **FAT BURN, CARDIO, HEART RATE HILL, HEART RATE INTERVAL, or EXTREME HEART RATE** workout, which requires the use of a Polar® heart rate chest strap, the WORKOUT PROFILE window displays a heart shape to request the user's heart rate signal. If the console does not detect a signal, the MESSAGE CENTER displays the prompt "NEED HEART RATE - USE TELEMETRY STRAP". If the console does not receive the signal within three minutes, the workout automatically is converted to a **MANUAL** workout.

K MESSAGE CENTER: This window displays step-by-step instructions for setting up a workout. During a workout, it displays statistics about the progress of the workout:

- **Level:** programmed intensity level. Toggles with **Heart Rate**.
- **Heart Rate:** the detected heart rate if the user is wearing the chest strap. Toggles with **Level**. If the on-board computer does not detect a heart rate, only **Level** is displayed throughout the workout.
- **Distance:** the total distance traveled in miles (or kilometers if enabled).
- **Speed:** the pedaling speed or rate in miles per hour (or kilometers per hour if enabled).
- **Calories:** the number of calories burned since beginning the workout. Toggles with **Time**.
- **Time:** time elapsed since the start of the workout. Toggles with **Calories**.

If programmed to do so, the MESSAGE CENTER displays any or all of these three values each time the intensity level changes during the workout:

- **Calories per Hour:** the rate of calories burned per hour.
- **Watts:** effort level in Watts. The Watt is a unit of power output or the expression of the mechanical rate of work.
- **METs:** effort level in METs. The MET is an expression of the rate of work for the human body at rest, or a metabolic equivalent; one MET is approximately equal to the metabolism of a person at rest.

See Chapter 5, titled *Internal Settings* for information about enabling the MESSAGE CENTER to display these additional settings.

L AEROBICS MODE (93X only): Press this key to activate a workout mode in which the MESSAGE CENTER displays prompts that vary the workload and emphasize different muscle groups during the workout. It can be used with any workout, except for Fat Burn, Cardio, Heart Rate Hill, Heart Rate Interval, or Extreme Heart Rate.

M REVERSE MODE (93X only): Press this key to activate a workout mode that alternates five minutes of forward motion with two minutes of reverse motion. It can be used with any workout, except for Fat Burn, Cardio, Heart Rate Hill, Heart Rate Interval, or Extreme Heart Rate.

N PAUSE: Press this key to pause the current workout. Continue the workout by pressing the PAUSE key again. For more information, see the topic titled *Pausing a Workout* in Section 4.2, titled *Using the Workouts*.

For more information about Aerobics Mode and Reverse Mode, see the topic *Using the Two Workout Modes* in Section 4.2, titled, the *Using the Workouts*.

2.3 THE ACCESSORY TRAY / READING RACK

The accessory tray (A), which is mounted near the base of the console, provides storage for items such as water bottles, personal stereos, and cell phones. Additionally, an integrated reading rack (B) for supporting a book or magazine is located at the base of the upper panel of the console. The tray is standard on the 93X model and optional on the 90X model. To order it, call Life Fitness Customer Support Services. See Section 6.4, titled *How to Obtain Product Service*.

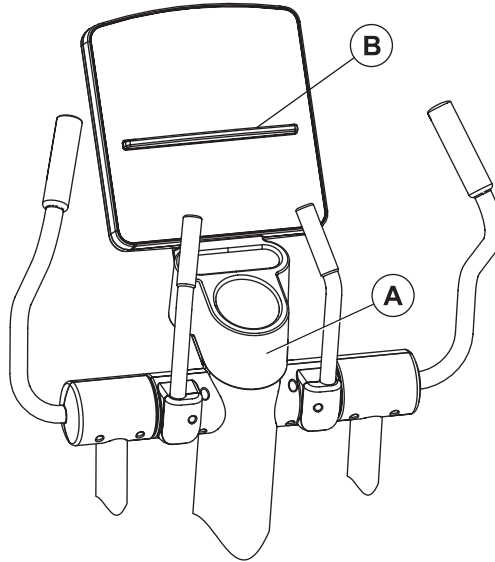

3 HEART RATE ZONE TRAINING EXERCISE

3.1 WHY HEART RATE ZONE TRAINING EXERCISE?

Research shows that maintaining a specific heart rate while exercising is the optimal way to monitor the intensity of a workout and to achieve maximum results. That is the idea behind the Life Fitness heart rate zone training approach to exercise.

Zone training identifies an exerciser's ideal heart rate range, or zone, for burning fat or increasing cardiovascular fitness. The values within the zone depend on the workout.

NOTE: Consulting a fitness trainer is recommended for defining specific fitness goals and designing a workout program.

ZONE TRAINING		
FAT BURN = LOW INTENSITY		
CARDIO = HIGH INTENSITY		
AGE	65%	80%
10	136	168
20	130	160
30	123	152
40	117	144
50	110	136
60	104	128
70	97	120
80	91	112
90	84	104
100	78	96

SUGGESTED TARGET
HEART RATE AS % OF MAX
ACSM HEART RATE RANGE:
55% - 90%

The Life Fitness Fit Stride Total Body Trainer features exclusive workouts designed to take full advantage of the benefits of heart rate zone training exercise: **FAT BURN**, **CARDIO**, **HEART RATE HILL** (93X only), **HEART RATE INTERVAL** (93X only), and **EXTREME HEART RATE** (93X only). For detailed information about the workouts, see Section 4, titled *The Workouts*.

During one of these workouts, wear the Polar® heart rate chest strap to enable the on-board computer to monitor the heart rate during a workout. The computer automatically adjusts the resistance level to maintain the target heart rate* based on the actual heart rate. To change the target heart rate during a workout, use the ARROW keys.

* Target Heart Rate (THR) is a percentage of the theoretical maximum. For example, a 40-year-old user's THR for the **CARDIO** workout is 144. This workout targets 80 percent of the maximum, so the equation would be $(220-40) \cdot 80 = 144$.

3.2 HEART RATE MONITORING

THE POLAR® TELEMETRY HEART RATE MONITORING CHEST STRAP

The Life Fitness Fit Stride Total Body Trainer is equipped with Polar® telemetry, a heart rate monitoring system in which electrodes, pressed against the skin, transfer heart rate signals to the console. These electrodes are attached to a chest strap that the user wears during the workout. The chest strap is optional. To order it, call Life Fitness Customer Support Services. See Section 6.4, titled *How to Obtain Product Service*.

See the diagram below for correct positioning of the strap. The electrodes (A), which are the two grooved surfaces on the underside of the strap, must remain wet to transmit accurately the electrical impulses of the heart back to the receiver. Moisten the electrodes. Then, secure the strap as high under the chest muscles as possible. The strap should be snug, but comfortable enough to allow for normal breathing.

The transmitter strap delivers an optimal heart rate reading when the electrodes are in direct contact with skin. However, it also functions properly through a thin layer of wet clothing.

If it becomes necessary to re-moisten the chest strap electrodes, grasp the center of the strap, pull it away from the chest to expose the two electrodes, and moisten them.

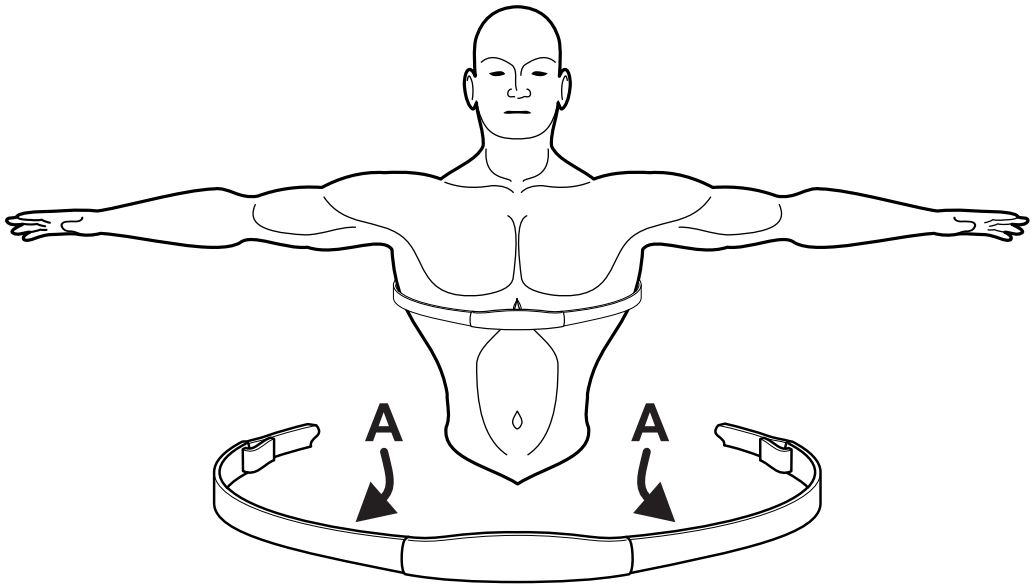

4 THE WORKOUTS

4.1 WORKOUT OVERVIEWS

This section lists the Life Fitness Fit Stride Total Body Trainer's pre-programmed workouts. For more detailed information, see Section 4.2, titled *Using the Workouts*. The following workouts are accessible via the ARROW keys.

QUICK START is the fastest way to begin exercising and bypasses the steps involved in selecting a specific workout program. After the QUICK START key is pressed, a constant-level workout begins. The intensity level does not change automatically.

MANUAL is a workout in which the intensity level does not change automatically.

RANDOM is an interval training workout of constantly changing intensity levels that occur in no regular pattern or progression.

FAT BURN is a low-intensity workout for burning the body's fat reserves. The user must wear a heart rate chest strap. The workout program automatically adjusts the intensity level, based on the actual heart rate, to maintain the rate at 65 percent of the theoretical maximum[†].

CARDIO is a higher intensity workout for more fit users, emphasizing cardiovascular benefits and maximum fat burning. The user must wear a heart rate chest strap. The workout program automatically adjusts the intensity level, based on the actual heart rate, to maintain the rate at 80 percent of the theoretical maximum.

HEART RATE HILL (93X only) takes the user through three different hills based on the target heart rate*. The user must wear a heart rate chest strap.

HEART RATE INTERVAL (93X only) alternates between a hill and a valley based on the target heart rate. The user must wear a heart rate chest strap.

EXTREME HEART RATE (93X only) alternates between two target heart rate goals as quickly as possible. The effect is similar to that of running sprints. The user must wear a heart rate chest strap.

CROSS-TRAIN AEROBICS (accessible via the WORKOUTS PLUS key on the 93X) simulates the experience of working with a personal trainer. The MESSAGE CENTER displays prompts at different times to emphasize pushing, pulling, total body, lower body, speed changes, and forward/reverse motion. This versatile workout promotes maximum cross-training benefits.

CROSS-TRAIN REVERSE (accessible via the WORKOUTS PLUS key on the 93X) continuously alternates five minutes of forward motion with two minutes of backward motion to cross-train different muscle groups.

HILL is an interval-training workout combining "hills" and "valleys" of different intensity levels, which is proven to provide effective, time-efficient cardiovascular results.

[†] Defined by the American College of Sports Medicine's "Guidelines for Exercise Testing and Prescription" as equal to 220 minus an individual's age.

* Target Heart Rate (THR) is a percentage of the theoretical maximum. For example, a 40-year-old user's THR for the **HEART RATE HILL** workout is 144. This workout targets 80 percent of the maximum, so the equation would be $(220-40) \cdot .80 = 144$.

The following workouts, available on the 93X model, are accessed by pressing the WORKOUTS PLUS key :

AROUND THE WORLD is an interval-training workout in which the hills resemble scenes of various geographical areas.

CASCADES is a two-peak workout in which intensity levels gradually increase and decrease.

FOOTHILLS is a rolling hill workout with low intensity levels.

INTERVAL is a Hill workout in which intensity levels rise and fall. The higher levels gradually incline toward a peak and then gradually decline.

KILIMANJARO is a Hill workout in which the intensity levels gradually incline toward one ultimate peak and then gradually decline.

SPEED TRAINING is a Hill workout in which the intensity level alternates between high and low levels very quickly to simulate a typical speed training workout.

CROSS-TRAIN AEROBICS (accessible via the ARROW keys on the 90X) simulates the experience of working with a personal trainer. The MESSAGE CENTER displays prompts at different times to emphasize pushing, pulling, total body, lower body, speed changes, and forward/reverse motion. This versatile workout promotes maximum cross-training benefits.

CROSS-TRAIN REVERSE (accessible via the ARROW keys on the 90X) continuously alternates five minutes of forward motion with two minutes of backward motion to cross-train different muscle groups.

4.2 USING THE WORKOUTS

This section provides detailed information on setting up and using workouts. For quick-reference setup steps, see the chart near the end of the section.

TO BEGIN A WORKOUT

To mount the Life Fitness Fit Stride Total Body Trainer, grasp the handles and carefully step on the pedals. To dismount, step off the pedals while still holding the handles. Then let go of the handles.

Without optional networking, press START or begin pedaling to activate the console. The MESSAGE CENTER displays, "SELECT WORKOUT USING ARROW KEYS OR PRESS QUICK START". If it displays a different message, press the CLEAR key twice in rapid succession.

With optional networking kit installed (93X only), press START or begin pedaling to activate the console. The MESSAGE CENTER displays, "SELECT WORKOUT USING ARROW KEYS OR ENTER ID USING ENTER KEY". Either select a workout as described below, or log on to the networked exercise database, and then select a workout. To log onto the network, use the ARROW keys to scroll in the user ID number.

SELECTING AND USING QUICK START

QUICK START is the fastest way to begin exercising and bypasses the steps of selecting a specific workout program. At the MESSAGE CENTER prompt to select a workout, press the QUICK START key. The workout begins at an intensity level that remains the same unless manually changed. After 12 seconds, the MESSAGE CENTER displays a prompt to enter weight, which the computer requires to calculate total calories.

SELECTING A WORKOUT

For **MANUAL**, **FAT BURN**, **CARDIO**, **RANDOM**, **HILL**, **HEART RATE HILL** (93X only), **HEART RATE INTERVAL** (93X only), and **EXTREME HEART RATE** (93X only): When prompted to select a workout, use the ARROW KEYS to scroll through the workout names as they appear in the MESSAGE CENTER. When the desired workout appears, press ENTER.

For **CROSS-TRAIN REVERSE** and **CROSS-TRAIN AEROBICS** (On the 93X model): When prompted by the MESSAGE CENTER to select a workout, press the WORKOUTS PLUS key. The MESSAGE CENTER then displays the name of one of the available workouts. Press ENTER to select the displayed workout or continue to press the WORKOUTS PLUS key to display each of the other options, and then press ENTER to select the desired workout.

For **CROSS-TRAIN REVERSE** and **CROSS-TRAIN AEROBICS** (On the 90X model): When prompted to select a workout, use the ARROW keys to scroll through the workout names as they appear in the MESSAGE CENTER. When the desired workout appears, press ENTER.

For **AROUND THE WORLD**, **FOOTHILLS**, **INTERVAL**, **KILIMANJARO**, **ROLLING HILLS**, and **SPEED TRAINING**: All of these workouts are available on the 93X model only. When prompted by the MESSAGE CENTER to select a workout, press the WORKOUTS PLUS key. The MESSAGE CENTER then displays the name of one of these workouts. Press ENTER to select the displayed workout or continue to press the WORKOUTS PLUS key to display each of the other options. Press ENTER to select the desired workout.

ENTERING WEIGHT

When prompted by the MESSAGE CENTER to enter weight, use the ARROW KEYS to increase or decrease the displayed weight to the correct value and press ENTER. The default weight is 150 pounds or 68 kilograms. The on-board computer calculates the number and rate of calories burned using the entered weight as well as the pedaling speed.

ENTERING AGE

When prompted by the MESSAGE CENTER to enter age, use the ARROW KEYS to increase or decrease the displayed age to the correct value and press ENTER.

Workout programs that set a target heart rate* zone first calculate the user's theoretical maximum heart rate[†] by subtracting the user's age from the number 220. The programs then calculate the target zone as a percentage of the theoretical maximum.

ENTERING TIME

When prompted by the MESSAGE CENTER to enter a time, use the ARROW KEYS to increase or decrease the displayed time to the desired value and press ENTER.

SELECTING AND ADJUSTING THE RESISTANCE LEVEL

When prompted by the MESSAGE CENTER, use the ARROW KEYS to increase or decrease the displayed intensity level or target heart rate to the desired value and press ENTER. Adjust the level as needed or desired during the workout.

[†] Defined by the American College of Sports Medicine's "Guidelines for Exercise Testing and Prescription" as equal to 220 minus an individual's age.

* Target Heart Rate (THR) is a percentage of the theoretical maximum. For example, a 40-year-old user's THR for the **CARDIO** workout is 144. This workout targets 80 percent of the maximum, so the equation would be $(220-40) \cdot 80 = 144$.

- **Resistance level:** The Life Fitness Fit Stride Total Body Trainer provides a selection of 25 resistance levels. The resistance level appears in the WORKOUT PROFILE window as rows of lights arranged in columns. Selecting a low intensity level at first is recommended. As physical conditioning improves, the levels can increase.
- **Target heart rate*:** Programs that calculate a target heart rate base this number on the age of the user and the type of workout. The user accepts or adjusts the rate when setting up the workout. During the workout itself, the program reads the heart rate, which is transmitted via the chest strap; it uses this data to adjust the resistance. Manually raising the rate increases the intensity of the cardiovascular exercise.

SELECTING A WORKOUT MODE (93X ONLY)

Two workout mode options on the Life Fitness Fit Stride Total Body Trainer feature alternate ways to vary workouts.

- **Aerobics Mode:** This workout mode simulates the experience of working out with a trainer. Throughout the workout, the MESSAGE CENTER displays prompts to vary the workload and emphasize different muscle groups, such as upper- and lower-body. This feature can be used with any workout, except for the Fat Burn, Cardio, Heart Rate Hill, Heart Rate Interval, or Extreme Heart Rate workouts. To select it, press AEROBICS MODE key.
- **Reverse Mode:** This workout mode continuously alternates five minutes of forward motion with two minutes of reverse motion, to exercise different leg muscles. This feature can be used with any workout, except for the Fat Burn, Cardio, Heart Rate Hill, Heart Rate Interval, or Extreme Heart Rate workouts. To select it, press the REVERSE MODE key.

SWITCHING WORKOUTS “ON-THE-FLY” (93X ONLY)

It is possible, during a workout, to switch to another workout program. After a switch, the console retains all the progress information about the workout since its beginning. To change workouts “on-the-fly,” press CHANGE WORKOUT key and then select a new workout. This feature is available for all workouts, except **AROUND THE WORLD, KILIMANJARO, INTERVAL, CASCADES, SPEED TRAINING,** and **FOOTHILLS.**

PAUSING WORKOUTS

To pause a workout, simply stop pedaling. To continue the workout, resume pedaling. The pause duration lasts 60 seconds, after which the console automatically shuts down.

ENDING WORKOUTS EARLY

To end a workout before the pre-set duration expires, press CLEAR once. The MESSAGE CENTER then displays a workout summary, which includes the distance travelled, the total calories burned, and other statistics. Press CLEAR a second time and the MESSAGE CENTER displays “SELECT WORKOUT USING ARROW KEYS OR PRESS QUICK START” for a new workout.

* Target Heart Rate (THR) is a percentage of the theoretical maximum. For example, a 40-year-old user's THR for the **CARDIO** workout is 144. This workout targets 80 percent of the maximum, so the equation would be $(220-40) \cdot 80 = 144$.

LIFE FITNESS FIT STRIDE TOTAL BODY TRAINER WORKOUT SETUP STEPS

QUICK START

Press QUICK START
Begin workout

MANUAL

Select MANUAL
Enter weight
Enter time
Select level
Begin workout

RANDOM

Select RANDOM
Enter weight
Enter time
Select level
Begin workout

FAT BURN*

Select FAT BURN
Enter weight
Enter time
Enter age
Accept THR**
Begin workout

CARDIO*

Select CARDIO
Enter weight
Enter time
Enter age
Accept THR
Begin workout

HEART RATE HILL*

(93X only)
Select HEART RATE
HILL
Enter weight
Enter time
Enter age
Accept THR
Begin workout

HEART RATE INTERVAL*

(93X only)
Select HEART RATE
INTERVAL
Enter weight
Enter time
Enter age
Accept THR
Begin workout

EXTREME HEART RATE*

(93X only)
Select EXTREME
HEART RATE
Enter weight
Enter time
Enter age
Accept THR
Begin workout

CROSS-TRAIN

AEROBICS

On 93X, press WORK-
OUTS PLUS repeat-
edly until X-TRAIN
AEROBICS appears
(on 90X, use ARROW
keys to select X-
TRAIN AEROBICS);
press ENTER
Enter weight
Enter time
Select level
Begin workout

CROSS-TRAIN REVERSE

On 93X, press WORK-
OUTS PLUS repeat-
edly until X-TRAIN
REVERSE appears
(on 90X, use ARROW
keys to select X-
TRAIN REVERSE);
press ENTER

HILL

Select HILL
Enter weight
Enter time
Select level
Begin workout

AROUND THE WORLD

(93X only)
Press WORKOUTS
PLUS repeatedly until
AROUND THE
WORLD Appears;
press ENTER
Enter weight
Enter time
Select level
Begin workout

CASCADES (93X only)

Press WORKOUTS
PLUS repeatedly until
CASCADES appears;
press ENTER
Enter weight
Enter time
Select level
Begin workout

FOOTHILLS (93X only)

Press WORKOUTS
PLUS repeatedly until
FOOTHILLS appears;
press ENTER
Enter weight
Enter time
Select level
Begin workout

KILIMANJARO (93X only)

Press WORKOUTS
PLUS repeatedly until
KILIMANJARO
appears; press
ENTER
Enter weight
Enter time
Select level
Begin workout

INTERVAL (93X only)

Press WORKOUTS
PLUS repeatedly until
INTERVAL appears;
press ENTER
Enter weight
Enter time
Select level
Begin workout

SPEED TRAINING

(93X only)
Press WORKOUTS
PLUS repeatedly until
SPEED TRAINING
appears; press
ENTER
Enter weight
Enter time
Select level
Begin workout

* This workout requires the user to wear the telemetry chest strap.

** Target Heart Rate (THR) is a percentage of the theoretical maximum. For example, a 40-year-old user's THR for the **FAT BURN** workout is 117. This workout targets 65 percent of the maximum, so the equation would be $(220-40) \cdot 65 = 117$. When the MESSAGE CENTER displays a Target Heart Rate, either accept it by pressing ENTER, or change the value with the ARROW keys, and then press ENTER.

4.3 WORKOUT DESCRIPTIONS

QUICK START

QUICK START is the fastest way to begin exercising and bypasses the steps of selecting a specific workout program. The intensity level for the workout is set automatically and remains the same unless manually changed. To change the level, press the UP or DOWN ARROW keys to enter a higher or lower level number. After the workout has been in progress for 12 seconds, the MESSAGE CENTER displays “ENTER WEIGHT”, which the computer requires to calculate total calories. Using the ARROW KEYS, increase or decrease the displayed weight to the correct value.

MANUAL

The **MANUAL** program sets an intensity level that does not change automatically. While the workout is in progress, increase or lower the intensity level as desired using the ARROW keys.

RANDOM

The **RANDOM** program creates a terrain of hills and valleys that varies with each workout. More than one million different patterns are possible. Because workout levels are greater in this workout than in the **HILL** workout, it is recommended that the **RANDOM** workout be set one or two levels lower than the workout level which would normally be selected in the **HILL** workout.

FAT BURN

The **FAT BURN** workout is designed to maintain a user’s heart rate at 65 percent of the theoretical maximum[†] for optimal results. Throughout the workout, the user wears a chest strap. If the user is not wearing a chest strap, the WORKOUT PROFILE window displays a heart shape, and the MESSAGE CENTER displays a prompt to obtain the heart rate. The console continuously monitors and displays the heart rate, adjusting the intensity level to reach and maintain the target*. This system eliminates over- and under-training and maximizes the aerobic benefits of exercise by using the body’s fat stores for fuel.

CARDIO

The **CARDIO** workout is virtually identical to **FAT BURN**, except the target heart rate is calculated at 80 percent of the theoretical maximum. As with **FAT BURN**, the user wears a chest strap throughout the **CARDIO** workout. The higher target promotes cardiovascular improvement by placing a heavier workload on the heart muscle.

[†] Defined by the American College of Sports Medicine’s “Guidelines for Exercise Testing and Prescription” as equal to 220 minus an individual’s age.

* Target Heart Rate (THR) is a percentage of the theoretical maximum. For example, a 40-year-old user’s THR for the **FAT BURN** workout is 117. This workout targets 65 percent of the maximum, so the equation would be $(220-40) \times 0.65 = 117$.

HILL

The Life Fitness-patented **HILL** workout offers a variety of configurations for interval training. Intervals are periods of intense aerobic exercise separated by regular periods of lower-intensity exercise. The **WORKOUT PROFILE** window represents these high and low intervals as columns of light, which together have the appearance of hills and valleys. The computerized interval training workout has been scientifically demonstrated to promote greater cardio-respiratory improvement than steady-pace training.

Each **HILL** workout goes through four phases, each marked by different intensity levels. The **WORKOUT PROFILE** window displays the progress of these phases, as seen in the chart following these descriptions below. As noted in the descriptions, the heart rate should be measured at two stages in the workout to gauge its effectiveness. To do so, wear the chest strap. Note that the **MES-SAGE CENTER** does not display a request for a heart rate measurement during a **HILL** workout.

- 1 **Warm-up** is a phase of low, gradually rising resistance, which brings the heart rate into the lower end of the target zone and increases respiration and blood flow to working muscles.
- 2 **Plateau** increases the intensity slightly, and keeps it steady, to bring the heart rate to the low end of the target zone. Check the heart rate at the end of this phase.
- 3 **Interval Training** is a series of increasingly steeper hills, alternating with valleys (or periods of recovery). The heart rate should rise to the high end of the target* zone. Check the heart rate at the end of this phase.
- 4 **Cool-down** is a low-intensity phase that allows the body to begin removing lactic acid and other exercise by-products, which build up in muscles and contribute to soreness.

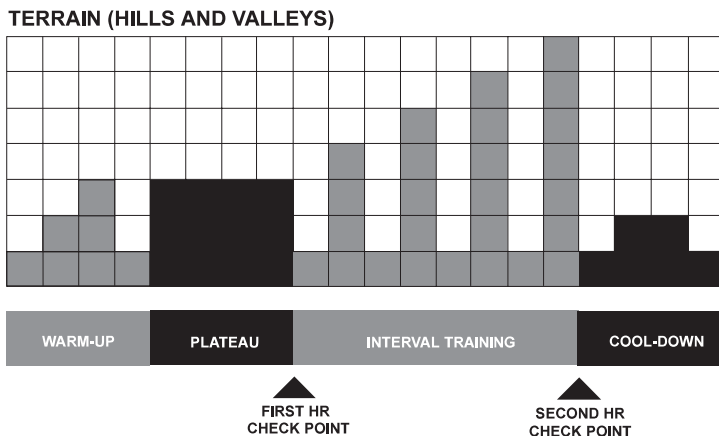

Each column, as seen in the **WORKOUT PROFILE** window and the chart above, represents one interval. The overall duration of the workout determines the length of each interval. Each workout is made up of 20 intervals, so the duration of each interval is equal to the duration of the entire workout divided by 20.

10 to 19 minutes: The interval durations initially are set at 30 seconds for a 10-minute workout. For every minute added by the user “on-the-fly,” each interval increases by three seconds. A 15-minute workout consists of 20 intervals at 45 seconds each.

20 to 99 minutes: All intervals last 60 seconds. If the user adds minutes to the pre-set duration while the workout is in progress, the program adds hills and valleys that are identical to the first eight intervals of the Interval Training phase. This pattern repeats until the workout is completed.

SIX PRE-SET WORKOUTS (93X ONLY)

AROUND THE WORLD, CASCADES, FOOTHILLS, INTERVAL, KILIMANJARO, and **SPEED TRAINING** are variations of the **HILL** workout. These workouts cannot be changed "on-the-fly."

AROUND THE WORLD is an interval-training workout in which the hills resemble scenes of various geographical areas.

CASCADES is a two-peak workout in which intensity levels gradually increase and decrease.

FOOTHILLS is a rolling hill workout with low intensity levels.

INTERVAL is a Hill workout in which intensity levels rise and fall. The higher levels gradually incline toward a peak and then gradually decline.

KILIMANJARO is a Hill workout in which the intensity levels gradually incline toward one ultimate peak and then gradually decline.

SPEED TRAINING is a Hill workout in which the intensity level alternates between high and low levels very quickly to simulate a typical speed training workout

HEART RATE HILL™ (93X ONLY)

This program combines the standard **HILL** workout profile with the concept of Heart Rate Zone Training. The default target heart rate* is calculated as 80 percent of the theoretical maximum† (HRmax), but the user can adjust the target rate during the workout setup. All hills and valleys are percentages of HRmax. The workout consists of three hills that target three heart rate goals: The first hill brings the heart rate to 70 percent of HRmax. The second hill increases the rate to 75 percent of HRmax. The third hill matches the Target Heart Rate bringing the heart rate to 80 percent of HRmax. The valley always is defined as 65 percent of HRmax.

After a standard three-minute warm-up, the workout progresses toward the first hill and heart rate goal. Once the user reaches 70 percent of HRmax, the hill continues for one minute. When the minute expires, the level decreases into a valley. Once the user's heart rate falls to 65 percent of HRmax, the valley continues for one minute. Then the next hill begins with its corresponding heart rate goal. After the user completes the third hill/valley pair, the program returns to the first hill and repeats the cycle as long as the duration allows. At the end of the duration, the workout goes into a cooldown phase. If the heart rate goes above the theoretical maximum for more than 45 seconds, the cross-trainer automatically goes into pause mode. The program does not proceed to a new heart rate goal until the user reaches the current goal. Throughout the workout, the user must wear a Polar heart rate chest strap to enable the program to monitor the heart rate.

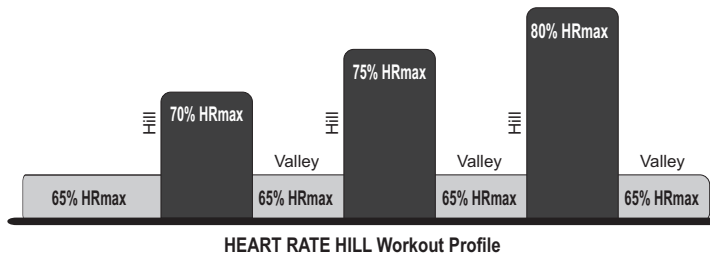

HEART RATE HILL Workout Profile

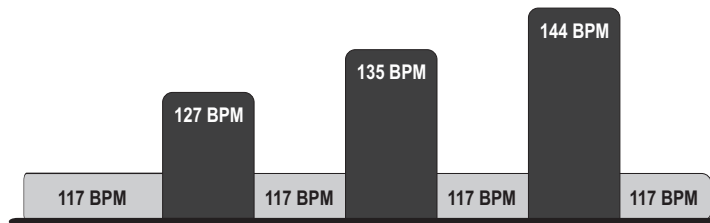

User Example: 80 percent of theoretical maximum (HRmax) (40 year old / 144 recommended BPM)

† Defined by the American College of Sports Medicine's "Guidelines for Exercise Testing and Prescription" as equal to 220 minus an individual's age.

* Target Heart Rate (THR) is a percentage of the theoretical maximum (HRmax). A 40-year-old user's recommended THR for the HEART RATE HILL workout is 144, or 80 percent of the maximum; so the equation would be $(220-40) \cdot 80 = 144$.

HEART RATE INTERVAL™ (93X ONLY)

This program also combines the standard **HILL** workout profile with the concept of Heart Rate Zone Training. The default target heart rate* is calculated as 80 percent of the theoretical maximum† (HRmax), but the user can adjust the target rate during the workout setup. The workout alternates between a hill, which brings the heart rate up to the target rate of 80 percent of HRmax, and a valley, which brings the heart rate down to 65 percent of HRmax. After a standard three-minute warm-up, the workout progresses toward the first hill and heart rate goal. Once the goal is reached, the hill continues for three minutes. Then the level decreases into a valley. Once the 65 percent of HRmax goal is reached, the valley continues for three minutes, after which the next hill begins. The user's fitness level determines the number of hills and valleys encountered within the duration. At the end of the duration, the workout goes into a cool-down phase. If the heart rate goes above the theoretical maximum† for more than 45 seconds, the cross-trainer automatically goes into pause mode. The program does not proceed to a new heart rate goal until the user reaches the current goal. Throughout the workout, the user must wear a Polar heart rate chest strap to enable the program to monitor the heart rate.

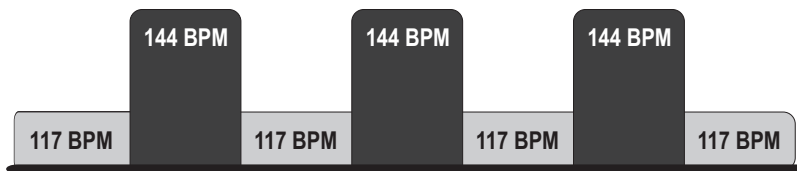
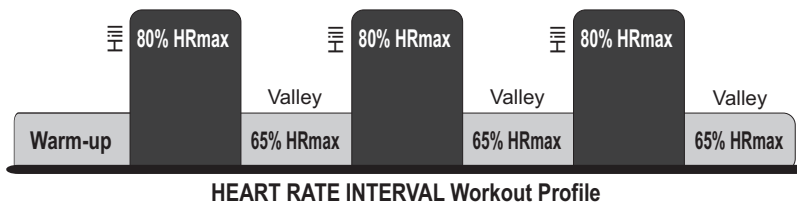

User Example: 80 percent of theoretical maximum (HRmax) (40 year old / 144 recommended BPM)

† Defined by the American College of Sports Medicine's "Guidelines for Exercise Testing and Prescription" as equal to 220 minus an individual's age.

* Target Heart Rate (THR) is a percentage of the theoretical maximum (HRmax). A 40-year-old user's recommended THR for the HEART RATE INTERVAL workout is 144, or 80 percent of the maximum; so the equation would be $(220-40) \cdot 80 = 144$.

EXTREME HEART RATE™ WORKOUT (93X ONLY)

This intense, varied workout is designed to help more experienced users to break through fitness improvement plateaus. The workout alternates between two target heart rates* as quickly as possible. The effect is similar to that of running sprints. The user must wear a Polar chest strap throughout the workout.

When setting up the workout, the user enters a target heart rate. After a standard three-minute warm-up, the intensity increases, until the user reaches the target heart rate goal of 85 percent of the theoretical maximum† (HRmax). That target rate is maintained for a stabilizing period. Then the intensity decreases. When the heart rate falls to the 65 percent of HRmax goal, it is maintained there for a stabilizing period. The program repeats the alternating of intensity levels, continuing this pattern throughout the duration. The program does not proceed to a new heart rate goal until the user reaches the current goal.

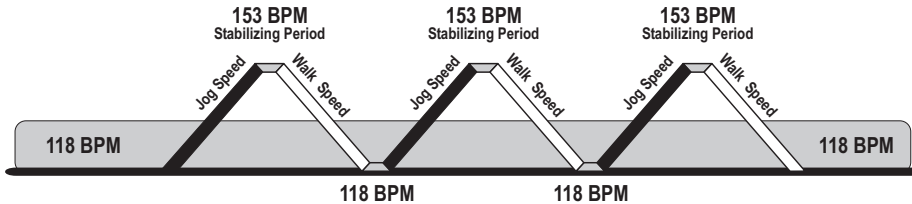
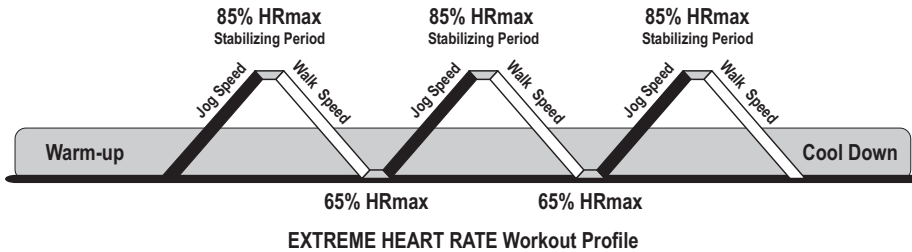

User Example 85 percent of theoretical maximum (HRmax) (40 year old / 153 recommended BPM)

† Defined by the American College of Sports Medicine's "Guidelines for Exercise Testing and Prescription" as equal to 220 minus an individual's age.

* Target Heart Rate (THR) is a percentage of the theoretical maximum (HRmax). For example, a 40-year-old user's recommended THR for the EXTREME HEART RATE™ WORKOUT is 153. The workout program targets a standard 85 percent of the maximum, so the equation would be $(220-40) \cdot 85 = 153$.

CROSS-TRAIN AEROBICS

During this workout, the MESSAGE CENTER displays prompts to emphasize different muscle groups. To emphasize upper-body muscles, the MESSAGE CENTER displays prompts to focus on pushing and pulling the moving arms at various times. To emphasize lower-body muscles, MESSAGE CENTER displays prompts to rest the hands on the stationary handlebar, thus forcing the legs to do all the work. The program also alternates between forward and reverse motion as well as different speeds.

Ten seconds after prompting the user to change pedaling direction, the workout applies “braking resistance,” that is, a high resistance level that essentially forces the user to stop pedaling. Once the user stops pedaling, the workout resumes the normal resistance level. The actual level of braking resistance depends on the user’s speed. If the user is pedaling at a rate equal to, or faster than, 6.2 mph (10.0 km/h), the workout applies the maximum level of braking resistance. If the user is pedaling at a speed below 6.2 mph (10.0 km/h), the workout applies 92 percent of the maximum.

CROSS-TRAIN AEROBICS is a constant-resistance workout. However, for a similar experience with a variable-resistance-level workout, the user can start any workout (except for Fat Burn, Cardio, Heart Rate Hill, Heart Rate Interval, or Extreme Heart Rate) and then press the AEROBICS MODE key (93x only).

CROSS-TRAIN REVERSE

During this workout, the MESSAGE CENTER displays alternating prompts to use pedal forward (for five minutes) and then backward (for two minutes.) This feature varies the emphasis on different leg muscles.

Ten seconds after prompting the user to change pedaling direction, the workout applies “braking resistance,” that is, a high resistance level that essentially forces the user to stop pedaling. Once the user stops pedaling, the workout resumes the normal resistance level. The actual level of braking resistance depends on the user’s speed. If the user is pedaling at a rate equal to, or faster than, 6.2 mph (10.0 km/h), the workout applies the maximum level of braking resistance. If the user is pedaling at a speed below 6.2 mph (10.0 km/h), the workout applies 92 percent of the maximum.

CROSS-TRAIN REVERSE is a constant-resistance workout. However, for a similar experience with a variable-resistance-level workout, the user can start any workout (except for Fat Burn, Cardio, Heart Rate Hill, Heart Rate Interval, or Extreme Heart Rate) and then press the REVERSE MODE key (93x only).

5 OPTIONAL SETTINGS

5.1 ENTERING AND USING THE OPTIONAL SETTINGS FEATURE

Fitness club managers and other authorized personnel can use the Optional Settings feature to change default settings or to enable or disable certain workouts or displays on the Life Fitness Fit Stride Total Body Trainer console.

To enter the Optional Settings, while the unit is on, hold down the UP ARROW key and press CLEAR twice. The MESSAGE CENTER displays OPTIONAL SETTINGS and then the first configuration option. Scroll forward through the options using the ENTER key or backward using the CLEAR key. For each feature or setting option, the MESSAGE CENTER displays the default setting. To change the default, press the UP or DOWN ARROW key for the desired value. Press ENTER to select the new value or setting.

To exit Optional Settings, press the CLEAR key repeatedly until the MESSAGE CENTER displays "SELECT WORKOUT USING ARROW KEYS OR PRESS QUICK START".

OPTIONAL SETTINGS		
Setting	Default Value	Description
MAX WORKOUT DURATION	60 minutes	This is the maximum possible duration for a workout. The value can range from 10 to 99.
ENGLISH/METRIC UNITS	ENGLISH	This option determines the units used for entering weight and measuring distance.
WATTS DISPLAY ENABLE/DISABLE	DISABLED	If this option is enabled, the MESSAGE CENTER displays the of Watts equivalent pedaling rate.
METS DISPLAY ENABLE/DISABLE	DISABLED	If this option is enabled, the MESSAGE CENTER displays the METs equivalent of the pedaling rate.
CAL/HR DISPLAY ENABLE/DISABLE	DISABLED	If this option is enabled, the MESSAGE CENTER displays the number of calories burned per hour during the workout.

6 SERVICE AND TECHNICAL DATA

6.1 PREVENTIVE MAINTENANCE TIPS

The Life Fitness Fit Stride Total Body Trainer is backed by the engineering excellence of Life Fitness and is one of the most rugged and trouble-free pieces of exercise equipment on the market today. Commercial Life Fitness products have proven to be durable in health clubs, colleges, and military facilities the world over. This same technology, engineering expertise, and reliability have gone into the Life Fitness Fit Stride Total Body Trainer.

NOTE: *The safety of the equipment can be maintained only if the equipment is examined regularly for damage or wear. Keep the equipment out of use until defective parts are repaired or replaced. Pay special attention to parts that are subject to wear as outlined in the Preventive Maintenance Schedule.*

REMARQUE : *pour conserver un matériel sûr, il convient de l'inspecter régulièrement afin de détecter tout signe d'usure ou d'endommagement. N'utilisez pas l'appareil tant que les pièces défectueuses n'ont pas été réparées ou remplacées. Portez une attention toute particulière aux pièces qui s'usent, comme indiqué ci-dessous.*

The following preventive maintenance tips will keep your Life Fitness Fit Stride Total Body Trainer operating at peak performance:

- Locate the Life Fitness Fit Stride Total Body Trainer in a cool, dry place.
- Clean the top surface of the pedals regularly.
- Keep the display console free of fingerprints and salt build-up caused by sweat.
- Use a 100% cotton cloth, lightly moistened with water and mild liquid detergent, to clean the cross-trainer. Other fabrics, including paper towels, may scratch the surface. Do not use ammonia, chlorine, or acid-based cleaners.
- Long fingernails may damage or scratch the surface of the console; use the pad of the finger to press the selection buttons on the console.
- Clean the housing and moving arms thoroughly on a regular basis.



NOTE: When cleaning the exterior of the unit, a non-abrasive cleaner and soft cotton cloth are strongly recommended. At no time should cleaner be applied directly to any part of the equipment; apply the non-abrasive cleaner on a soft cloth and then wipe the unit.

6.2 PREVENTIVE MAINTENANCE SCHEDULE

Follow the schedule below to ensure proper operation of the product.

ITEM	WEEKLY	MONTHLY	BI-ANNUALLY	ANNUALLY
Display Console	Clean	Inspect		
Console Mounting Bolts			Inspect	
Accessory Tray	Clean	Inspect		
Frame	Clean			Inspect
Plastic Covers	Clean	Inspect		

6.3 TROUBLESHOOTING THE POLAR® HEART RATE CHEST STRAP

Malfunction	Probable Cause	Corrective Action
Heart rate reading is erratic or absent entirely	Belt transmitter electrodes are not wet enough to pick up accurate heart rate readings.	Wet the belt transmitter electrodes (see section 3.2).
	Belt transmitter electrodes are not laying flat against the skin.	Ensure the belt transmitter electrodes are laying flat against the skin (see section 3.2).
	Belt transmitter needs cleaning.	Wash the belt transmitter with mild soap and water.
	Belt transmitter is not within 3 feet (one meter) of the heart rate receiver.	Make sure the chest strap transmitter is within three feet (one meter) of the heart rate receiver.
	Chest strap battery is depleted.	Contact Life Fitness Customer Support Services* for instructions on how to have the chest strap replaced.
Abnormally elevated heart rate readings	Electromagnetic interference from television sets and/or antennas.	Move the cross-trainer a few inches away from the probable cause, or move the probable cause a few inches away from the cross-trainer, until the heart rate readings are accurate.
	Electromagnetic interference from cell phones.	
	Electromagnetic interference from computers.	
	Electromagnetic interference from cars.	
	Electromagnetic interference from high voltage power lines.	
	Electromagnetic interference from motor driven exercise equipment.	
	Electromagnetic interference from another heart rate transmitter within three feet (one meter).	

6.4 HOW TO OBTAIN PRODUCT SERVICE

1. Verify the symptom and review the operating instructions. The problem may be unfamiliarity with the product and its features and workouts.
2. Locate the serial number plate, which is at the back end of the unit. Document the serial number, which consists of three letters followed by six numerals.
3. Contact Life Fitness Customer Support Services via the Web at: www.lifefitness.com, or call the nearest Life Fitness Customer Support Services group:

For Product Service within
the United States and Canada:

Telephone: (+1) 847.451.0036
FAX: (+1) 847.288.3702
Toll-free telephone: 800.351.3737

For Product Service Internationally:

Life Fitness Europe GmbH (Germany)
Telephone: (+49) 089.317.751.66
FAX: (+49) 089.317.751.38

Life Fitness (UK) LTD
Telephone: (+44) 1353.665.507
FAX: (+44) 1353.666.719

*Life Fitness Atlantic BV (Europe, Middle
East & Africa, except local LF offices)*
Life Fitness Benelux
Telephone: +31 180.646.666
FAX: +31 180.646.699

Life Fitness Italia S.R.L.
Telephone: 800.438.836
FAX: (+39) 0457.238.197

Life Fitness Austria Vertriebs GmbH
Telephone: (+43) 1615.7198
FAX: (+43) 1615.7198.20

*Life Fitness Asia Pacific Ltd (Asia &
Australia, except local LF offices)*
Telephone: (+852) 2891.6677
FAX: (+852) 2575.6001

*Life Fitness Latin America
and Caribbean*
Telephone: (+1) 847.288.3964
FAX: (+1) 847 288.3886

Life Fitness Brazil
Telephone: (+55) 11.4193.8282
FAX: (+55) 11.4193.8283

Life Fitness Japan
Telephone: (+81) 3.3359.4309
FAX: (+81) 3.3359.4307

Life Fitness Iberia (Spain)
Telephone: (+34) 93.672.4660
FAX: (+34) 93.672.4670

7 SPECIFICATIONS

7.1 LIFE FITNESS 93X FIT STRIDE™ TOTAL BODY TRAINER

Designed use:	Heavy/Commercial
Maximum user weight:	350 pounds / 160 kilograms
Power requirements:	None.
Console:	
Type:	MESSAGE CENTER with ARROW keys
Displays:	Elapsed time, speed, level, calories, heart rate, distance, calories burned per hour (when enabled), watts (when enabled), and METS (when enabled)
Summaries:	Total elapsed time of workout, total calories burned, total distance
Character size:	0.54 inches / 1.4 centimeters
Workouts:	Manual, Random, Hill, Cross-train Aerobics, Cross-train Reverse, Fat Burn, Cardio, Heart Rate Hill, Heart Rate Interval, Extreme Heart Rate, Around the World, Cascades, Kilimanjaro, Speed Training, Interval, Foothills, Quick Start
Modes:	Aerobics and Reverse modes during all workouts except for Fat Burn, Cardio, Heart Rate Hill, Heart Rate Interval, and Extreme Heart Rate
Heart rate monitor:	Polar® telemetry heart rate monitoring system: standard on all models Polar® heart rate chest strap: optional
Resistance Levels:	25
Pedal speed range:	1.5 mph - 14.3 mph (2.4 km/h - 23.0 km/h)
Drive type:	Belt/alternator
Accessory Tray:	Standard
Integrated Reading Rack:	Standard
Color:	Silver with gray accents

PHYSICAL DIMENSIONS:

Length:	83.5 inches / 212 centimeters
Width:	42 inches / 107 centimeters
Height:	63 inches / 160 centimeters
Weight:	286 pounds / 130 kilograms

SHIPPING DIMENSIONS:

Length:	85.75 inches / 217.8 centimeters
Width:	29.25 inches / 74.3 centimeters
Height:	50.75 inches / 128.9 centimeters
Weight:	390 pounds / 176.9 kilograms

7.2 LIFE FITNESS 90X FIT STRIDE™ TOTAL BODY TRAINER

Designed use: Light/Commercial
Maximum user weight: 350 pounds / 160 kilograms
Power requirements: None.

CONSOLE:

Type: Message Center with arrow keys
Displays: Elapsed time, speed, level, calories, heart rate, and distance
Summaries: Total elapsed time of workout, total calories burned, total distance
Character size: 0.54 inches / 1.4 centimeters

WORKOUTS:

Basic: Manual, Random, Hill, Cross-train Aerobics, Cross-train Reverse, Fat Burn, Cardio, Quick Start
Heart rate monitor: Polar® telemetry heart rate monitoring system: optional in U.S.A.; standard internationally.
Polar® heart rate chest strap: optional
Resistance Levels: 25
Pedal speed range: 1.5 mph - 14.3 mph (2.4 km/h - 23.0 km/h)
Drive type: Belt/alternator
Accessory Tray and reading rack: Optional
Color: Silver with gray accents

PHYSICAL DIMENSIONS:

Length: 83.5 inches / 212 centimeters
Width: 42 inches / 107 centimeters
Height: 63 inches / 160 centimeters
Weight: 286 pounds / 130 kilograms

SHIPPING DIMENSIONS:

Length: 85.75 inches / 217.8 centimeters
Width: 29.25 inches / 74.3 centimeters
Height: 50.75 inches / 128.9 centimeters
Weight: 390 pounds / 176.9 kilograms



M051-00K62-A026