

MATRIX

PREMIUM SERIES
STEPPER

TABLE OF CONTENTS

		PAGES
CHAPTER 1: IMPORTANT SAFETY INSTRUCTIONS		
1.1	Before Getting Started	03
1.2	Proper Usage	03
1.3	Read and Save These Instructions	03
1.4	Electrical Requirements	04
1.5	Battery Charge (5x, 7x)	04
1.6	Grounding Instructions	04
CHAPTER 2: PREVENTATIVE MAINTENANCE		
2.1	Cleaning Tips	04
2.2	Check for Damage Parts	04
2.3	Care and Maintenance Instructions	05
2.4	Preventative Maintenance Check List	05
CHAPTER 3: USING MANAGER PREFERENCE		
3.1	Using Manager Preference Mode	06
CHAPTER 4: SERIAL NUMBER LOCATION		
4.1	Stepper Serial Number Location	06
4.2	Universal Console Serial Number Location	06
CHAPTER 5: USING THE STEPPER		
5.1	Console Description	07
5.2	Manual Workout Operation	10
5.3	Operating Level Based Programs	10
5.4	Heart Rate Control Workout Operation	10
5.5	Fit Test	11
CHAPTER 6: STEPPER SPECIFICATIONS, PARTS AND ASSEMBLY GUIDE		
6.1	Model Specifications	12
6.2	Fasteners and Assembly Tools	13
6.3	Assembly Steps	14

CHAPTER 1: IMPORTANT SAFETY INSTRUCTIONS

1.1 BEFORE GETTING STARTED

It is the sole responsibility of the purchaser of Matrix Fitness Systems products to instruct all individuals, whether they are the end user or supervising personnel, on proper usage of the equipment.

It is recommended that all users of Matrix Fitness Systems exercise equipment be informed of the following information prior to its use.

1.2 PROPER USAGE

Do not use the equipment in any way other than designed or intended by the manufacturer. It is imperative that all Matrix Fitness Systems equipment is used properly to avoid injury.

- Keep hands and feet clear of moving parts at all times to avoid injury.
- Unsupervised children must be kept away from this equipment.
- Do not wear loose clothing while on equipment.

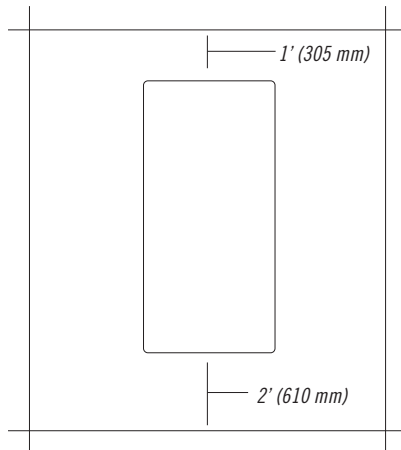

Stepper

Please leave a 24" (610 mm) behind the stepper. This zone is to allow easy access to the stepper and gives the user an easy exit path from the machine.

1.3 READ AND SAVE THESE INSTRUCTIONS

- This stepper is intended for commercial use
- To insure your safety and protect the equipment, read all instructions before operating the MATRIX Stepper.
- Unsupervised Children must be kept away from this equipment

When using an electrical product, basic precautions should always be followed, including the following:

- Always unplug this equipment from the electrical outlet immediately after using and before cleaning.

WARNING: To reduce the risk of burns, fire, electrical shock or injury to persons that may be associated with using this product:

- An appliance should never be left unattended when plugged in. Unplug the entertainment equipment from outlet when not in use and before putting on or taking off parts.
- This product must be used for its intended purpose described in this Owner's Guide. Do not use other attachments that are not recommended by the manufacturer. Attachments may cause injury.
- To prevent electrical shock, never drop or insert any object into any opening.
- Do not remove side covers. Service should only be done by an authorized service technician.
- Never operate the Stepper with the air opening blocked. Keep the air opening clean, free, of lint, hair and the like.
- Never operate the product if it has a damaged cord or plug, if it is not working properly, if it has been damaged, or immersed in water. Return the unit to a service center for examination and repair.
- Do not carry this unit by entertainment equipment power cord or use cord as handle.
- Keep any of the entertainment equipment power cords away from heated surfaces
- Keep hands and loose clothing away from moving parts.
- Close supervision is necessary when the Stepper is used by or near children or disabled persons.
- Do not use outdoors.
- Do not operate where aerosol (spray) products are being used or where oxygen is being administered.
- Connect this Stepper to a properly grounded outlet only.
- To disconnect, turn all entertainment controls to the off position, then remove plug from outlet.

CAUTION: If you experience chest pain, nausea, dizziness or shortness of breath, **STOP** exercising immediately and consult a physician before continuing.

1.4 ELECTRICAL REQUIREMENTS

The Matrix Stepper has different electrical requirements depending on the model chosen. The chart below should assist you with your facility planning:

5x: These products are designed to be self powered and do not require an external power supply source to operate. However, these units can be AC powered if an optional power cord is purchased. This will power the console at all times and requires no minimum RPM for operation. These units can be daisy-chained together, up to 4 units per dedicated 15 amp circuit, using a Matrix daisy-chain cord adapter (sold separately).

7x: These products can operate without power; however, the machine must boot the software with each new user. This can mean a delay of up to 35 seconds while the machine's operating system prepares for a workout. It's similar to turning your cell phone on for the 1st time of the day. These units can also be AC powered. This will power the console at all times and requires no minimum RPM for operation. A powered product lowers the starting resistance and is easier to use for beginners. These units can be daisy-chained together, up to 4 units per dedicated 15 amp circuit, using a Matrix daisy-chain cord adapter (sold separately).

7xe: These products must be AC powered. These units can be daisy-chained together, up to 4 units per dedicated 15 amp circuit, using a Matrix daisy-chain cord adapter (sold separately).

For your safety and for the performance of your Matrix product, the ground on your circuits must be non-looped. Please refer to NEC article 210-21 and 210-23. Any alterations to the standard Matrix power cords will void all warranties.

1.5 BATTERY CHARGE (5X, 7X)

The Stepper saves its battery charge by moving into a shutdown mode whenever STEP FASTER appears on the display. If the user does not maintain a step rate above 35 steps per minute, then a 30-second shutdown process begins.

When the battery voltage is low, LOW BATTERY appears on the display if the unit is moving into the shutdown mode. The following situation is the time to recharge the battery:

- If no one has used the unit for an extended period of time, the battery may need recharging.
- The unit continues to function with a low battery, however, user and program information is lost once the user stops.

If the battery must be recharged, use the optional power adapter charging unit. The charger should be connected to the Stepper for a minimum of eight hours to ensure a thorough charge. After a completion of charge, the battery light turns from red into green (see illustration). If LOW BATTERY still appears on the display in a full of charging, the battery could be extinct. Please check with an authorized service technician for replacing the battery.

CAUTION: The battery stored inside the unit contains hazardous materials to the environment. Proper disposal of the battery is required by the local law.

1.6 GROUNDING INSTRUCTIONS

The stepper must be grounded. If it should malfunction or breakdown, grounding provides a path of least resistance for electric current to reduce the risk of electric shock. The stepper is equipped with a cord having an equipment-grounding conductor and a grounding plug. The plug must be plugged into an appropriate outlet that is properly installed and grounded in accordance with all local codes and ordinances. If the user does not follow these grounding Instructions, the user could void the Matrix limited warranty.

DANGER: Improper connection of the equipment-grounding conductor can result in the risk of electric shock. Check with a qualified electrician or serviceman if the user is in doubt as to whether the product is properly grounded. Do not modify the plug provided with the product if it will not fit the outlet; have a proper outlet installed by a qualified technician.

2.1 RECOMMENDED CLEANING TIPS

Preventative maintenance and daily cleaning will prolong the life and look of your MATRIX Stepper.

Please read and follow these tips.

- Position the equipment away from direct sunlight. The intense UV light can cause discoloration on plastics.
- Locate your equipment in an area with cool temperatures and low humidity.
- Clean with a soft 100% cotton cloth.
- Clean with soap and water or other non-ammonia based all purpose cleaners.
- Wipe foot pads, handles, heart rate grips, and handlebars clean after each use.
- Do not pour liquids directly onto your equipment. This can cause damage to the equipment and in some cases electrocution.
- Check pedal motion and stability.
- Adjust leveling feet when equipment wobbles or rocks.
- Maintain a clean area around equipment, free from dust and dirt.

2.2 CHECK FOR DAMAGED PARTS

DO NOT use any equipment that is damaged or has worn or broken parts. Use only replacement parts supplied by Matrix Fitness Systems.

MAINTAIN LABELS AND NAMEPLATES. Do not remove labels for any reason. They contain important information. If unreadable or missing, contact Matrix Fitness Systems for a replacement. 1-866-693-4863, www.matrixfitness.com

MAINTAIN ALL EQUIPMENT Preventative maintenance is the key to smooth operating equipment. Equipment needs to be inspected at regular intervals. Defective components must be replaced immediately. Improperly working equipment must be kept out of use until it is repaired. Ensure that any person(s) making adjustments or performing maintenance or repair of any kind is qualified to do so. Matrix Fitness Systems will provide service and maintenance training at our corporate facility upon request or in the field if proper arrangements are made.

CHAPTER 2: PREVENTATIVE MAINTENANCE

2.3 CARE AND MAINTENANCE INSTRUCTIONS

In order to maximize life span, and minimize down time, all MATRIX equipment requires regular cleaning, and maintenance items performed on a scheduled basis. This section contains detailed instructions on how to perform these items, the frequency of which they should be done, and a check list to sign off each time service is completed for a specific machine. Some basic tools and supplies will be necessary to perform these tasks which include (but may not be limited to):

Metric Allen wrenches
 #2 Phillips head screwdriver
 Adjustable wrench
 Torque wrench (capability to read foot lbs, and inch lbs)
 Lint free cleaning cloths
 Teflon based spray lubricant
 Mild, water soluble, detergent – such as “Simple Green”, or other Matrix approved product
 Teflon based spray lubricant such as “Super Lube”, or other Matrix approved product
 Vacuum cleaner w/extendable hose and crevasse tool attachment

Please find the worksheet sample for our equipment provided in this manual and make copies as needed, keeping them up to date as the required service/maintenance items are performed. It is critical that you also log the accumulated (total) amount of miles or running hours on the equipment each time service or maintenance is performed.

You may periodically see addendums to this document, as the Matrix Technical Support Team identifies items that require specific attention, the latest version will always be available on the Matrix website, matrixfitness.com

DAILY MAINTENANCE ITEMS

- 1) Clean entire machine use water and mild detergent such as “Simple Green”, or other Matrix approved solution (cleaning agents should be alcohol and ammonia free).

2.4 PREVENTATIVE MAINTENANCE CHECKLIST

Facility: _____

MAKE:	MODEL:	S/N
LOCATION:	TECHNICIAN:	DATE:

Inspect power cords ___ Check resistance system ___ Clean/lube guide rods
 Check E-stop cord/button ___ Lubricate pivot points ___ Inspect belt/cable assy.
 Vacuum/clean under cover ___ Check connecting joints ___ Check locking pins
 Check motor drive belt ___ Remove covers, check belts ___ Check pulleys
 Check running belt ___ Check pedal & crank ___ Inspect upholstery
 Flip/replace deck ___ Check/lube seat adjustment ___ Check/tighten hardware
 De-wax rollers ___ Verify electronics operation ___ Lubricate Acme screw

Notes/comments _____

MAKE:	MODEL:	S/N
LOCATION:	TECHNICIAN:	DATE:

Inspect power cords ___ Check resistance system ___ Clean/lube guide rods
 Check E-stop cord/button ___ Lubricate pivot points ___ Inspect belt/cable assy.
 Vacuum/clean under cover ___ Check connecting joints ___ Check locking pins
 Check motor drive belt ___ Remove covers, check belts ___ Check pulleys
 Check running belt ___ Check pedal & crank ___ Inspect upholstery
 Flip/replace deck ___ Check/lube seat adjustment ___ Check/tighten hardware
 De-wax rollers ___ Verify electronics operation ___ Lubricate Acme screw

Notes/comments _____

3.1 USING MANAGER PREFERENCE MODE

This section allows a user to manipulate default settings for the machines. It may be accessed by pressing the **LEVEL UP/LEVEL DOWN** simultaneously for 5 seconds. To change a setting, press "**ENTER**" on the keypad and use the Level buttons and numeric keypad to change the values. Pressing "**ENTER**" again will save the change. Pressing "**BACK**" will bring you to the previous menu. To exit manager's mode, hold "**STOP**" down for 5 seconds. Below is a list of the settings.

- Maximum Time
- Default Time
- Default Level
- Default Age
- Default Weight
- Accumulated Distance
- Accumulated Time
- Software Version
- Timer Mode
- Speed/Distance Mode
- Out of Order
- Gender
- Language
- Sound Mode

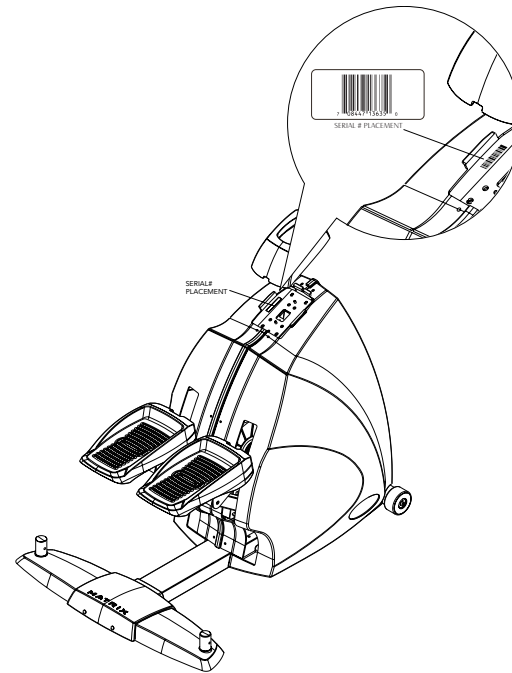
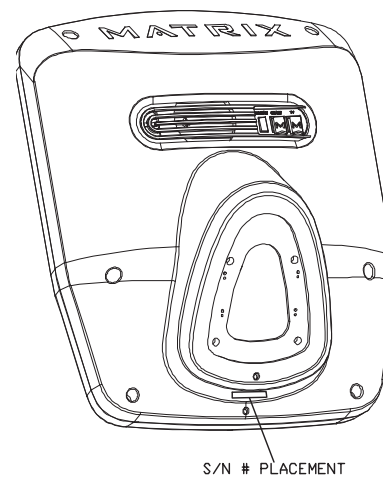
4.1 STEPPER SERIAL NUMBER LOCATION**4.2 UNIVERSAL CONSOLE SERIAL NUMBER LOCATION**

CHAPTER 5: S5x OVERLAY AND WORKOUT DESCRIPTION

5.1 S5x CONSOLE DESCRIPTION

The MATRIX stepper is inspected before it is packaged. It is shipped in two pieces: the base and the console. Carefully unpack the unit and dispose of the box material.



WORKOUT KEYS: Simple program view and selection buttons.

GO: One touch Start.

ENTER: To confirm each program setting.

UP/DOWN LEVEL: Easy information and level selection.

UP/DOWN TIME: Easy information and time adjustment.

STOP: Ends workout and shows workout summary data.

NUMBER KEYPAD: Workout data input for workout setup. Level adjustment during workout.

COOL DOWN: Puts stepper into Cool Down mode.

FAN: Allows for fan speed selection (fan has three operating speeds.)

TOGGLE DISPLAY: Allows user to select what information is displayed on the console.

CHAPTER 5: S7x OVERLAY AND WORKOUT DESCRIPTION

S7x CONSOLE DESCRIPTION

The MATRIX stepper is inspected before it is packaged. It is shipped in two pieces: the base and the console. Carefully unpack the unit and dispose of the box material.



MULTI-PURPOSE KEYS: Keys have different functions depending on each screen.

GO: One touch Start.

ENTER: To confirm each program setting.

UP/DOWN LEVEL: Easy information and level selection.

UP/DOWN TIME: Easy information and time adjustment.

STOP: Ends workout and shows workout summary data.

NUMBER KEYPAD: Workout data input for workout setup.

COOL DOWN: Puts stepper into Cool Down mode.

FAN: Allows for fan speed selection (fan has three operating speeds.)

S7x ENTERTAINMENT ZONE

iPOD®: Will take the user directly to the iPod screen to allow for iPod control and playlist selection.

VOLUME UP/DOWN: Adjusts the volume output through the headphone jack of the integrated console TV or iPod output.

NUMBER KEYPAD: Allows for easy TV channel selections.

CHANNEL UP/DOWN: Allows for channel selection.

DISPLAY MODE: Allows user to cycle through console display options, iPod, TV or profile display.

LAST CHANNEL: Allows the user to cycle between the current channel and the previous channel viewed.

CHAPTER 5: S7xe OVERLAY AND WORKOUT DESCRIPTION

S7xe CONSOLE DESCRIPTION

The MATRIX stepper is inspected before it is packaged. It is shipped in two pieces: the base and the console. Carefully unpack the unit and dispose of the box material.



The S7xe has a full integrated touch screen display. All information required for workouts is explained on screen. Exploration of the interface is highly encouraged. The information explaining how to program for various workouts will give an explanation about the contents of each screen on the S7xe.

S7xe ENTERTAINMENT ZONE

iPOD®: Will take the user directly to the iPod screen to allow for iPod control and playlist selection.

VOLUME UP/DOWN: Adjusts the volume output through the headphone jack.

NUMBER KEYPAD: Allows for easy TV channel selections.

CHANNEL UP/DOWN: Allows for channel selection.

DISPLAY MODE: Allows user to cycle through console display options, iPod, TV or profile display.

LAST CHANNEL: Allows the user to cycle between the current channel and the previous channel viewed.

QUICK START: One-touch start. Starts a manual workout.

5.2 MANUAL WORKOUT OPERATION

QUICK START OPERATION

Press the **GO** button and the stepper will enter into a manual mode of operation. All energy expenditure values will be calculated using the default weight measurement.

MANUAL WORKOUT OPERATION

Manual is a workout that allows you to manually adjust the level values at anytime. The manual workout also contains a setup screen which allows you to input your weight to help calculate a more accurate caloric burn rate.

To enter into this workout on a S5x, use the following guidelines:

1. Choose **MANUAL** by selecting the manual workout button and press **ENTER**.
2. Enter the desired workout length using the **ARROW KEYS** or the **NUMBER KEYPAD** and press **ENTER**.
3. Enter user weight (user weight is used to calculate the caloric expenditure value-providing an accurate weight helps to ensure an accurate caloric expenditure rating for each user) using the **ARROW KEYS** or the **NUMBER KEYPAD** and press **ENTER**.
4. Enter the desired initial level using the **ARROW KEYS** or the **NUMBER KEYPAD** and press **ENTER**.

To enter into this workout on a S7x or S7xe, follow the onscreen prompts.

5.3 OPERATING LEVEL BASED PROGRAMS

Your Matrix stepper offers a variety of level-based workouts to challenge users of all fitness levels. The following information will briefly explain the workout and how to program the stepper for each workout selection.

ROLLING HILLS WORKOUT OPERATION

Rolling hills is a level-based workout that automatically adjusts the level value to simulate walking or running up hills.

1. Choose **ROLLING HILLS** by selecting the rolling hills workout button and press **ENTER**.
2. Enter the desired intensity using the **ARROW KEYS** or the **NUMBER KEYPAD** and press **ENTER**.
3. Enter the desired workout length using the **ARROW KEYS** or the **NUMBER KEYPAD** and press **ENTER**.
4. Enter user weight (user weight is used to calculate the caloric expenditure value, providing an accurate weight helps to ensure an accurate caloric expenditure rating for each user) using the **ARROW KEYS** or the **NUMBER KEYPAD** and press **ENTER**.

To enter into this workout on a S7x or S7xe, follow the onscreen prompts.

FAT BURN WORKOUT OPERATION

Fat burn is a level-based workout that is designed to help user's burn fat through various resistance changes.

To enter into this workout on a S5x, use the following guidelines:

1. Choose **FAT BURN** by selecting the fat burn workout button and press **ENTER**.
2. Enter the desired intensity level using the **ARROW KEYS** or the **NUMBER KEYPAD** and press **ENTER**.

3. Enter the desired workout length using the **ARROW KEYS** or the **NUMBER KEYPAD** and press **ENTER**.
4. Enter user weight (user weight is used to calculate the caloric expenditure value, providing an accurate weight helps to ensure an accurate caloric expenditure rating for each user) using the **ARROW KEYS** or the **NUMBER KEYPAD** and press **ENTER**.

To enter into this workout on a S7x or S7xe, follow the onscreen prompts.

5.4 HEART RATE CONTROL WORKOUT OPERATION

Your Matrix stepper offers a heart rate control workout mode. The heart rate control workout mode allows the user to program their desired heart rate zone and the stepper will automatically adjust the level based upon the user's heart rate. The heart rate zone is calculated using the following equation: $(220 - \text{Age}) * \% = \text{target heart rate zone}$. The user must wear a telemetric heart rate monitor or continually hold onto the contact heart rate grips for this workout.

To enter into this workout on a S5x, use the following guidelines:

1. Choose **TARGET HEART RATE** by selecting the target heart rate workout button and press **ENTER**.
2. Enter age using the **ARROW KEYS** or the **NUMBER KEYPAD** and press **ENTER**.
3. Enter the desired percent of maximum heart rate using the **ARROW KEYS** and press **ENTER**.
4. Enter the desired workout length using the **ARROW KEYS** or the **NUMBER KEYPAD** and press **ENTER**.
5. Enter user weight (user weight is used to calculate the caloric expenditure value, providing an accurate weight helps to ensure an accurate caloric expenditure rating for each user) using the **ARROW KEYS** or the **NUMBER KEYPAD** and press **ENTER**.

To enter into this workout on a S7x or S7xe, follow the onscreen prompts.

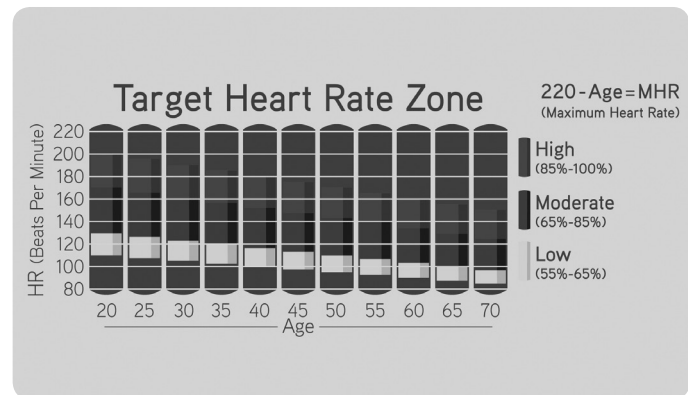

CHAPTER 5: S5x, S7x, S7xe OVERLAY AND WORKOUT DESCRIPTION

5.5 FIT TEST

FIT TEST program is to monitor the development of your cardiovascular system and measure your fitness level based on your average heart rate during specific test stages. When the 5-minute test is completed, the display provides a fitness score and fitness category.

Follow these easy steps to enter in the Fit Test Program.

- STEP 1:** Select the **FIT TEST** button.
- STEP 2:** Select **AGE** by using the **UP** or **DOWN** arrow keys. Press **SELECT** or wait 5 seconds.
- STEP 3:** Select **GENDER** by using the **UP** or **DOWN** arrow keys. Press **SELECT** or wait 5 seconds.
- STEP 4:** Select **WEIGHT** by using the **UP** or **DOWN** arrow keys. Press **START** or **SELECT** to begin workout. Display, Starting 3, Starting 2, Starting 1.
- STEP 5:** Display will read results of FIT TEST.

MEN'S OUTPUT TABLE FOR FIT TEST

Age	EXCELLENT	GOOD	ABOVE AVERAGE	AVERAGE	BELOW AVERAGE	POOR	VERY POOR
18-25	<79	79-89	90-99	100-105	106-116	117-128	>128
26-35	<81	81-89	90-99	100-107	108-117	118-128	>128
36-45	<83	83-96	97-103	104-112	113-119	120-130	>130
46-55	<87	87-97	98-105	106-116	117-122	123-132	>132
56-65	<86	86-97	98-103	104-112	113-120	121-129	>129
65 +	<88	88-96	97-103	104-113	114-120	121-130	>130

WOMEN'S OUTPUT TABLE FOR FIT TEST

Age	EXCELLENT	GOOD	ABOVE AVERAGE	AVERAGE	BELOW AVERAGE	POOR	VERY POOR
18-25	<85	85-98	99-108	109-117	118-126	127-140	>140
26-35	<88	88-99	100-111	112-119	120-126	127-138	>138
36-45	<90	90-102	103-110	111-118	119-128	129-140	>140
46-55	<94	94-104	105-115	116-120	121-129	130-135	>135
56-65	<95	95-104	105-112	113-118	119-128	129-139	>139
65 +	<90	90-102	103-115	116-122	123-128	129-134	>134













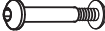

CHAPTER 6: S5x, S7x, S7xe STEPPER SPECIFICATIONS, PARTS, AND ASSEMBLY GUIDES

6.1 S5x, S7x, S7xe MODEL SPECIFICATIONS

	S7xe	S7x	S5x
Features			
Step range	12.2"	12.2"	12.2"
Contact & telemetric HR	Yes	Yes	Yes
Ultra non-slip pedals	Yes	Yes	Yes
Q-factor	3.3"	3.3"	3.3"
Handlebar design	Ergonomically designed handrails and horn	Ergonomically designed handrails and horn	Ergonomically designed handrails and horn
Thumb switch controls	Yes	Yes	Yes
Resistance System			
Technology	JID brushless generator	JID brushless generator	JID brushless generator
Power requirements	120v/60Hz AC power	Self-powered/optional AC power jack	Self-powered/optional AC power jack
Minimum watts	18	18	18
Console			
Display type	15" touch screen LCD	7" LCD	Dot-matrix LED
Display feedback	Time, distance (kilometers or miles), calories, calories per hour, speed, SPM, floors climbed, heart rate, METS, watts, dynamic profile display, static profile display	Time, distance (kilometers or miles), calories, calories per hour, speed, incline, pace, heart rate, METS, Watts, Profile	Time, speed, floors climbed, calories, watts, level, heart rate, SPM
User defined multi-language display	Yes-English, German, French, Italian, Spanish, Dutch, Portuguese, Chinese, Japanese	Yes-English, German, French, Italian, Spanish, Dutch, Portuguese, Chinese, Japanese	No
Resistance levels	25	25	25
Workouts	Manual, rolling, intervals, fat burn, random, target HR, constant watts, fit test	Manual, rolling, intervals, fat burn, random, target HR, constant watts, fit test	Manual, rolling, intervals, fat burn, random, target HR, constant watts, fit test
CSAFE, FitLinxx™ ready	Yes	Yes	Yes
On-the-fly program change	Yes	Yes	Yes
Fit Touch™ Technology	Yes	No	No
Integrated Vista Clear Digital Ready Television	Yes-15" screen size	Yes-7" screen size	No
Wireless Data transmitter	Yes	Yes	Yes
iPod compatible	Yes	Yes	No
Nike + iPod compatible	Yes	Yes	No
Personal Fan	Yes	Yes	Yes
Tech Specs			
Overall dimensions	45"L x 31"W x 70.5" H	45"L x 31"W x 70.5" H	45"L x 31"W x 70.5" H
Maximum user weight	400lbs	400lbs	400lbs
Weight	211lbs	209lbs	208lbs
Shipping weight	239lbs	237lbs	236lbs
Electrical Requirements	AC powered	Self-power, power optional	Self-power, power optional

CHAPTER 6: S5x, S7x, S7xe STEPPER SPECIFICATIONS, PARTS, AND ASSEMBLY GUIDES

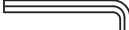
6.2 REQUIRED FASTENERS & ASSEMBLY TOOLS

REFERENCE	SKETCH	DESCRIPTION	QUANTITY	PACKAGE COLOR
Z01		SOCKET HEAD BOLT(M8x16L)	8	WHITE
Z02		LOCK WASHER	8	WHITE
Z34		SOCKET HEAD BOLT(M8x25L)	2	BLUE
Z02		LOCK WASHER	4	BLACK
Z07		BUTTON HEAD BOLT(M8x40L)	4	BLACK
Z02		LOCK WASHER	2	YELLOW
Z10		BUTTON HEAD BOLT(M8x45L)	2	YELLOW
Z03		SCREW SET	2	ORANGE
Z05		BUTTON HEAD BOLT(M8x16L)	4	ORANGE
Z06		ARC WASHER	8	ORANGE
Z04		LOCK WASHER	3	GREEN
Z05		BUTTON HEAD BOLT(M8x16L)	3	GREEN
Z09		BUTTON HEAD BOLT(M5x15L)	4	RED
Z50		PHILLIPS DRIVER(4.5x50mm)	1	PURPLE
Z52		5mm ALLEN WRENCH	2	PURPLE
Z53		6mm ALLEN WRENCH	1	PURPLE

6.3 ASSEMBLY STEPS

STEP 1

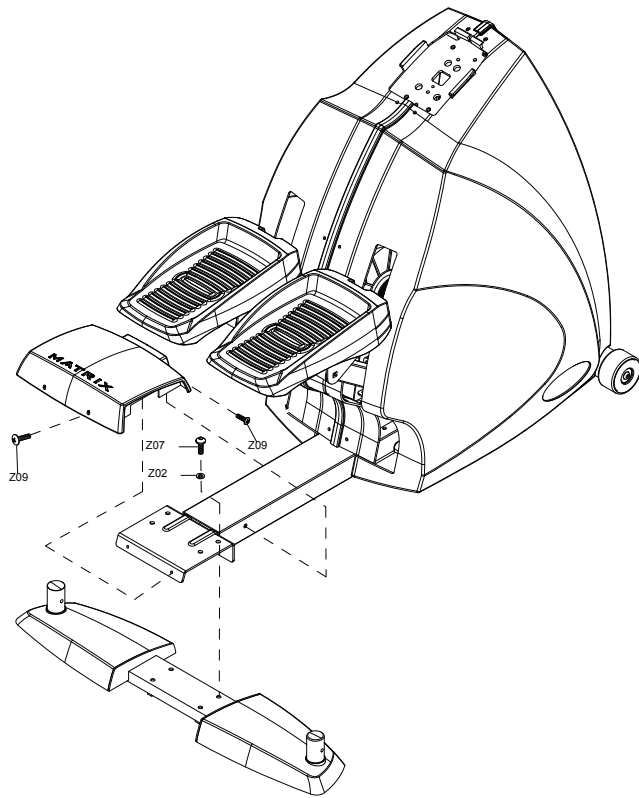

STEP 2

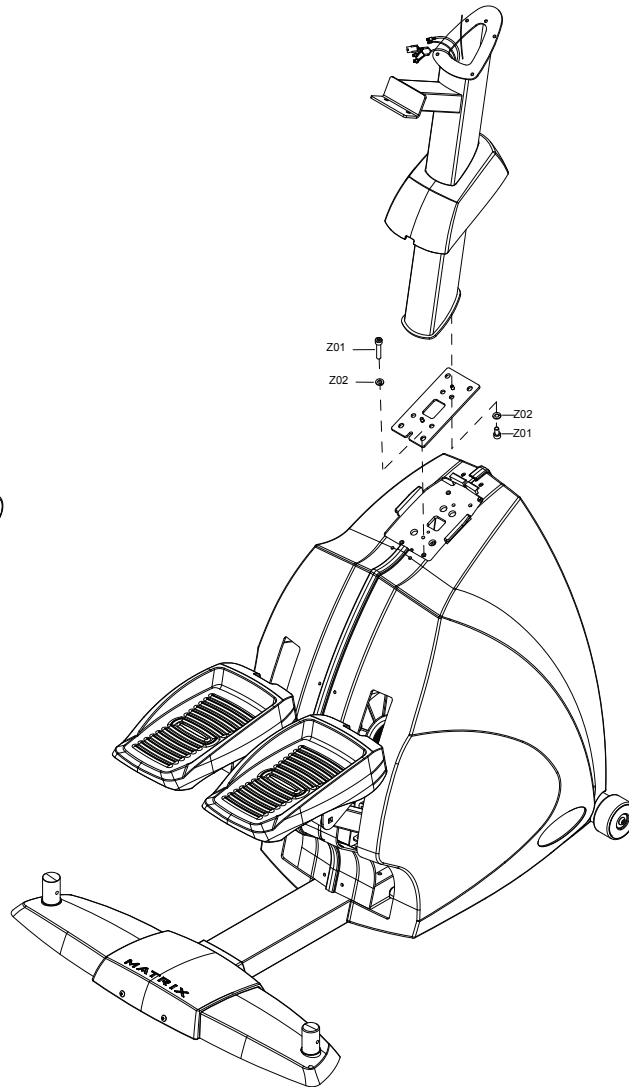

6.3 ASSEMBLY STEPS

STEP 3

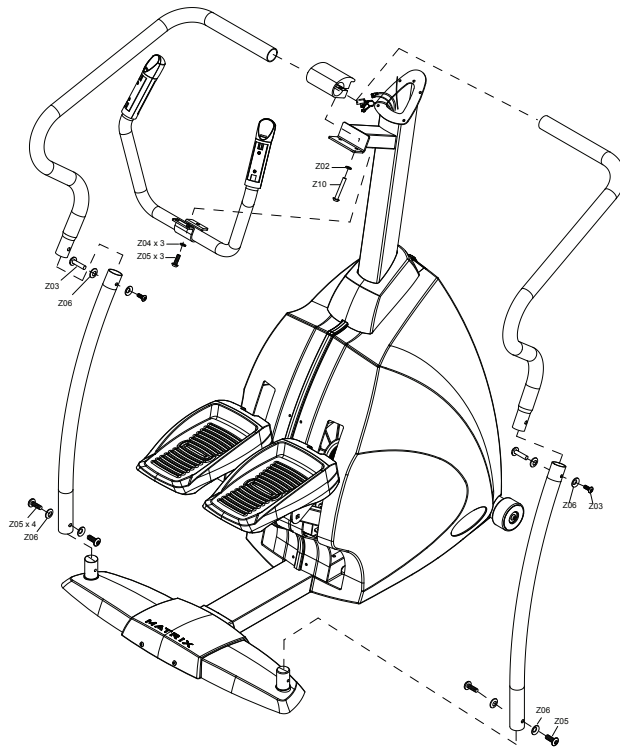

STEP 4

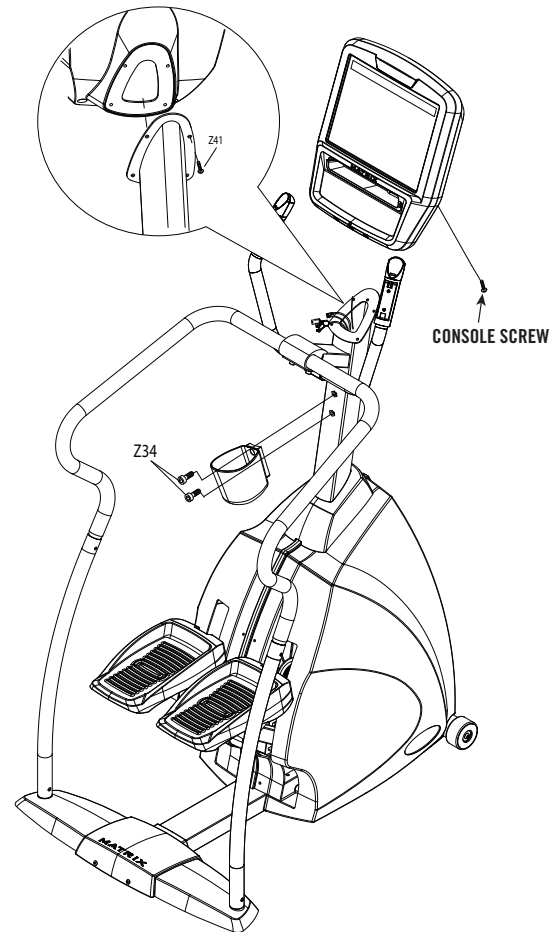

FINAL ASSEMBLY

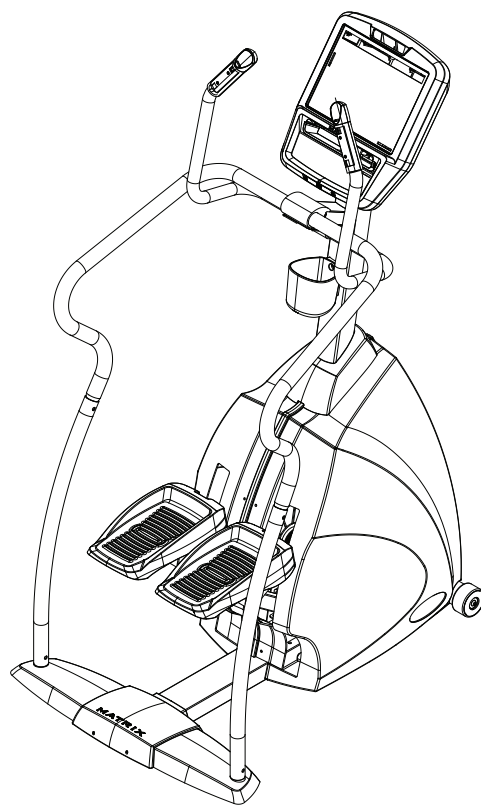



Strong. Smart. Beautiful.

MATRIX FITNESS SYSTEMS | 1610 LANDMARK DRIVE COTTAGE GROVE WI 53527 USA
Toll Free 866.693.4863 matrixfitness.com Fax 608.839.8687

PART # 0000088210

REV. 1.4