

# **NordicTrack**<sup>®</sup> **ELITE 7500**

[www.nordictrack.com](http://www.nordictrack.com)

Model No. NTL19007.4

Serial No. \_\_\_\_\_

Write the serial number in the space above for reference.

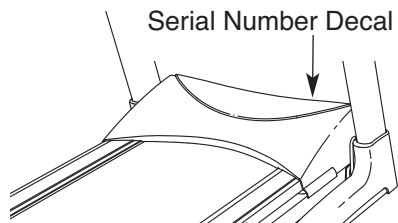

## QUESTIONS?

As a manufacturer, we are committed to providing complete customer satisfaction. If you have questions, or if parts are damaged or missing, **DO NOT CONTACT THE STORE; please contact Customer Care.**

**IMPORTANT:** You must note the product model number and serial number (see the drawing above) before contacting us:

CALL TOLL-FREE:

**1-888-825-2588**

Mon.–Fri. 6 a.m.–6 p.m. MT

Sat. 8 a.m.–4 p.m. MT

ON THE WEB:

[www.nordictrackservice.com](http://www.nordictrackservice.com)

## USER'S MANUAL

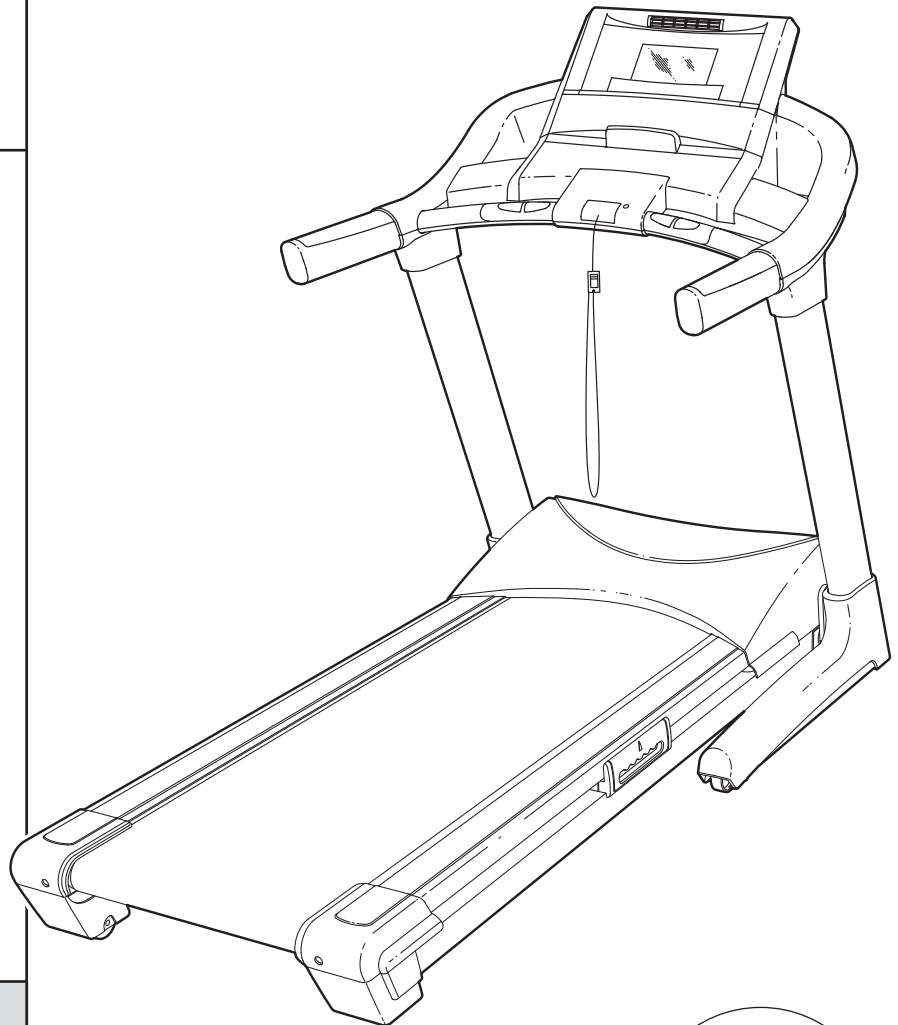

## CAUTION

Read all precautions and instructions in this manual before using this equipment. Save this manual for future reference.



# TABLE OF CONTENTS

WARNING DECAL PLACEMENT ..... 2  
 IMPORTANT PRECAUTIONS ..... 3  
 BEFORE YOU BEGIN ..... 5  
 ASSEMBLY ..... 6  
 HOW TO USE THE CHEST PULSE SENSOR ..... 11  
 OPERATION AND ADJUSTMENT ..... 12  
 HOW TO FOLD AND MOVE THE TREADMILL ..... 25  
 TROUBLESHOOTING ..... 26  
 EXERCISE GUIDELINES ..... 29  
 PART LIST ..... 30  
 ORDERING REPLACEMENT PARTS ..... Back Cover  
 LIMITED WARRANTY ..... Back Cover

Note: An EXPLODED DRAWING is attached in the center of this manual.

## WARNING DECAL PLACEMENT

**▲WARNING:**  
Protect yourself and others from risk of serious injury. Read the user's manual and :

-  -Stand only on the side rails when starting or stopping treadmill.
- Change speed in small increments.
- Hold handrails to prevent falling, and always wear the safety clip while operating treadmill.
- Stop if you feel faint, dizzy, or short of breath.
- Fully engage storage latch before treadmill is moved or stored.
- Reduce incline to its lowest level before folding treadmill into storage position.

---

-  -Never allow children on or around treadmill.
- Remove key when not in use.

---

-  -Keep clothing, fingers, and hair away from moving belt.
- Never try to adjust or fix the belt while it is moving.

---

-  -Always wear athletic shoes while operating treadmill.

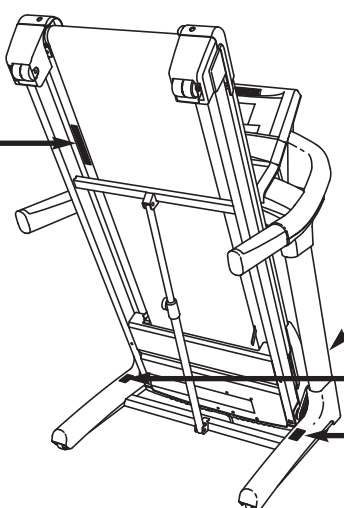

This drawing shows the locations of the warning decals. **If a decal is missing or illegible, call the telephone number on the front cover of this manual and request a free replacement decal. Apply the decal in the location shown.** Note: The decals may not be shown at actual size.

**▲ CAUTION**

KEEP HANDS AND FEET AWAY FROM THIS AREA WHILE THE TREADMILL IS IN OPERATION.

# IMPORTANT PRECAUTIONS

**⚠ WARNING:** To reduce the risk of serious injury, read all important precautions and instructions in this manual and all warnings on your treadmill before using your treadmill. ICON assumes no responsibility for personal injury or property damage sustained by or through the use of this product.

1. Before beginning this or any exercise program, consult your physician. This is especially important for persons over the age of 35 or persons with pre-existing health problems.
2. It is the responsibility of the owner to ensure that all users of this treadmill are adequately informed of all warnings and precautions.
3. Use the treadmill only as described.
4. Place the treadmill on a level surface, with at least 8 ft. (2.4 m) of clearance behind it and 2 ft. (0.6 m) on each side. Do not place the treadmill on any surface that blocks air openings. To protect the floor or carpet from damage, place a mat under the treadmill.
5. Keep the treadmill indoors, away from moisture and dust. Do not put the treadmill in a garage or covered patio, or near water.
6. Do not operate the treadmill where aerosol products are used or where oxygen is being administered.
7. Keep children under the age of 12 and pets away from the treadmill at all times.
8. The treadmill should be used only by persons weighing 350 lbs. (159 kg) or less.
9. Never allow more than one person on the treadmill at a time.
10. Wear appropriate exercise clothes when using the treadmill. Do not wear loose clothes that could become caught in the treadmill. Athletic support clothes are recommended for both men and women. *Always wear athletic shoes. Never use the treadmill with bare feet, wearing only stockings, or in sandals.*
11. When connecting the power cord (see page 12), plug the power cord into a surge suppressor (not included) and plug the surge suppressor into a grounded circuit capable of carrying 15 or more amps. No other appliance should be on the same circuit. Do not use an extension cord.
12. Use only a single-outlet surge suppressor that meets all of the specifications described on page 12. To purchase a surge suppressor, see your local NordicTrack dealer or call the telephone number on the front cover of this manual and order part number 146148, or see your local electronics store.
13. Failure to use a properly functioning surge suppressor could result in damage to the control system of the treadmill. If the control system is damaged, the walking belt may slow, accelerate, or stop unexpectedly, which may result in a fall and serious injury.
14. Keep the power cord and the surge suppressor away from heated surfaces.
15. Never move the walking belt while the power is turned off. Do not operate the treadmill if the power cord or plug is damaged, or if the treadmill is not working properly. (See TROUBLESHOOTING on page 26 if the treadmill is not working properly.)
16. Read, understand, and test the emergency stop procedure before using the treadmill (see HOW TO TURN ON THE POWER on page 14).
17. Never start the treadmill while you are standing on the walking belt. Always hold the handrails while using the treadmill.
18. The treadmill is capable of high speeds. Adjust the speed in small increments to avoid sudden jumps in speed.
19. The pulse sensors are not medical devices. Various factors, including the user's movement, may affect the accuracy of heart rate readings. The pulse sensors are intended only as an exercise aid in determining heart rate trends in general.
20. Never leave the treadmill unattended while it is running. Always remove the key, unplug the power cord, and switch the reset/off circuit breaker to the "off" position when the treadmill is not in use. (See the drawing on page 5 for the location of the reset/off circuit breaker.)

21. Do not attempt to raise, lower, or move the treadmill until it is properly assembled. (See ASSEMBLY on page 6, and HOW TO FOLD AND MOVE THE TREADMILL on page 25.) You must be able to safely lift 45 lbs. (20 kg) to raise, lower, or move the treadmill.
  22. Do not change the incline of the treadmill by placing objects under the treadmill.
  23. When folding or moving the treadmill, make sure that the storage latch is holding the frame securely in the storage position.
  24. Inspect and properly tighten all parts of the treadmill regularly.
  25. Never insert or drop any object into any opening on the treadmill.
  26. **DANGER:** Always unplug the power cord immediately after use, before cleaning the treadmill, and before performing the maintenance and adjustment procedures described in this manual. Never remove the motor hood unless instructed to do so by an authorized service representative. Servicing other than the procedures in this manual should be performed by an authorized service representative only.
  27. The treadmill is intended for in-home use only. Do not use the treadmill in any commercial, rental, or institutional setting.
  28. To protect the treadmill and TV during lightning storms, unplug the power cord from the wall outlet and disconnect the cable system. This will prevent damage due to lightning and power line surges.
  29. To reduce the risk of electric shock, do not remove the cover or the back of the television. There are no user serviceable parts inside. Refer servicing to qualified service personnel.
  30. Upon completion of any service or repairs to the treadmill or the television, ask the service technician to perform safety checks to confirm that the unit is in proper operating condition.
- Note to CATV system installer: This reminder is provided to call the CATV system installer's attention to Article 820-40 of the NEC that provides guidelines for proper grounding and, in particular, specifies that the cable ground shall be connected to the grounding system of the building, as close to the point of cable entry as practical.

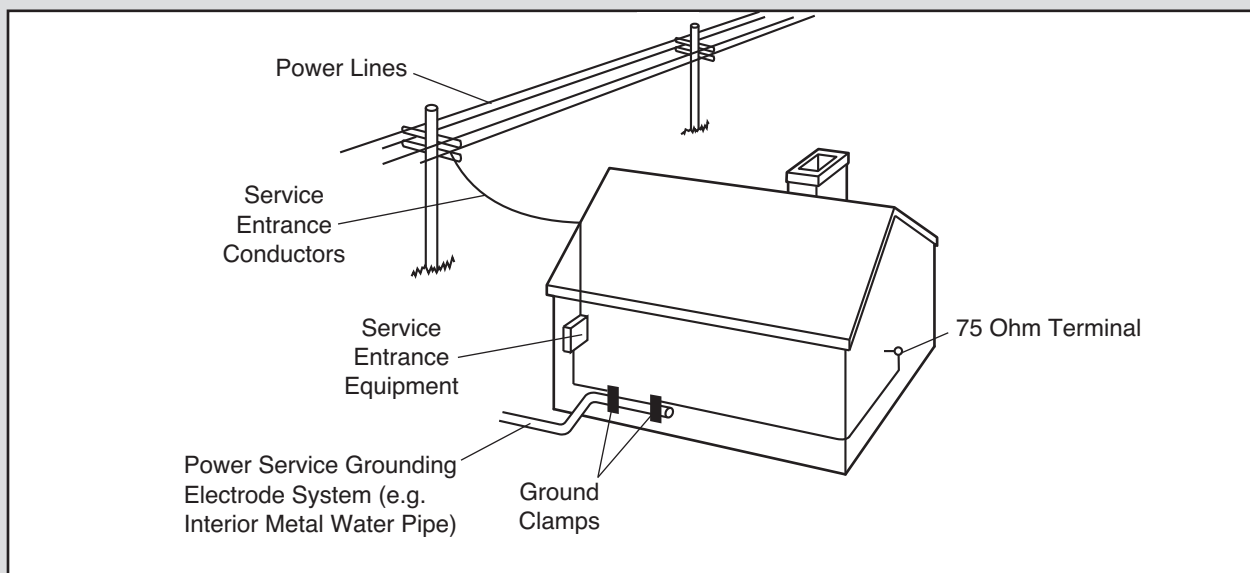

**SAVE THESE INSTRUCTIONS**

# BEFORE YOU BEGIN

Thank you for selecting the revolutionary NordicTrack® ELITE 7500 treadmill. The ELITE 7500 treadmill offers an impressive selection of features designed to make your workouts at home more enjoyable and effective. And when you're not exercising, the unique ELITE 7500 treadmill can be folded up, requiring less than half the floor space of other treadmills.

**For your benefit, read this manual carefully before using the treadmill.** If you have questions after read-

ing this manual, please see the front cover of this manual. To help us assist you, note the product model number and serial number before contacting us. The model number and the location of the serial number decal are shown on the front cover of this manual.

Before reading further, please look at the drawing below and familiarize yourself with the labeled parts.

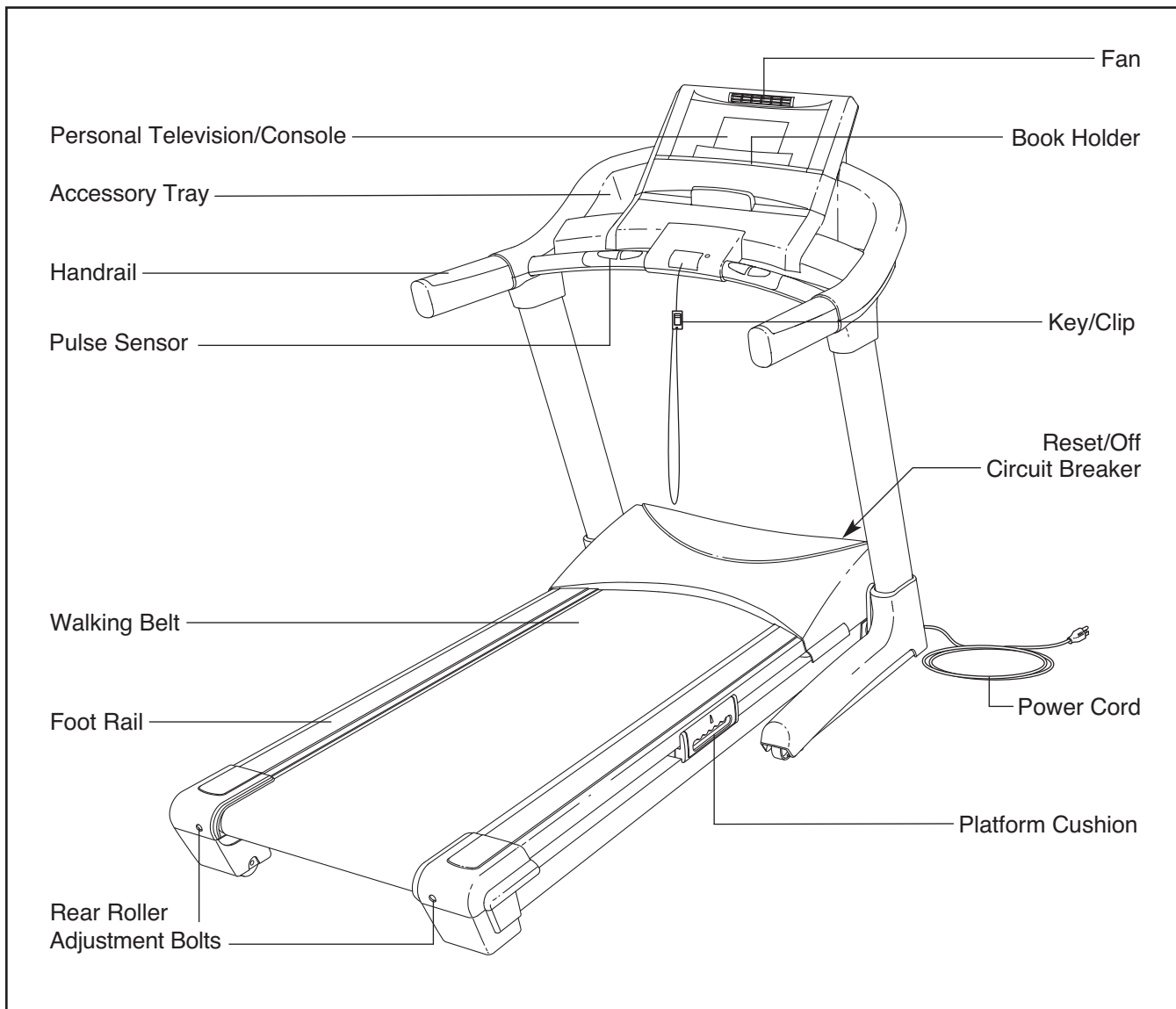

# ASSEMBLY

**Assembly requires two persons.** Set the treadmill in a cleared area and remove all packing materials. **Do not dispose of the packing materials until assembly is completed.** Note: The underside of the treadmill walking belt is coated with high-performance lubricant. During shipping, a small amount of lubricant may be transferred to the top of the walking belt or the shipping carton. This is a normal condition and does not affect treadmill performance. If there is lubricant on top of the walking belt, simply wipe off the lubricant with a soft cloth and a mild, non-abrasive cleaner.

**Assembly requires the included hex key  and your own Phillips screwdriver .**

Use the drawings below to identify the assembly hardware. The number in parentheses below each drawing is the key number of the part, from the PART LIST near the end of this manual. The number after the parentheses is the quantity needed for assembly. **Note: If a part is not in the hardware kit, check to see if it is preattached to one of the parts to be assembled. To avoid damaging plastic parts, do not use power tools for assembly. Extra hardware may be included.**

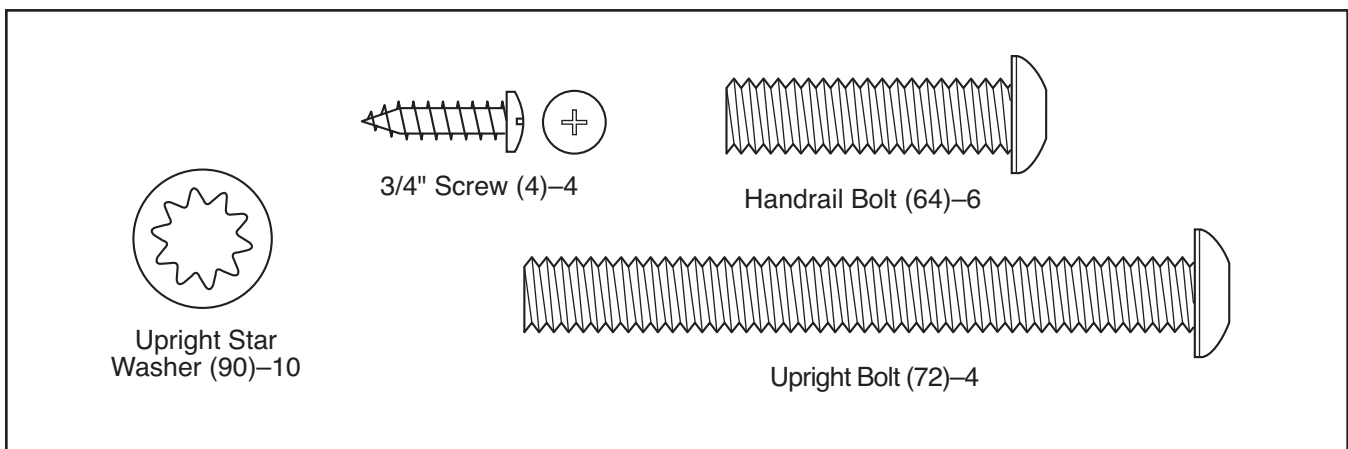

## 1. Make sure that the power cord is unplugged.

With the help of a second person, raise the front of the treadmill and insert the crossbar on the Base (83) into the cutout in the cardboard stand as shown. **Serious injury may occur if the treadmill moves forward or backward and falls off the cardboard stand. A second person must hold the treadmill until assembly step 2 is completed to prevent the treadmill from moving, tipping, or falling.**

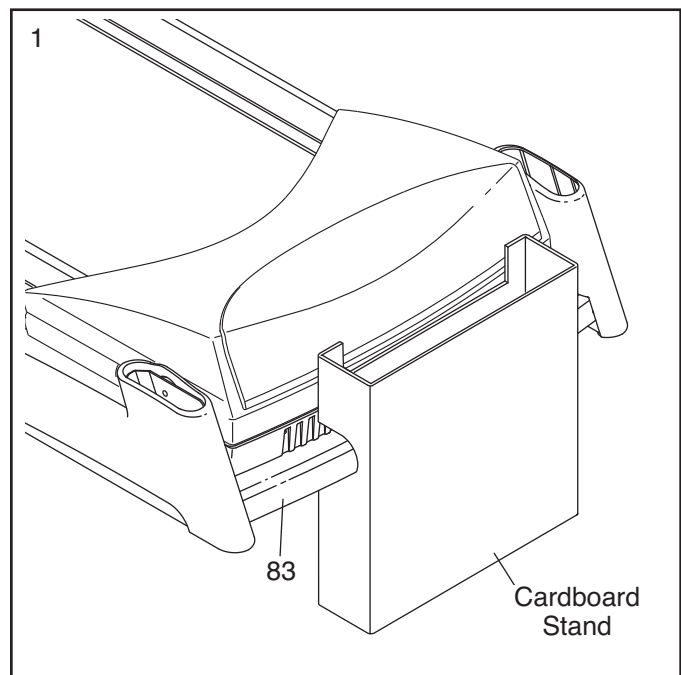

- Identify the Right Upright (74) and the Left Upright (73). **See the inset drawing.** Tie the lower end of the wire tie in the Right Upright securely around the end of the Upright Wire Harness (75). Have a second person hold the Right Upright near the Right Base Cover (77). Then, pull the other end of the wire tie up through the rectangular hole in the bottom of the Right Upright until the Upright Wire Harness is routed completely through the Right Upright.

Gently pull up on the Upright Wire Harness (75) as you set the Right Upright (74) on the Base (83) inside the Right Base Cover (77). **Be careful not to pinch the Upright Wire Harness.**

Attach the Right Upright (74) to the Base (83) with two Upright Bolts (72) and two Upright Star Washers (90). **Do not tighten the Upright Bolts yet.** Note: It may be necessary to tip the tops of the Uprights forward slightly as you thread the Upright Bolts into the Uprights.

Hold the Left Upright (73) near the Left Base Cover (76). Pull the TV Cable (49) and the AV Wire (97) up through the rectangular hole in the bottom of the Left Upright and out of the top of the Left Upright. Set the Left Upright on the Base (83) inside the Left Base Cover. Attach the Left Upright to the Base with two Upright Bolts and two Upright Star Washers (not shown). **Do not tighten the Upright Bolts yet.**

With the help of a second person, lower the treadmill off the cardboard stand.

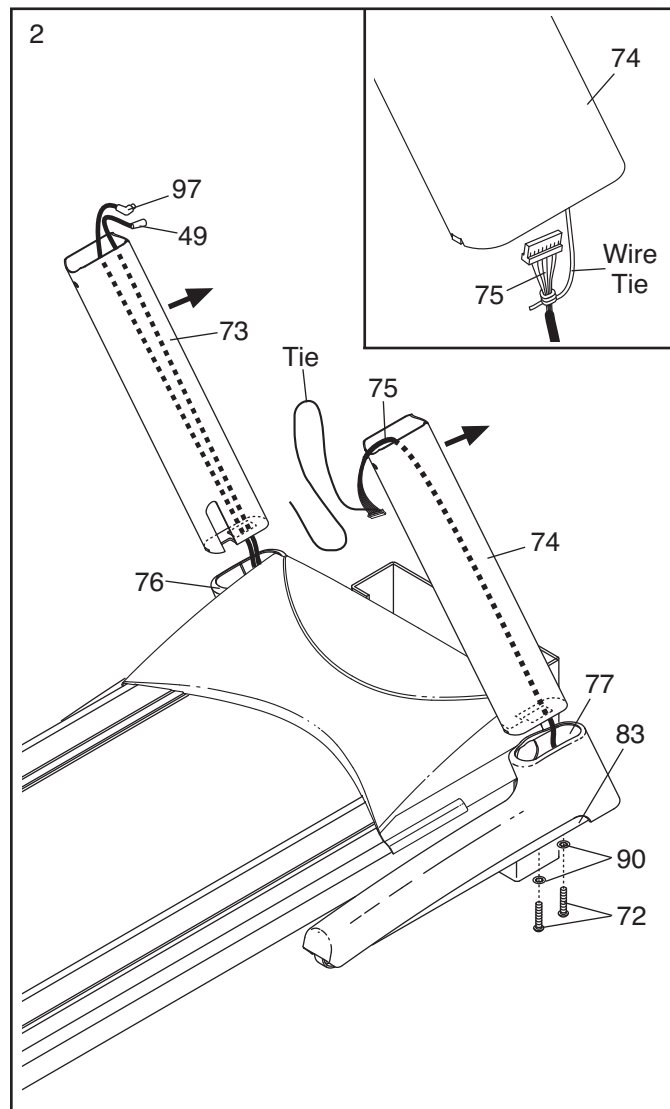

- Identify the Right Upright Sleeve (96) and the Left Upright Sleeve (95); the Upright Sleeves are labeled. Slide the Right Upright Sleeve onto the Right Upright (74) and the Left Upright Sleeve onto the Left Upright (73).

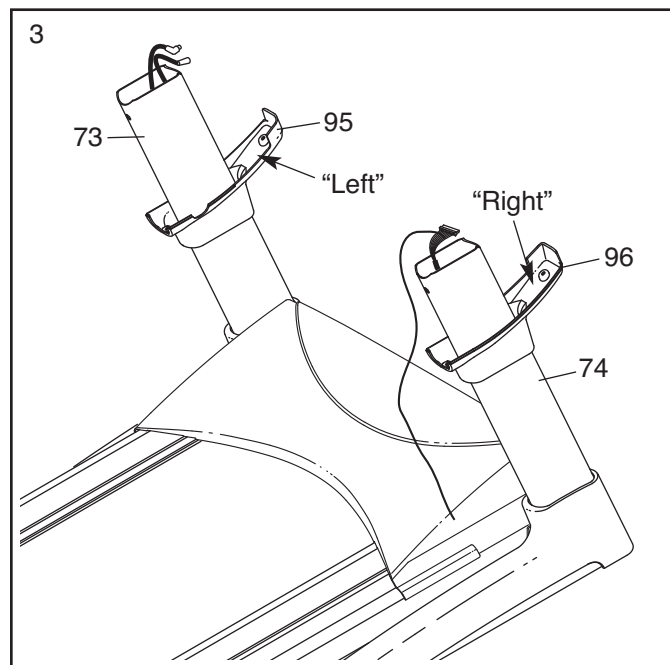

4. With the help of a second person, hold the console assembly near the Uprights (73, 74).

Connect the Upright Wire Harness (75) to the Console Wire Harness (71). **See the inset drawing. The connectors should slide together easily and snap into place.** If they do not, turn one connector and try again. **IF THE CONNECTORS ARE NOT CONNECTED PROPERLY, THE CONSOLE MAY BE DAMAGED WHEN THE POWER IS TURNED ON.** Remove the wire tie from the Upright Wire Harness.

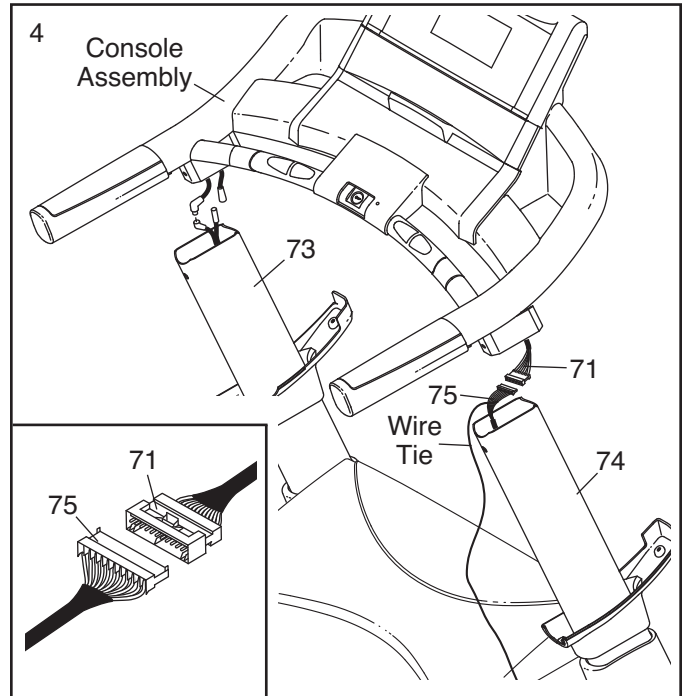

5. Connect the TV Cable (49) and the AV Wire (97) to the cables extending from the console assembly. Then, insert the connectors down into the Uprights (73, 74).

Next, insert the brackets on the Handrails (99) into the Uprights (73, 74). **Make sure that no wires are pinched.**

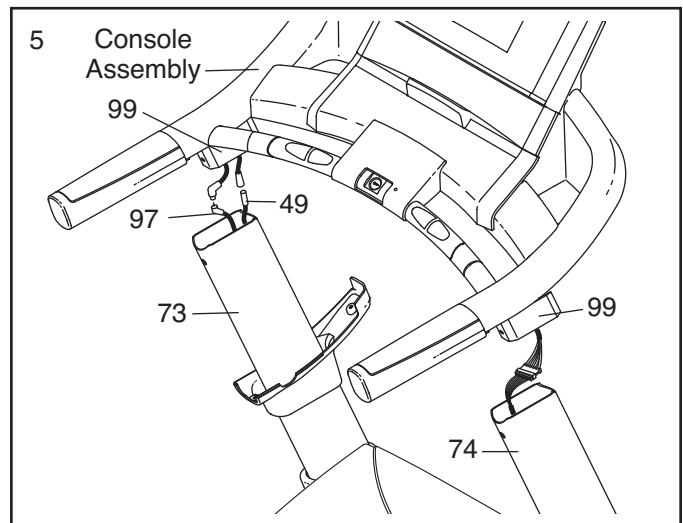

6. Finger tighten three Handrail Bolts (64) with three Upright Star Washers (90) into the Right Upright (74). Next, finger tighten three Handrail Bolts with three Upright Star Washers (not shown) into the Left Upright (73). Then, firmly tighten the six Handrail Bolts.

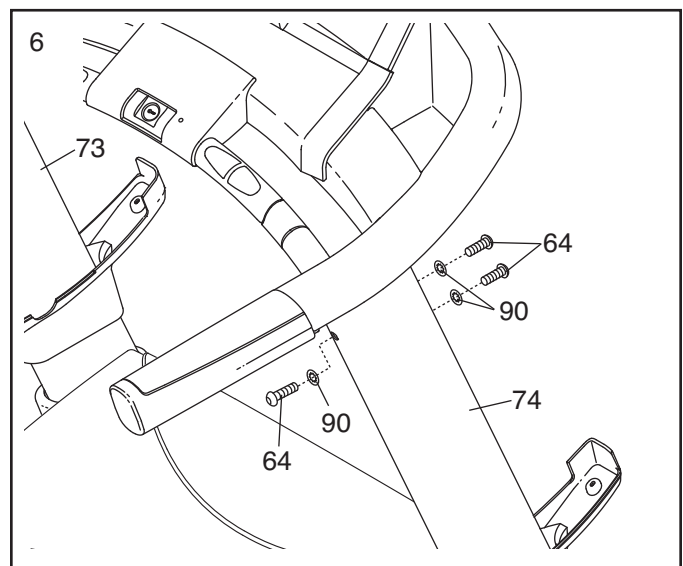

7. Slide the Right Upright Sleeve (96) up against the console assembly. Attach the Right Upright Sleeve with two 3/4" Screws (4).

**Attach the Left Upright Sleeve (not shown) to the console assembly in the same way.**

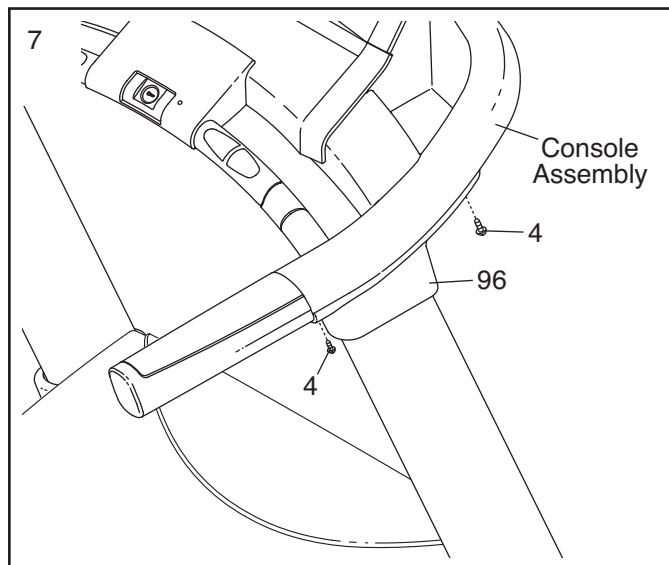

8. With the help of a second person, raise the front of the treadmill and insert the crossbar on the Base (83) into the cutout in the cardboard stand as shown. **Have the second person hold the treadmill to prevent it from moving forward or backward.**

Firmly tighten the four Upright Bolts (72).

With the help of a second person, lower the treadmill off the cardboard stand.

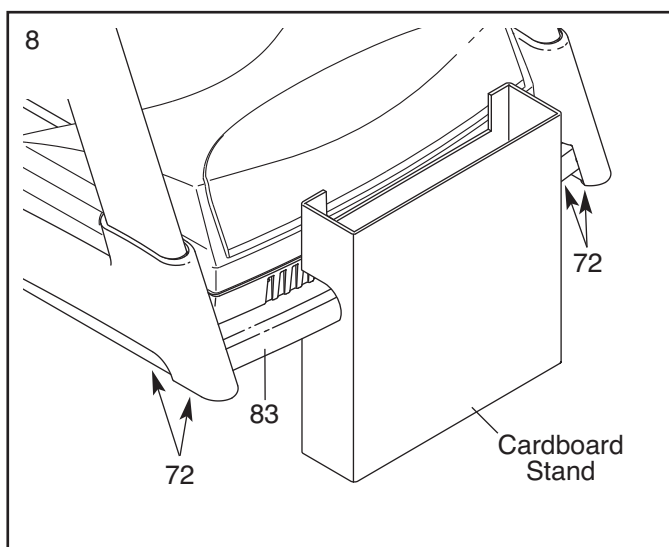

9. Note the location of the 75 ohm terminal and the audio/video input jack on the treadmill. For the television to operate, the Audio/Video Wire Harness (115) must be connected to the audio/video input jack on the treadmill or a CATV cable must be connected to the 75 ohm terminal (see page 10).

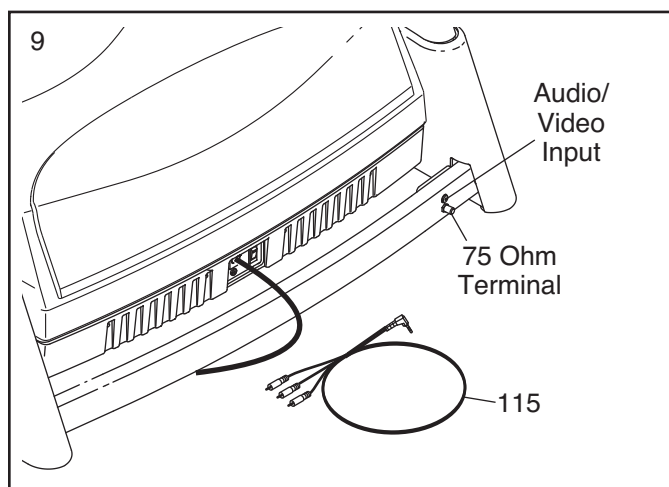

10. **Make sure that all parts are properly tightened before you use the treadmill.** Keep the included hex key in a secure place; the hex key is used to adjust the walking belt (see page 27). **To protect the floor or carpet from damage, place a mat under the treadmill.**

**Before operating the television, you must connect a 75 ohm CATV cable to the 75 ohm terminal on the treadmill or a VCR or DVD player to the audio/video input jacks.** Note: Use a CATV cable to connect to an external source such as a cable box, satellite TV box, VCR, or analog cable. No CATV cable is included.

### HOW TO CONNECT A 75 OHM CATV CABLE

Connect a 75 ohm CATV cable to the 75 ohm terminal on the treadmill frame near the power cord.

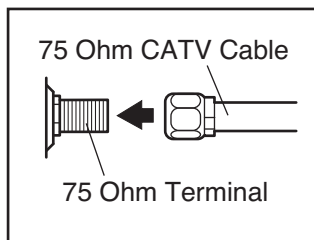

### HOW TO CONNECT A DVD PLAYER OR VCR USING THE AUDIO/VIDEO INPUT JACK

1. Connect the three-pronged end of the included Audio/Video Wire Harness (115) to your DVD player or VCR.

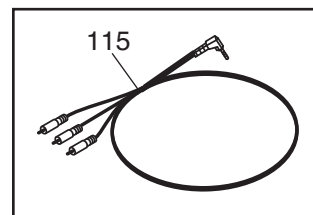

### HOW TO CONNECT AN EXTERNAL SOURCE USING A CATV CABLE

1. Connect one end of a 75 ohm CATV cable to the 75 ohm output jack on your external source.
2. Plug in the power cord of your external source. See your external source user's manual for proper grounding instructions.
3. Connect the 75 ohm CATV cable to the 75 ohm terminal on the treadmill frame near the power cord.

2. Plug in the power cord of your DVD player or VCR. See your DVD player or VCR user's manual for proper grounding instructions.
3. Connect the Audio/Video Wire Harness to the audio/video input jack on the treadmill frame near the power cord.

# HOW TO USE THE CHEST PULSE SENSOR

## HOW TO PUT ON THE CHEST PULSE SENSOR

The chest pulse sensor consists of two components—the chest strap and the sensor unit.

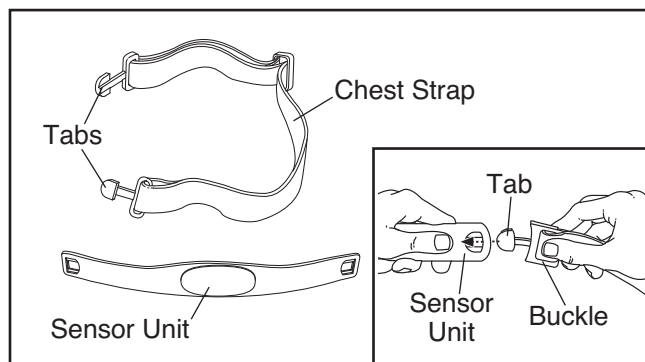

Insert the tab on one end of the chest strap into the hole in one end of the sensor unit, as shown in the inset drawing above. The tab should be flush with the front of the sensor unit.

Next, wrap the chest pulse sensor around your chest and attach the other end of the chest strap to the sensor unit. Adjust the length of the chest strap, if necessary. The chest pulse

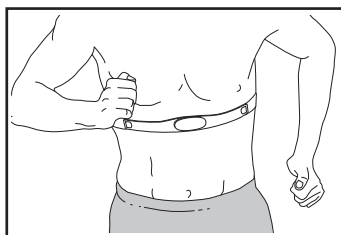

sensor should be under your clothes, tight against your skin, and as high under the pectoral muscles or breasts as is comfortable. Make sure that the logo on the sensor unit is facing forward and is right-side-up.

Pull the sensor unit away from your body a few inches and locate the two electrode areas on the inner side (the electrode areas are covered by shallow ridges). Using saline solution such as saliva or contact lens solution, wet both electrode areas. Return the sensor unit to a position against your chest.

## CHEST PULSE SENSOR CARE AND MAINTENANCE

- Thoroughly dry the chest pulse sensor after each use. The chest pulse sensor is activated when the electrode areas are wetted and the heart rate monitor is put on; the chest pulse sensor shuts off when it is removed and the electrode areas are

dried. If the chest pulse sensor is not dried after each use, it may remain activated longer than necessary, draining the battery prematurely.

- Store the chest pulse sensor in a warm, dry place. Do not store the chest pulse sensor in a plastic bag or other container that may trap moisture.
- Do not expose the chest pulse sensor to direct sunlight for extended periods of time; do not expose it to temperatures above 122° F (50° C) or below 14° F (-10° C).
- Do not excessively bend or stretch the sensor unit when using or storing the chest pulse sensor.
- Clean the sensor unit using a damp cloth—never use alcohol, abrasives, or chemicals. The chest strap may be hand washed and air dried.

## CHEST PULSE SENSOR TROUBLESHOOTING

The instructions on the following pages explain how the chest pulse sensor is used with the console. If the chest pulse sensor does not function properly, try the steps below.

- Make sure that you are wearing the chest pulse sensor as described at the left. Note: If the chest pulse sensor does not function when positioned as described, move it slightly lower or higher on your chest.
- Use saline solution such as saliva or contact lens solution to wet the two electrode areas on the sensor unit. If heart rate readings do not appear until you begin perspiring, rewet the electrode areas.
- As you walk or run on the treadmill, position yourself near the center of the walking belt. **For the console to display heart rate readings, the user must be within arm's length of the console.**
- The chest pulse sensor is designed to work with people who have normal heart rhythms. Heart rate reading problems may be caused by medical conditions such as premature ventricular contractions (pvc's), tachycardia bursts, and arrhythmia.
- The operation of the chest pulse sensor can be affected by magnetic interference caused by high power lines or other sources. If it is suspected that this is a problem, try relocating the treadmill.

# OPERATION AND ADJUSTMENT

## THE PRE-LUBRICATED WALKING BELT

Your treadmill features a walking belt coated with high-performance lubricant. **IMPORTANT: Never apply silicone spray or other substances to the walking belt or the walking platform. Such substances will deteriorate the walking belt and cause excessive wear.**

## HOW TO PLUG IN THE POWER CORD

**⚠ DANGER:** Improper connection of the equipment-grounding conductor can result in an increased risk of electric shock. Check with a qualified electrician or serviceman if you are in doubt as to whether the product is properly grounded. Do not modify the plug provided with the product—if it will not fit the outlet, have a proper outlet installed by a qualified electrician.

Your treadmill, like any other type of sophisticated electronic equipment, can be seriously damaged by sudden voltage changes in your home's power. Voltage surges, spikes, and noise interference can result from weather conditions or from other appliances being turned on or off. **To decrease the possibility of your treadmill being damaged, always use a surge suppressor with your treadmill (see drawing 1 at the right).** To purchase a surge suppressor, see your local NordicTrack dealer or call the telephone number on the front cover of this manual and order part number 146148, or see your local electronics store.

Use only a single-outlet surge suppressor that is UL 1449 listed as a transient voltage surge suppressor (TVSS). The surge suppressor must have a UL suppressed voltage rating of 400 volts or less and a minimum surge dissipation of 450 joules. The surge suppressor must be electrically rated for 120 volts AC and 15 amps. There must be a monitoring light on the surge suppressor to indicate whether it is functioning properly. Failure to use a properly functioning surge suppressor could result in damage to the control system of the treadmill. If the control system is damaged, the walking belt may slow, accelerate, or stop unexpectedly, which may result in a fall and serious injury.

**This product must be grounded.** If it should malfunction or break down, grounding provides a path of least resistance for electric current to reduce the risk of elec-

tric shock. This product is equipped with a cord having an equipment-grounding conductor and a grounding plug. **Plug the power cord into a surge suppressor, and plug the surge suppressor into an appropriate outlet that is properly installed and grounded in accordance with all local codes and ordinances. IMPORTANT: The treadmill is not compatible with GFCI-equipped outlets.**

This product is for use on a nominal 120-volt circuit, and has a grounding plug that looks like the plug illustrated in drawing 1 below. A temporary adapter that looks like the adapter illustrated in drawing 2 may be used to connect the surge suppressor to a 2-pole receptacle as shown in drawing 2 if a properly grounded outlet is not available.

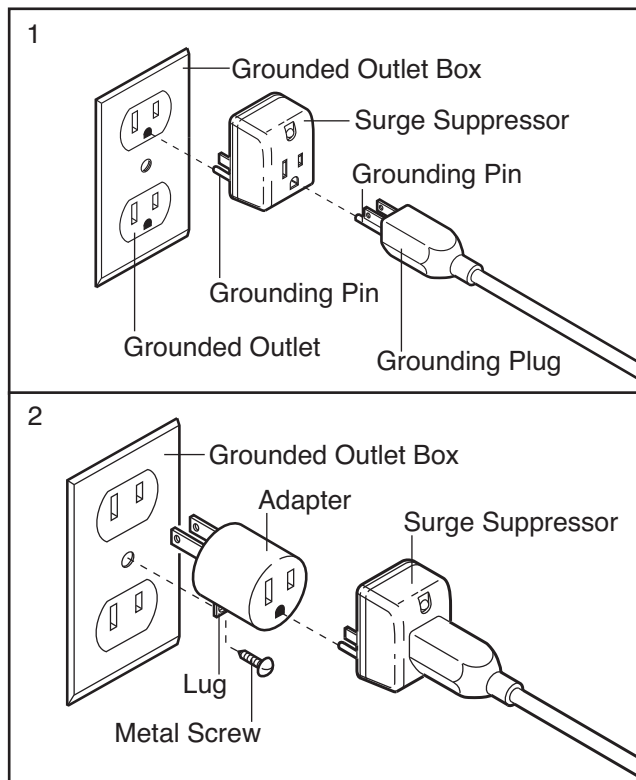

The temporary adapter should be used only until a properly grounded outlet (drawing 1) can be installed by a qualified electrician.

The green-colored rigid ear, lug, or the like extending from the adapter must be connected to a permanent ground such as a properly grounded outlet box cover. Whenever the adapter is used it must be held in place by a metal screw. **Some 2-pole receptacle outlet box covers are not grounded. Contact a qualified electrician to determine if the outlet box cover is grounded before using an adapter.**

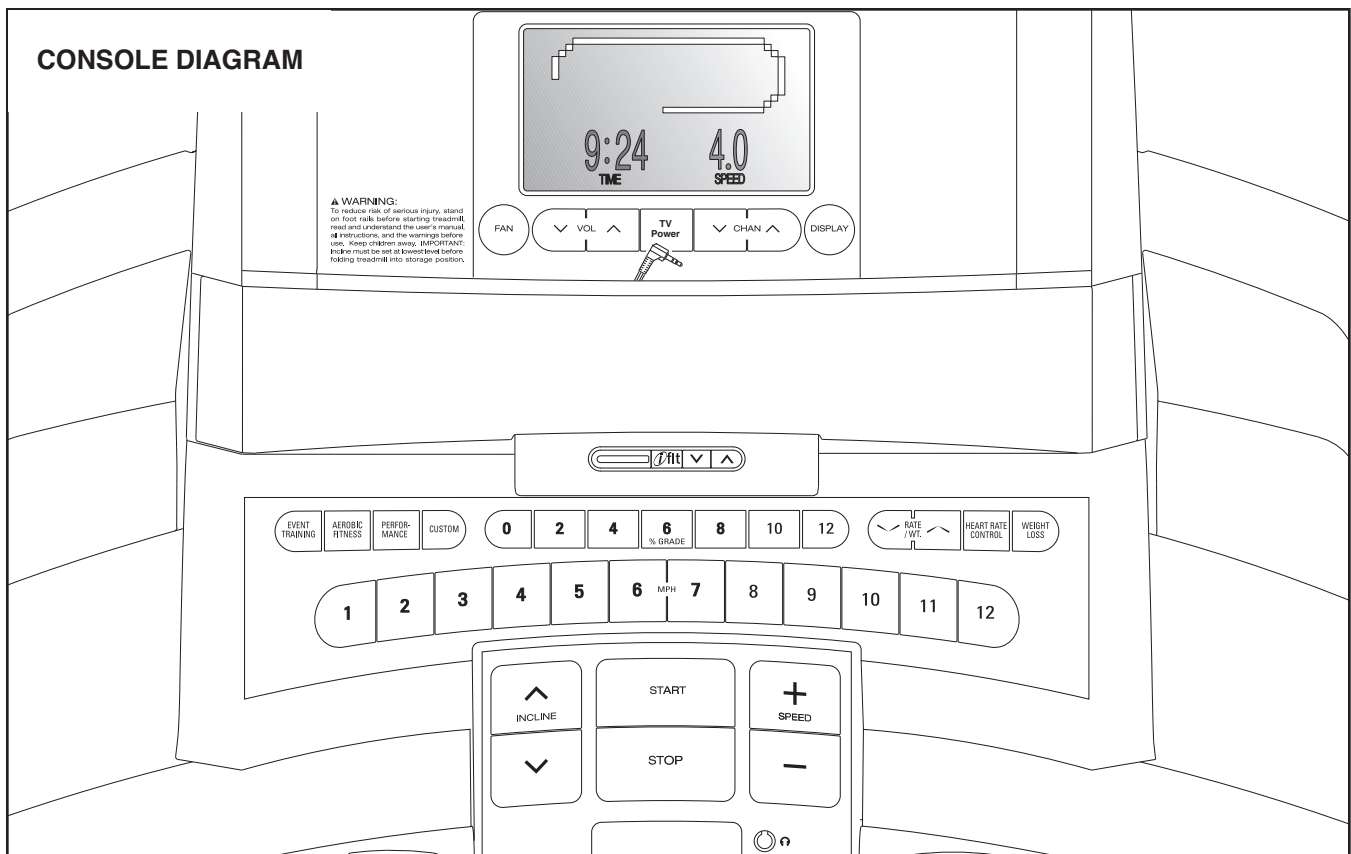

## FEATURES OF THE CONSOLE

The treadmill console offers an impressive array of features designed to make your workouts more effective and enjoyable. When the manual mode of the console is selected, the speed and incline of the treadmill can be changed with the touch of a button. As you exercise, the screen will display continuous exercise feedback. You can even measure your heart rate using the handgrip pulse sensor or the chest pulse sensor.

The console also offers four event training workouts. Each workout counts down the distance as you complete a 5-kilometer, 10-kilometer, half marathon, or full marathon run.

In addition, the console features twenty-three preset workouts—eight Aerobic Fitness workouts, seven Performance workouts, and eight Weight Loss workouts. Each workout automatically controls the speed and incline of the treadmill as it guides you through an effective workout. You can even create your own custom workouts and save them for future use.

The console also features the new iFit interactive workout system. The iFit system enables the console to accept iFit interactive workout cards containing workouts designed to help you achieve specific fitness goals. For example, lose unwanted pounds with the 8-week

Weight Loss workout, or train for a long-distance run with the Marathon workout. iFit workouts automatically control the treadmill while the voice of a personal trainer coaches you and motivates you through every step of your workout. One iFit card is included. Additional iFit cards are available separately. **To purchase iFit cards at any time, see the front cover of this manual or go to [www.iFit.com](http://www.iFit.com). iFit cards are also available at select stores.**

The console also offers four heart rate workouts that control the speed and incline of the treadmill to help you keep your heart rate near target heart rate settings.

Whether you select the manual mode or a workout, you can enjoy the shows of your choice on the personal television while you get in shape. You can also listen to your favorite workout music or audio books with the console's premium sound system.

**To turn on the power**, see page 14. **To use the manual mode**, see page 14. **To use an event training workout**, see page 16. **To use a preset workout**, see page 17. **To create and use a custom workout**, see pages 18 and 19. **To use an iFit card**, see page 20. **To use a heart rate workout**, see page 21. **To operate the personal television**, see page 22. **To use the information mode**, see page 23. **To use the sound system**, see page 24.

## HOW TO TURN ON THE POWER

**IMPORTANT:** If the treadmill has been exposed to cold temperatures, allow it to warm to room temperature before turning on the power. If you do not do this, the console displays or other electrical components may become damaged.

Plug in the power cord (see page 12). Next, locate the reset/off circuit breaker on the treadmill frame near the power cord. Make sure that the circuit breaker is in the “reset” position.

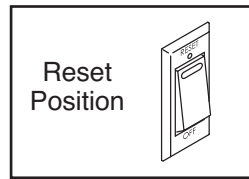

**IMPORTANT:** The console features a display demo mode, designed to be used if the treadmill is displayed in a store. If the screen lights as soon as you plug in the power cord and switch the reset/off circuit breaker to the reset position, the demo mode is turned on. To turn off the demo mode, hold down the Stop button for a few seconds. If the screen remains lit, see THE INFORMATION MODE on page 23 to turn off the demo mode.

Next, stand on the foot rails of the treadmill. Locate the clip attached to the key (see the drawing at the right), and slide the clip securely onto the waistband of your clothes. Then, insert the key into the console.

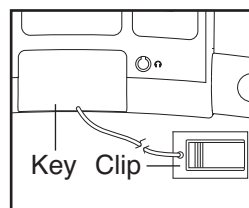

After a moment, the screen will light. **IMPORTANT:** In an emergency situation, the key can be pulled from the console, causing the walking belt to slow to a stop. Test the clip by carefully taking a few steps backward; if the key is not pulled from the console, adjust the position of the clip.

**IMPORTANT:** If there is a sheet of clear plastic on the face of the console, remove the plastic. To prevent damage to the walking platform, wear clean athletic shoes while using the treadmill. The first time the treadmill is used, observe the alignment of the walking belt, and center the walking belt if necessary (see page 27).

Note: The console can display speed and distance in either miles or kilometers. To find out which unit of measurement is selected or to change the unit of measurement, see THE INFORMATION MODE on page 23. For simplicity, all instructions in this section refer to miles

## HOW TO USE THE MANUAL MODE

### 1. Insert the key into the console.

See HOW TO TURN ON THE POWER at the left.

### 2. Select the manual mode.

Each time the key is inserted, the manual mode will be selected. If you have selected a workout, press any of the workout buttons

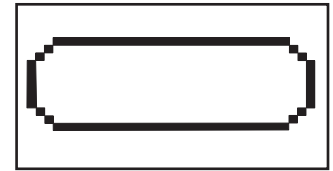

(Event Training, Aerobic Fitness, Performance, Custom, Heart Rate Control, or Weight Loss) repeatedly until a track appears on the screen.

### 3. Start the walking belt and adjust the speed.

To start the walking belt, press the Start button, the Speed increase button, or one of the speed buttons numbered 1 to 12.

If you press the Start button or the Speed increase button, the walking belt will begin to move at 1 mph. As you exercise, change the speed of the walking belt as desired by pressing the Speed increase and decrease buttons. Each time you press a button, the speed setting will change by 0.1 mph; if you hold down the button, the speed setting will change in increments of 0.5 mph. If you press one of the numbered speed buttons, the walking belt will gradually change speed until it reaches the selected speed setting.

To stop the walking belt, press the Stop button. To restart the walking belt, press the Start button, the Speed increase button, or one of the numbered speed buttons.

### 4. Change the incline of the treadmill as desired.

To change the incline of the treadmill, press the Incline increase and decrease buttons or one of the incline buttons numbered 0 to 12.

Each time you press the Incline increase or decrease button, the incline will change by 0.5%. If you press one of the numbered incline buttons, the incline will gradually change until it reaches the selected incline setting.

## 5. Select a display mode and follow your progress with the exercise information on the screen.

As you walk or run on the treadmill, the screen can display the following exercise information:

- The elapsed time. Note: When a workout is selected, the screen will show the time remaining in the workout instead of the elapsed time.
- The distance that you have walked or run.
- The speed of the walking belt.
- The approximate number of calories that you have burned.
- The incline level of the treadmill. Note: The incline level of the treadmill will be displayed only when you press the Incline buttons.
- Your heart rate. Note: Your heart rate will be displayed only when you use the handgrip pulse sensor or the chest pulse sensor.
- When the manual mode is selected, the screen can show a track that represents 1/4 mile (400 meters). As you walk or run on the treadmill, the indicators around the track will appear in succession until the entire track appears. The track will then disappear and the indicators will again begin to appear in succession.

While the television is off, you can select either of two display modes—a track and some of the exercise information, or all of the exercise information. While the television is on, you can select any of three display modes—the information can be displayed on the right side of the screen, on the bottom of the screen, or the information can be turned off while you watch the television. Press the Display button repeatedly to select the desired display mode.

To reset the console, press the Stop button, remove the key, and then reinsert the key.

## 6. Measure your heart rate if desired.

**Note: If you use the handgrip pulse sensor and the chest pulse sensor at the same time, the console will not display your heart rate accurately.** See page 11 for more information about the chest pulse sensor.

Before using the handgrip pulse sensor, remove the sheets of clear plastic from the metal contacts. In addition, make sure that your hands are clean.

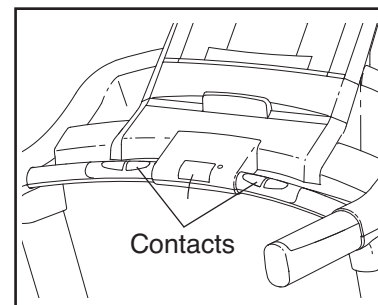

To measure your heart rate, **stand on the foot rails** and hold the metal contacts on the handrail—**avoid moving your hands. Hold the contacts for approximately ten seconds.** When your pulse is detected, your heart rate will be shown. **For the most accurate heart rate reading, continue to hold the contacts for about 15 seconds.**

## 7. Turn on the fan if desired.

The fan features low and high speed settings. Press the Fan button repeatedly to select a fan speed or to turn off the fan. Note: If the fan is on when the walking belt is stopped, the fan will turn off automatically after a few minutes.

## 8. When you are finished exercising, remove the key from the console.

Step onto the foot rails, press the Stop button, and **adjust the incline of the treadmill to the lowest setting. The incline must be at the lowest setting when you fold the treadmill to the storage position, or you may damage the treadmill.** Next, remove the key from the console and put it in a secure place.

When you are finished using the treadmill, switch the reset/off circuit breaker to the “off” position and unplug the power cord. **IMPORTANT: If you do not do this, the treadmill’s electrical components may wear prematurely.**

## HOW TO USE AN EVENT TRAINING WORKOUT

### 1. Insert the key into the console.

See HOW TO TURN ON THE POWER on page 14.

### 2. Select an event training workout.

To select an event training workout, press the Event Training button repeatedly; the name of the workout (5 kilometer, 10 kilometer, Half Marathon, or Full Marathon) and a track will appear on the screen.

### 3. Press the Start button to start the workout.

A moment after you press the button, the walking belt will begin to move at 4 mph. Hold the handrails and begin walking.

After several minutes, the speed setting will flash on the screen and a series of tones will sound. The speed of the walking belt will then increase to 5 mph.

After another minute, the speed setting will flash on the screen and a series of tones will sound. The speed of the walking belt will then increase to 6.5 mph.

Note: To change the speed of the walking belt or the incline of the treadmill at any time during the workout, press the speed or incline buttons.

During an event training workout, the screen will show the number of miles or kilometers still to be walked or run.

To stop the workout at any time, press the Stop button. To restart the workout, press the Start button. The walking belt will begin to move at 1 mph. Adjust the speed of the walking belt as desired by pressing the Speed increase or decrease button or one of the numbered speed buttons.

Note: When you have completed an event, your total time and the words "Cool Down" will appear on the screen. If the speed of the walking belt was greater than 5 mph when you completed the event, the walking belt will then slow to 5 mph for one minute. After one minute, the walking belt will slow to 4 mph for 2 minutes. The walking belt will then slow to 3 mph for 2 minutes. The walking belt will then slow to a stop.

### 4. Select a display mode and follow your progress with the exercise information on the screen.

See step 5 on page 15.

### 5. Measure your heart rate if desired.

See step 6 on page 15.

### 6. Turn on the fan if desired.

See step 7 on page 15.

### 7. When you are finished exercising, remove the key from the console.

See step 8 on page 15.

## HOW TO USE A PRESET WORKOUT

### 1. Insert the key into the console.

See HOW TO TURN ON THE POWER on page 14.

### 2. Select a preset workout.

To select a preset workout, press the Aerobic Fitness button, the Performance button, or the Weight Loss button repeatedly.

When a preset workout is selected, the screen will show the maximum speed setting, the maximum incline setting, and the duration of the workout. In addition, a profile of the workout intensity settings will be displayed. The arrow below the profile will indicate your progress during your workout.

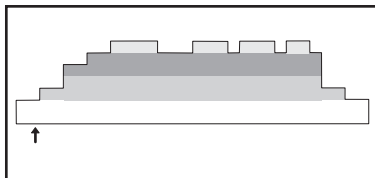

Note: When a weight loss workout is selected, the screen will also show the calorie goal for the workout. **IMPORTANT: The calorie goal is an estimate of the number of calories that you will burn during the workout. The actual number of calories that you burn will depend on your weight. In addition, if you manually change the speed or incline of treadmill during the workout, the number of calories you burn will be affected.**

### 3. Enter your weight.

For the most accurate calorie count, enter your weight by pressing the Rate/Wt. increase and decrease buttons repeatedly. Note: Once you have entered your weight, it will be saved in memory.

### 4. Press the Start button to start the workout.

A moment after you press the Start button, the treadmill will automatically adjust to the first speed and incline settings of the workout. Hold the handrails and begin walking.

Each workout is divided into several one-minute segments. One speed setting and one incline setting are programmed for each segment. Note: The same speed and/or incline setting may be programmed for consecutive segments.

When only three seconds remain in the first segment of the workout, a series of tones will sound. If the speed and/or the incline of the treadmill is about to change, the new speed and/or incline setting will appear on the screen to alert you. When the first segment ends, the arrow below the workout profile will move one position to the right. Note: The workout profile can be displayed only when the television is in Console/MP3 mode. To select the Console/MP3 mode, press the TV Power button repeatedly until the word "MP3" appears on the screen.

When the first segment ends, the treadmill will automatically adjust to the speed and incline settings for the second segment.

The workout will continue in this way until the arrow reaches the right end of the workout profile. The walking belt will then slow to a stop.

If the speed and/or incline settings of the workout are too high or too low, you can override the setting by pressing the speed or incline buttons; **however, when the next segment begins, the treadmill will automatically adjust to the speed and incline settings for the next segment.**

To stop the workout at any time, press the Stop button. To restart the workout, press the Start button. The walking belt will begin to move at 1 mph. When the next segment of the workout begins, the treadmill will automatically adjust to the speed and incline settings for the next segment.

### 5. Select a display mode and follow your progress with the exercise information on the screen.

See step 5 on page 15.

### 6. Measure your heart rate if desired.

See step 6 on page 15.

### 7. Turn on the fan if desired.

See step 7 on page 15.

### 8. When you are finished exercising, remove the key from the console.

See step 8 on page 15.

## HOW TO CREATE A CUSTOM WORKOUT

### 1. Insert the key into the console.

See HOW TO TURN ON THE POWER on page 14.

### 2. Select one of the four custom workouts.

To select a custom workout, press the Custom button repeatedly. When a custom workout is selected, the name of the workout (CUSTOM: 1, CUSTOM: 2, CUSTOM: 3, or CUSTOM: 4) will appear on the screen.

**Note: If the custom workout has not yet been designed, a workout time of three minutes will appear on the screen and the profile will have only three segments (see the drawing above). If the workout time is more than three minutes, see HOW TO USE A CUSTOM WORKOUT on page 19.**

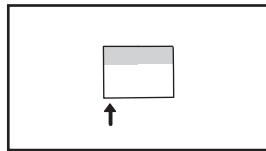

### 3. Press the Start button and program the desired speed and incline settings.

A moment after you press the Start button, the walking belt will begin to move. Hold the handrails and begin walking.

Each custom workout is divided into several one-minute segments. One speed setting and one incline setting can be programmed for each segment. To program a speed setting and an incline

setting for the first segment, simply adjust the speed and incline of the treadmill as desired by pressing the speed and incline buttons.

When the first segment of the workout ends, a series of tones will sound and the current speed setting and the current incline setting will be saved in memory. Program a speed setting and an incline setting for the second segment as described above.

Continue programming speed and incline settings for as many segments as desired; custom workouts can have up to forty segments. When you are finished with your workout, press the Stop button and then the Speed decrease button. The speed and incline settings that you have programmed and the workout time will then be saved in memory.

### 4. Select a display mode and follow your progress with the exercise information on the screen.

See step 5 on page 15.

### 5. Measure your heart rate if desired.

See step 6 on page 15.

### 6. Turn on the fan if desired.

See step 7 on page 15.

### 7. When you are finished exercising, remove the key from the console.

See step 8 on page 15.

## HOW TO USE A CUSTOM WORKOUT

### 1. Insert the key into the console.

See HOW TO TURN ON THE POWER on page 14.

### 2. Select one of the four custom workouts.

To select a custom workout, press the Custom button repeatedly. When a custom workout is selected, the name of the workout (CUSTOM: 1, CUSTOM: 2, CUSTOM: 3, or CUSTOM: 4) will appear on the screen.

In addition, the maximum speed and incline settings of the workout, the workout time, and a profile of the intensity settings of the workout will appear.

**Note: If the workout time is only three minutes, see HOW TO CREATE A CUSTOM WORKOUT on page 18.**

### 3. Press the Start button to start the workout.

A moment after you press the Start button, the treadmill will automatically adjust to the first speed and incline settings that you programmed previously. Hold the handrails and begin walking.

Each custom workout is divided into several one-minute segments. One speed setting and one incline setting are programmed for each segment. Note: The same speed setting and/or incline setting may be programmed for consecutive segments.

The custom workout will function in the same way as a preset workout (see step 4 on page 17).

If desired, you can redesign the workout while using it. **To change the speed setting or the incline setting for the current segment**, simply press the speed or incline buttons. When the current segment ends, the new setting will be saved in memory. **To increase the length of the workout**, first wait until the workout is completed. Then, press the Start button and program speed and incline settings for as many additional segments as desired. When you have added as many segments as desired, press the Stop button and then the Speed decrease button. **To decrease the length of the workout**, press the Stop button and then the Speed decrease button at any time before the workout is completed.

To stop the workout temporarily, press the Stop button. To restart the workout, press the Start button. The walking belt will begin to move at 1 mph. When the next segment of the workout begins, the treadmill will automatically adjust to the speed and incline settings programmed for the next segment.

### 4. Select a display mode and follow your progress with the exercise information on the screen.

See step 5 on page 15.

### 5. Measure your heart rate if desired.

See step 6 on page 15.

### 6. Turn on the fan if desired.

See step 7 on page 15.

### 7. When you are finished exercising, remove the key from the console.

See step 8 on page 15.

## HOW TO USE AN IFIT CARD

### 1. Insert the key into the console.

See HOW TO TURN ON THE POWER on page 14.

### 2. Insert an iFit card and select a workout.

To use an iFit workout, insert an iFit card into the iFit slot; make sure that the iFit card is oriented so the metal contacts are face-down and are inserted into the iFit slot.

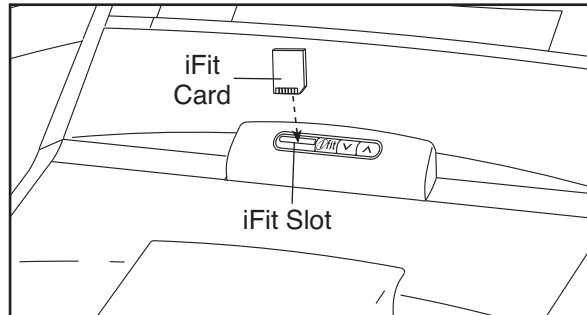

Next, select an iFit workout by pressing the iFit up and down buttons next to the iFit slot. When an iFit workout is selected, the display will show the name of the workout, duration, the maximum incline setting, and the maximum speed setting of the workout. In addition, a profile of the workout intensity settings of the workout will appear in the display.

Each iFit workout is divided into several one-minute segments. One speed setting and one incline setting are programmed for each segment. Note: The same speed and/or incline setting may be programmed for consecutive segments.

### 3. Press the Start button to start the workout.

A moment after you press the Start button, the treadmill will automatically adjust to the first speed

and incline settings of the workout. Hold the handrails and begin walking.

During the workout, a personal trainer will guide you through the workout. You can select an audio setting for your personal trainer (see THE INFORMATION MODE on page 23).

If the speed or incline setting for the current segment is too high or too low, you can manually override the setting by pressing the speed or incline buttons; **however, when the next segment begins, the treadmill will automatically adjust to the speed and incline settings for the next segment.**

To stop the workout at any time, press the Stop button. To restart the workout, press the Start button or the Speed increase button. The walking belt will begin to move at 1 mph. When the next segment of the workout begins, the treadmill will automatically adjust to the speed and incline settings for the next segment.

### 4. Select a display mode and follow your progress with the exercise information on the screen.

See step 5 on page 15.

### 5. Turn on the fan if desired.

See step 7 on page 15.

### 6. When you are finished exercising, remove the key from the console.

See step 8 on page 15.

**CAUTION: Always remove iFit cards from the iFit slot when you are not using them.**

## HOW TO USE A HEART RATE WORKOUT

**CAUTION:** If you have heart problems, or if you are over 60 years of age and have been inactive, do not use the heart rate workouts. If you are taking medication regularly, consult your physician to find whether the medication will affect your exercise heart rate.

Follow the steps below to use a heart rate workout.

### 1. Put on the chest pulse sensor.

Note: For best results, wear the chest pulse sensor to use a heart rate workout. See page 11 for information about the chest pulse sensor.

### 2. Insert the key into the console.

See HOW TO TURN ON THE POWER on page 14.

### 3. Select one of the four heart rate workouts.

To select a heart rate workout, press the Heart Rate Control button repeatedly. When a heart rate workout is selected, the name of the workout (HEART RATE: 1, HEART RATE: 2, HEART RATE: 3, or HEART RATE: 4) will appear on the screen.

**If heart rate workout 1 is selected,** a track will appear on the screen.

**If heart rate workout 2, 3, or 4 is selected,** a profile of the heart rate settings of the workout will appear on the screen. The arrow below the profile will indicate your progress during the workout.

### 4. Enter a target heart rate setting.

**If heart rate workout 1 is selected,** the target heart rate setting for the entire workout will appear on the screen beside the words “Target BPM” (beats per minute). If desired, press the Rate/Wt. increase and decrease buttons to change the target heart rate setting (see EXERCISE INTENSITY on page 29).

**If heart rate workout 2, 3, or 4 is selected,** the maximum target heart rate setting of the workout

will appear on the screen beside the words “Target BPM.” If desired, press the Rate/Wt. increase and decrease buttons to change the maximum target heart rate setting (see EXERCISE INTENSITY on page 29). Note: If you change the maximum target heart rate setting, the intensity level of the entire workout will change.

### 5. Press the Start button to start the workout.

A moment after you press the Start button, the treadmill will automatically adjust to the first speed and incline settings of the workout. Hold the handrails and begin walking.

Heart rate workout 1 is divided into several one-minute segments. The same target heart rate setting is programmed for all segments (except for the first two segments). Heart rate workouts 2, 3, and 4 are divided into 30 one-minute segments. One target heart rate setting is programmed for each segment. Note: The same target heart rate setting may be programmed for consecutive segments.

During each segment of the workout, the console will compare your heart rate to the target heart rate setting for that segment. If your heart rate is too far below or above the target heart rate setting, the speed and/or incline will automatically increase or decrease to bring your heart rate closer to the target heart rate setting. Each time the speed and/or incline of the treadmill is about to change, the speed and/or incline setting will flash on the screen to alert you, regardless of which display mode is selected.

**If heart rate workout 2, 3, or 4 is selected,** a series of tones will sound when the first segment of the workout ends. The arrow below the workout profile will then move one position to the right. The workout will continue in this way until the arrow reaches the right end of the workout profile. The walking belt will then slow to a stop.

If the speed and/or incline settings are too high or too low, you can change the intensity level of the workout at any time by pressing the Speed and Incline buttons; **however, when the console compares your heart rate to the target heart rate for the current segment, the speed and/or incline of the treadmill may change to bring your heart rate closer to the target heart rate setting.**

To stop the workout at any time, press the Stop button. To restart the workout, press the Start button. The walking belt will begin to move at 1 mph; **however, when the console compares your heart rate to the target heart rate setting for the current segment, the speed and/or incline of the treadmill may change to bring your heart rate closer to the target heart rate setting.**

6. **Select a display mode and follow your progress with the exercise information on the screen.**

See step 5 on page 15.

7. **Turn on the fan if desired.**

See step 7 on page 15.

8. **When you are finished exercising, remove the key from the console.**

See step 8 on page 15.

## HOW TO OPERATE THE PERSONAL TELEVISION

**IMPORTANT:** Before operating the television, you must connect a 75 ohm CATV cable to the 75 ohm terminal on the treadmill or a VCR or DVD player to the audio/video input jack. See page 10 for instructions.

Follow the steps below to operate the television.

1. **Insert the key into the console.**

See HOW TO TURN ON THE POWER on page 14.

2. **Press the TV Power button to select a television source or the Console/MP3 mode.**

Select a television source or the Console/MP3 mode by pressing the TV Power button repeatedly.

If you have connected a 75 ohm CATV cable to the 75 ohm terminal on the treadmill, select the Tuner source. If you have plugged a DVD player or VCR into the audio/video input jack, select the RCA source. If you have connected a personal audio player to the audio jack below the television on the console, select the MP4 source. If you do not wish to use the television, select the Console/MP3 mode.

3. **Press the Channel buttons to select the desired cable channel.**

Note: Complete this step only if you are using analog cable. Otherwise, change channels through an external source such as your cable box or your VCR.

When you turn on the television, the screen will show the last cable channel that was selected. To select a different channel, press the Channel (CHAN) buttons. The selected cable channel number will appear on the screen for a few seconds. Note: The television is equipped with a channel memorizing function that allows you to go directly from the current channel to the next channel saved in memory. Before channels can be selected in this way, they must be saved in the television's memory. See THE INFORMATION MODE on page 23.

4. **Press the Volume buttons to adjust the volume.**

Press the Volume (VOL) increase or decrease button to change the volume. When either button is pressed, the volume level indicator will appear on the screen for a few seconds.

To use earphones or headphones (not included), plug them into the headphone jack beside the key on the console.

## THE INFORMATION MODE

The console features an information mode that allows you to view treadmill usage information, select a system of measurement for the console, and turn on and turn off the demo mode. The information mode also allows you to adjust the settings of the television and to save channels into the television's memory.

Follow the steps below to use the information mode.

### 1. Press the Stop button while inserting the key into the console.

When the information mode is selected, the lower part of the screen will show the total number of miles or kilometers that the walking belt has moved (Distance) and the total number of hours that the treadmill has been used (Time).

In addition, the center of the display will show the word "English" for English miles or the word "Metric" for metric kilometers. Press the Speed increase button to change the unit of measurement if desired.

Note: The console features a display demo mode, designed to be used if the treadmill is displayed in a store. While the demo mode is turned on, the console will function normally when you plug in the power cord, switch the reset/off circuit breaker to the reset position, and insert the key into the console. However, when you remove the key, the displays will remain lit, although the buttons will not function. If the demo mode is turned on, the words "DEMO ON" will appear on the screen while the information mode is selected. To turn on or turn off the demo mode, press the Speed decrease button until the words "DEMO OFF" appear on the screen.

While the information mode is selected, you can select an audio setting for the iFit personal trainer, if desired. If you select the All setting, the personal trainer will give you detailed instructions to help you through your workout. If you select the On setting, the personal trainer will simply guide you through the workout. If you select the Off setting, the personal trainer will be silent. To select a personal trainer audio setting, press the incline increase or decrease button.

### 2. Press the TV Power button and adjust the brightness, contrast, color, sharpness, and/or hue of the television.

When you press the TV Power button, the brightness level indicator will appear on the television screen. Press the Volume (VOL.) buttons to adjust the brightness setting if desired.

Next, press the Channel (CHAN) buttons until the contrast, color, sharpness, or hue level indicator appears. Adjust the settings, if desired, by pressing the Volume buttons.

### 3. Press the TV button again and add or delete channels.

Note: Complete this step only if you are using analog cable.

After all valid cable channels available in your area have been saved into the television's memory (see step 5 on this page), you can manually add channels or delete unwanted channels.

To add or delete a cable channel, first press the Channel buttons until the desired channel number appears on the screen. Then, press the Volume increase button to add the channel, or the Volume decrease button to delete the channel. Continue this process until you have added all desired channels and deleted all unwanted channels.

### 4. Press the TV Power button again and select a cable connection if necessary.

If you have connected a CATV cable, one of the three Cable settings should be selected; try all three Cable settings, if necessary, to find the optimal setting. Press the Volume increase button to select the Standard Cable setting, the Channel decrease button to select the Cable IRC setting, or the Channel increase button to select the Cable HRC setting.

### 5. Press the TV button again and save cable channels into the television's memory.

When you press the TV button, the television will begin scanning all of the cable channels available in your area. When no cable signal is detected on a channel, the channel will be skipped. When a cable signal is detected, the channel will be saved into memory and the next channel will be selected. This process will continue until the highest channel is reached. **Do not remove the key while the television is scanning channels.** Note: If you are viewing channels through an external source such as a cable box or a VCR, the television will save only the channel used by the external source.

### 6. When you are finished using the information mode, remove the key from the console.

To exit the information mode at any time (except while saving channels), remove the key from the console.

## HOW TO USE THE SOUND SYSTEM

To play music or audio books through the console's speaker, you must connect your MP3 player, CD player, or other personal audio player to the console. Locate the audio cable below the television on the console, and plug it into a jack on your MP3 player, CD player, or other personal audio player. **Make sure that the audio cable is fully plugged in.**

Next, select the MP4 source on the console by pressing the TV Power button repeatedly until "MP4" appears on the screen.

Then, press the Play button on your MP3 player, CD player, or other personal audio player. Adjust the volume on your personal audio player. You can also adjust the volume on the console by pressing the Volume (VOL) increase and decrease buttons.

If you are using a personal CD player or DVD player and the CD or DVD skips, set the CD player or DVD player on the floor or another flat surface instead of on the console.

## HOW TO ADJUST THE CUSHIONING SYSTEM

The treadmill features a cushioning system that reduces the impact as you walk or run on the treadmill. To increase the firmness of the walking platform, step off the treadmill and slide the platform cushions toward the front of the treadmill. To decrease the firmness, step off the treadmill and slide the platform cushions toward the back of the treadmill. **Note: Make sure that both cushions are set at the same firmness level. The faster you run on the treadmill, or the more you weigh, the firmer the walking platform should be.**

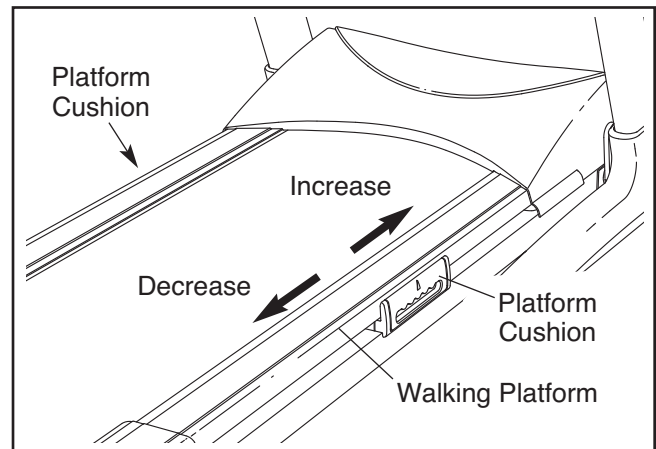

# HOW TO FOLD AND MOVE THE TREADMILL

## HOW TO FOLD THE TREADMILL FOR STORAGE

Before folding the treadmill, adjust the incline to the lowest position. If you do not do this, you may damage the treadmill when you fold it. Remove the key and unplug the power cord. **CAUTION:** You must be able to safely lift 45 lbs. (20 kg) to raise, lower, or move the treadmill.

1. Hold the metal frame firmly in the location shown by the arrow at the right. **CAUTION:** To decrease the possibility of injury, do not lift the frame by the plastic foot rails. To raise the frame, bend your legs, keep your back straight, and lift with your legs. Raise the frame about halfway to the vertical position.

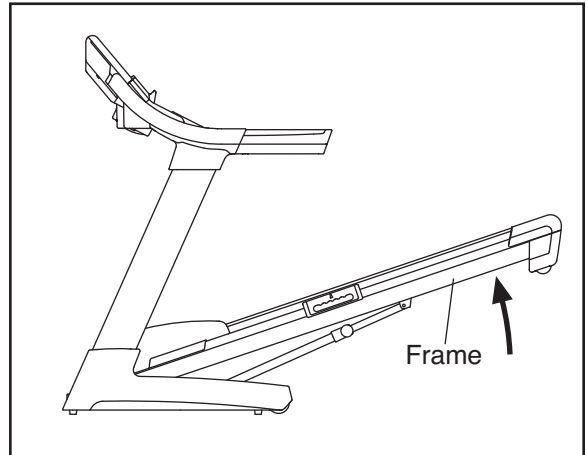

2. Raise the frame until the latch knob locks into the storage position. **Make sure that the latch knob is locked in the storage position.**

To protect the floor or carpet from damage, place a mat under the treadmill. Keep the treadmill out of direct sunlight. Do not leave the treadmill in the storage position in temperatures above 85° F (30° C).

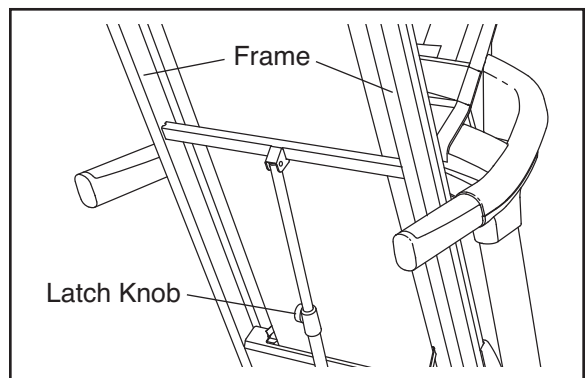

## HOW TO MOVE THE TREADMILL

Before moving the treadmill, convert the treadmill to the storage position as described above. **Make sure that the latch knob is locked in the storage position.**

1. Hold the handrails and place one foot against one of the wheels.
2. Tilt the treadmill back until it rolls freely on the wheels. Carefully move the treadmill to the desired location. **Never move the treadmill without tipping it back. To reduce the risk of injury, use extreme caution while moving the treadmill. Do not attempt to move the treadmill over an uneven surface.**
3. Place one foot against one of the wheels, and carefully lower the treadmill until it is resting in the storage position.

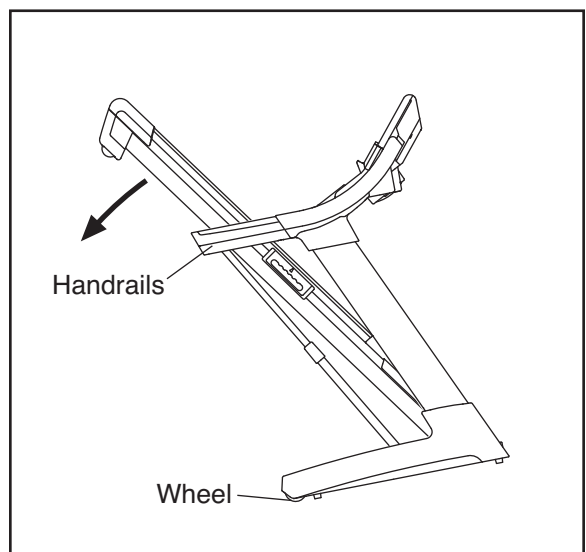

## HOW TO LOWER THE TREADMILL FOR USE

1. Hold the upper end of the treadmill with your right hand. Pull the latch knob to the left and hold it. Pivot the frame downward and release the latch knob. Note: To release the latch knob, it may be necessary to push the frame forward as you pull the latch knob to the left.
2. **Hold the metal frame firmly with both hands**, and lower it to the floor. **CAUTION:** To decrease the possibility of injury, do not lower the frame by gripping only the plastic foot rails. Do not drop the frame to the floor. Make sure to bend your legs and keep your back straight.

# TROUBLESHOOTING

Most treadmill problems can be solved by following the steps below. Find the symptom that applies, and follow the steps listed. If further assistance is needed, please see the front cover of this manual.

**PROBLEM: The power does not turn on**

**SOLUTION:** a. Make sure that the power cord is plugged into a surge suppressor, and that the surge suppressor is plugged into a properly grounded outlet (see page 12). Use only a single-outlet surge suppressor that meets all of the specifications described on page 12. **IMPORTANT: The treadmill is not compatible with GFCI-equipped outlets.**

b. After the power cord has been plugged in, make sure that the key is inserted into the console.

c. Check the reset/off circuit breaker located on the treadmill frame near the power cord. If the switch protrudes as shown, the circuit breaker has tripped. To reset the circuit breaker, wait for five minutes and then press the switch to the reset position.

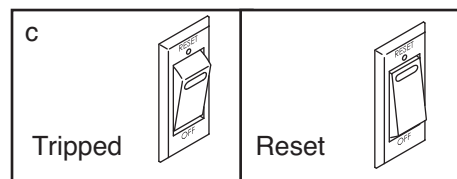

**PROBLEM: The power turns off during use**

**SOLUTION:** a. Check the reset/off circuit breaker (see the drawing above). If the circuit breaker has tripped, wait for five minutes and then press the switch to the reset position.

b. Make sure that the power cord is plugged in. If the power cord is plugged in, unplug it, wait for five minutes, and then plug it back in.

c. Remove the key from the console. Reinsert the key into the console.

d. If the treadmill still will not run, please see the front cover of this manual.

**PROBLEM: The displays of the console do not function properly**

**SOLUTION:** a. Remove the key from the console and **UNPLUG THE POWER CORD**. Place the treadmill in the storage position (see HOW TO FOLD AND MOVE THE TREADMILL on page 25).

Next, remove the two indicated 3/4" Screws (4).

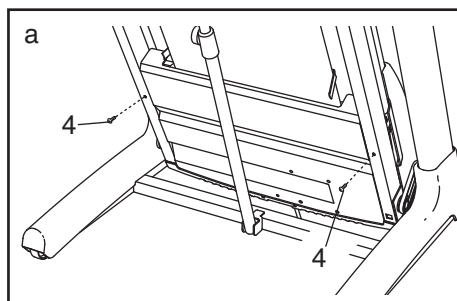

Lower the treadmill (see HOW TO LOWER THE TREADMILL FOR USE on page 25). Remove the four indicated 3/4" Screws (4), and remove the Hood (44).

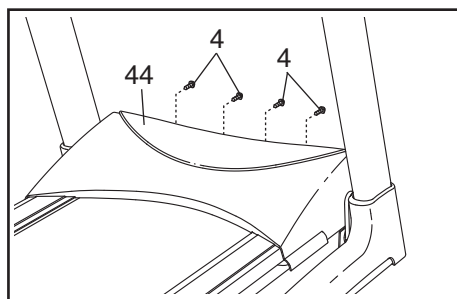

Next, locate the Reed Switch (20) and the Magnet (12) on the left side of the Pulley (11). Turn the Pulley until the Magnet is aligned with the Reed Switch.

**Make sure that the gap between the Magnet and the Reed Switch is about 1/8 in. (3 mm).** If necessary, loosen the indicated 3/4" Tek Screw (29), move the Reed Switch slightly, and then retighten the Tek Screw. Reattach the Hood (not shown) with the six 3/4" Screws (not shown). Run the treadmill for a few minutes to check for a correct speed reading.

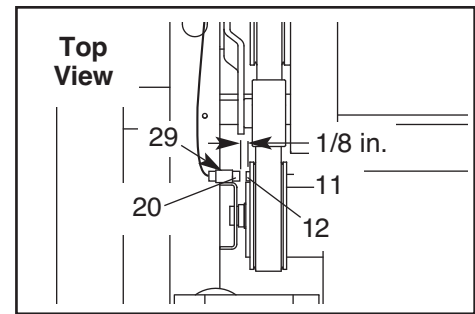

**PROBLEM: The walking belt slows when walked on**

**SOLUTION:** a. Use only a single-outlet surge suppressor that meets all of the specifications described on page 12.

b. If the walking belt is overtightened, treadmill performance may decrease and the walking belt may become damaged. Remove the key and **UNPLUG THE POWER CORD**. Using the hex key, turn both rear roller bolts counterclockwise, 1/4 of a turn. When the walking belt is properly tightened, you should be able to lift each edge of the walking belt 3 to 4 in. (8 to 10 cm) off the walking platform. Be careful to keep the walking belt centered. Then, plug in the power cord, insert the key, and run the treadmill for a few minutes. Repeat until the walking belt is properly tightened.

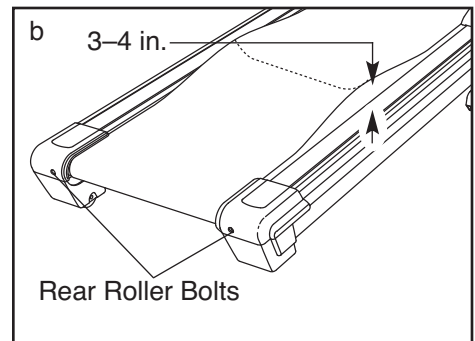

c. If the walking belt still slows when walked on, please see the front cover of this manual.

**PROBLEM: The walking belt is off-center or slips when walked on**

**SOLUTION:** a. If the walking belt is off-center, remove the key and **UNPLUG THE POWER CORD**. **If the walking belt has shifted to the left**, use the hex key to turn the left rear roller bolt clockwise 1/2 of a turn; **if the walking belt has shifted to the right**, turn the left rear roller bolt counterclockwise 1/2 of a turn. Be careful not to overtighten the walking belt. Plug in the power cord, insert the key, and run the treadmill for a few minutes. Repeat until the walking belt is centered.

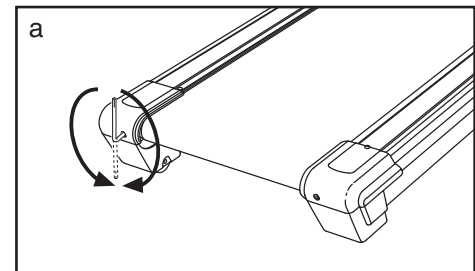

b. If the walking belt slips when walked on, first remove the key and **UNPLUG THE POWER CORD**. Using the hex key, turn both rear roller bolts clockwise, 1/4 of a turn. When the walking belt is correctly tightened, you should be able to lift each edge of the walking belt 3 to 4 in. (8 to 10 cm) off the walking platform. Be careful to keep the walking belt centered. Then, plug in the power cord, insert the key, and carefully walk on the treadmill for a few minutes. Repeat until the walking belt is properly tightened.

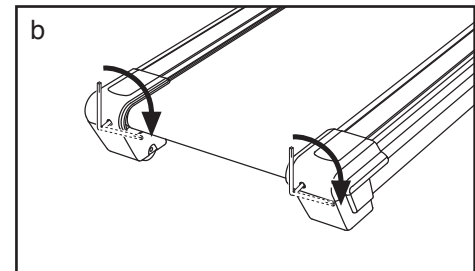

**PROBLEM: The incline of the treadmill does not change correctly**

**SOLUTION:** a. With the key in the console, press one of the Incline buttons. **While the incline is changing, remove the key.** After a few seconds, re-insert the key. The treadmill will automatically rise to the maximum incline level and then return to the minimum level. This will recalibrate the incline system.

**PROBLEM: The console displays remain lit when you remove the key from the console**

**SOLUTION:** a. The console features a display demo mode, designed to be used if the treadmill is displayed in a store. If the displays remain lit when you remove the key, the demo mode is turned on. To turn off the demo mode, hold down the Stop button for a few seconds. If the displays are still lit, see THE INFORMATION MODE on page 23 to turn off the demo mode.

**PROBLEM: Television reception is poor**

**SOLUTION:** a. Check for the problems listed below and follow the applicable instructions.

- Ignition (black spots or horizontal streaks that appear or a picture that flutters or drifts)—Usually this is caused by interference from automobile ignition systems, neon lamps, electric drifts, or other electric appliances. Try changing the position of other electric appliances to correct the problem. Make sure that the treadmill is plugged into its own electrical circuit.
- Ghosts—Ghosts are caused by the television signal following two paths—one is the direct path and the other is reflected from tall buildings, hills, or other objects.
- Blue Screen—If the cable channel signal is weak, the picture may be of poor quality or a blue screen may appear.

Note: If one of these symptoms appears, the symptom may be caused by the local cable company signal reception. Contact the local cable company.

**PROBLEM: The chest pulse sensor does not function properly**

**SOLUTION:** a. If the chest pulse sensor does not function properly, see CHEST PULSE SENSOR TROUBLESHOOTING on page 11.

# EXERCISE GUIDELINES

**⚠ WARNING:** Before beginning any exercise program, consult your physician. This is especially important for persons over age 35 or persons with pre-existing health problems.

The pulse sensor is not a medical device. Various factors may affect the accuracy of heart rate readings. The pulse sensor is intended only as an exercise aid in determining heart rate trends in general.

These guidelines will help you to plan your exercise program. For detailed exercise information, obtain a reputable book or consult your physician. Remember, proper nutrition and adequate rest are essential for successful results.

## EXERCISE INTENSITY

Whether your goal is to burn fat or to strengthen your cardiovascular system, exercising at the proper intensity is the key to achieving results. You can use your heart rate as a guide to find the proper intensity level. The chart below shows recommended heart rates for fat burning and aerobic exercise.

165	155	145	140	130	125	115	♥
145	138	130	125	118	110	103	♥
125	120	115	110	105	95	90	♥
<hr/>							
20	30	40	50	60	70	80	

To find the proper intensity level, find your age at the bottom of the chart (ages are rounded off to the nearest ten years). The three numbers listed above your age define your “training zone.” The lowest number is the heart rate for fat burning, the middle number is the heart rate for maximum fat burning, and the highest number is the heart rate for aerobic exercise.

**Burning Fat**—To burn fat effectively, you must exercise at a low intensity level for a sustained period of time. During the first few minutes of exercise, your body uses *carbohydrate calories* for energy. Only after the first few minutes of exercise does your body begin to use stored *fat calories* for energy. If your goal is to burn fat, adjust the intensity of your exercise until your heart rate is near the lowest number in your training zone. For maximum fat burning, exercise with your heart rate near the middle number in your training zone.

**Aerobic Exercise**—If your goal is to strengthen your cardiovascular system, you must perform aerobic exercise, which is activity that requires large amounts of oxygen for prolonged periods of time. For aerobic exercise, adjust the intensity of your exercise until your heart rate is near the highest number in your training zone.

## WORKOUT GUIDELINES

**Warming Up**—Start with 5 to 10 minutes of stretching and light exercise. A warm-up increases your body temperature, heart rate, and circulation in preparation for exercise.

**Training Zone Exercise**—Exercise for 20 to 30 minutes with your heart rate in your training zone. (During the first few weeks of your exercise program, do not keep your heart rate in your training zone for longer than 20 minutes.) Breathe regularly and deeply as you exercise—never hold your breath.

**Cooling Down**—Finish with 5 to 10 minutes of stretching. Stretching increases the flexibility of your muscles and helps to prevent post-exercise problems.

## EXERCISE FREQUENCY

To maintain or improve your condition, complete three workouts each week, with at least one day of rest between workouts. After a few months of regular exercise, you may complete up to five workouts each week, if desired. Remember, the key to success is to make exercise a regular and enjoyable part of your everyday life.

# PART LIST—Model No. NTL19007.4

R1008A

To locate the parts listed below, see the EXPLODED DRAWING attached in the center of this manual.

Key No.	Qty.	Description	Key No.	Qty.	Description
1	2	Foot Rail Cover	51	1	Right Rear Foot
2	2	Foot Rail	52	4	Rear Wheel
3	16	Cushion Screw	53	2	Rear Wheel Bolt
4	58	3/4" Screw	54	1	Right Rear Endcap
5	1	Book Rack	55	4	Bracket Washer
6	1	Walking Platform	56	2	Rear Roller Adjustment Bolt
7	2	Belt Guide	57	1	Hex Key
8	4	Belt Guide Screw	58	1	Left Rear Foot
9	2	Front Isolator	59	1	Left Rear Endcap
10	2	Platform Bolt, Front	60	1	Rear Roller
11	1	Front Roller/Pulley	61	2	Platform Nut
12	1	Magnet	62	2	Platform Bolt, Rear
13	17	1/2" Screw	63	1	Console Fan
14	1	Reed Switch Clip	64	6	Handrail Bolt
15	2	Incline Rod Bushing	65	1	Console Base
16	2	Lift Arm	66	1	Console
17	2	Lift Pivot Bolt	67	1	TV Console
18	2	Hood Mount	68	2	Motor Bushing
19	2	Lift Arm Spacer	69	7	Electronics Screw
20	1	Reed Switch	70	1	Pulse Receiver Cover
21	2	Cushion Track	71	1	Console Wire Harness
22	1	Power Cord Grommet	72	4	Upright Bolt
23	4	Console Clamp Screw	73	1	Left Upright
24	1	Lift Motor Bolt, Bottom	74	1	Right Upright
25	1	Ferrite Clamp	75	1	Upright Wire Harness
26	4	Base Pad Spacer	76	1	Left Base Cover
27	1	Reset/Off Circuit Breaker	77	1	Right Base Cover
28	1	Motor Belt	78	8	Console Screw
29	9	3/4" Tek Screw	79	1	Hood Cowling
30	2	Lift Pivot Bolt	80	4	Console Crossbar Star Washer
31	1	Drive Motor	81	4	Base Pad
32	2	Motor Bolt	82	4	1" Tek Screw
33	4	Electronic Bracket Nut	83	1	Base
34	1	Electronic Bracket	84	1	Motor Plate
35	1	Front Endcap	85	2	Wheel Bolt
36	1	Controller	86	2	Wheel
37	1	Incline Rod	87	3	Caution Decal
38	10	Nut	88	1	Power Cord
39	1	Lift Motor	89	1	Key/Clip
40	1	Lift Motor Bolt, Top	90	10	Upright Star Washer
41	1	AV Cover	91	4	Releasable Tie
42	2	Platform Cushion	92	2	Tie Clamp
43	1	Power Cord Bracket	93	8	Plastic Tie
44	1	Hood	94	2	Handrail Cover
45	4	Hood Clip	95	1	Left Upright Sleeve
46	2	Grommet	96	1	Right Upright Sleeve
47	1	Walking Belt	97	1	AV Wire
48	1	Frame	98	1	Ground Nut
49	1	TV Cable	99	1	Handrail
50	1	Chest Pulse Sensor	100	1	Latch Assembly

Key No.	Qty.	Description	Key No.	Qty.	Description
101	1	Latch Warning Decal	116	2	Console Clamp
102	1	AV Wire Nut	117	1	Upper Latch Bolt
103	1	iFit Card Kit	118	1	Latch Knob
104	1	Chest Pulse Strap	119	1	Latch Endcap
105	2	Rear Roller Washer	120	1	Left Grip
106	1	Incline/Controller Wire	121	1	Right Grip
107	1	Incline Stop Bracket	122	3	4" Ground Wire
108	1	Stop Bracket Spacer	123	1	Console TV Cable
109	1	Static Decal	124	1	Speaker Cover
110	1	Console Plate	125	1	Speaker
111	2	TV Cable Nut	126	4	Speaker Screw
112	1	TV Cable Star Washer	127	3	#8 x 1/2" Ground Screw
113	1	Lower Latch Bolt	*	–	4" White Wire, M/F
114	4	Handrail Cover Fastener	*	–	User's Manual
115	1	Audio/Video Wire Harness			

Note: Specifications are subject to change without notice. See the back cover of this manual for information about ordering replacement parts. \*These parts are not illustrated.

# EXPLODED DRAWING—Model No. NTL19007.4

R1008A

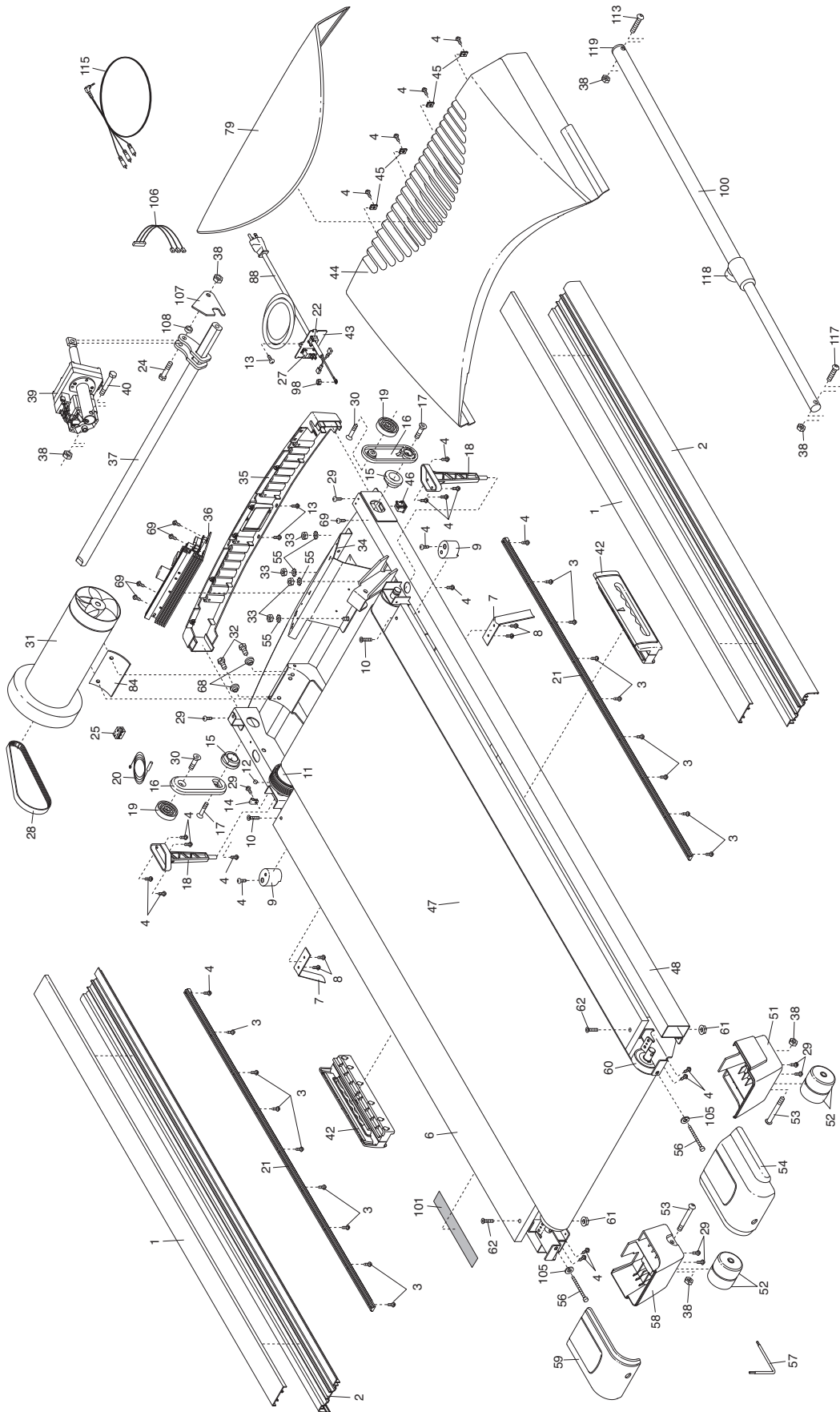

# EXPLODED DRAWING—Model No. NTL19007.4

R1008A

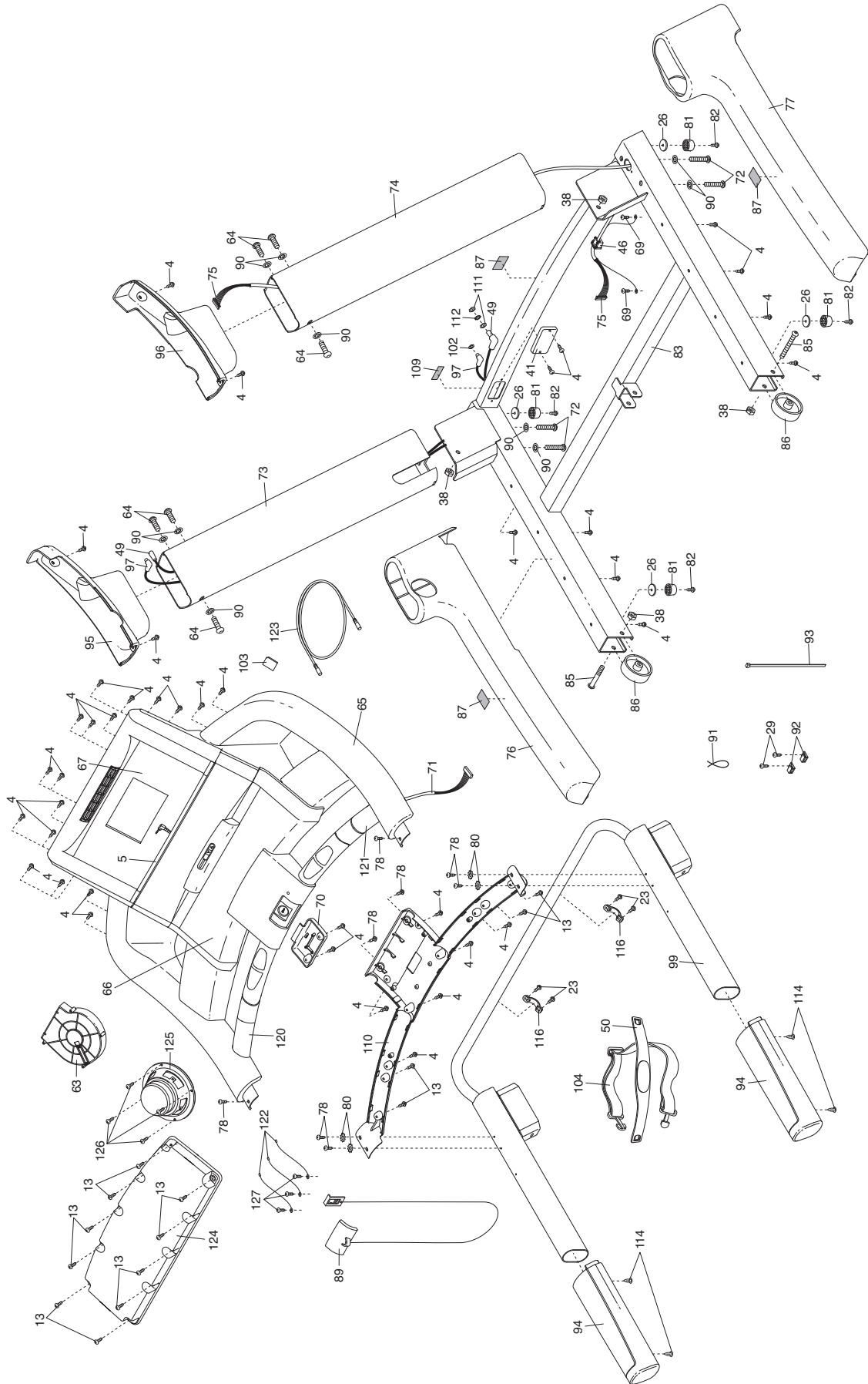

---

# ORDERING REPLACEMENT PARTS

To order replacement parts, please see the front cover of this manual. To help us assist you, be prepared to provide the following information when contacting us:

- the model number and serial number of the product (see the front cover of this manual)
- the name of the product (see the front cover of this manual)
- the key number and description of the replacement part(s) (see the PART LIST near the end of this manual and the EXPLODED DRAWING in the center of this manual)

## LIMITED WARRANTY

ICON Health & Fitness, Inc. (ICON) warrants this product to be free from defects in workmanship and material, under normal use and service conditions. The frame and drive motor are warranted for a lifetime. Parts are warranted for five (5) years from the date of purchase. Labor is warranted for one (1) year from the date of purchase.

This warranty extends only to the original purchaser. ICON's obligation under this warranty is limited to repairing or replacing, at ICON's option, the product through one of its authorized service centers. All repairs for which warranty claims are made must be preauthorized by ICON. If the product is shipped to a service center, freight charges to and from the service center will be the customer's responsibility. For replacement parts shipped while the product is under warranty, the customer will be responsible for a minimal handling charge. For in-home service, the customer will be responsible for a minimal trip charge. This warranty does not extend to any damage to a product caused by or attributable to freight damage, abuse, misuse, improper or abnormal usage, or repairs not provided by an ICON authorized service center; products used for commercial or rental purposes; or products used as store display models. No other warranty beyond that specifically set forth above is authorized by ICON.

ICON is not responsible or liable for indirect, special, or consequential damages arising out of or in connection with the use or performance of the product; damages with respect to any economic loss, loss of property, loss of revenues or profits, loss of enjoyment or use, or costs of removal or installation; or other consequential damages of whatsoever nature. Some states do not allow the exclusion or limitation of incidental or consequential damages. Accordingly, the above limitation may not apply to you.

The warranty extended hereunder is in lieu of any and all other warranties, and any implied warranties of merchantability or fitness for a particular purpose are limited in their scope and duration to the terms set forth herein. Some states do not allow limitations on how long an implied warranty lasts. Accordingly, the above limitation may not apply to you.

This warranty gives you specific legal rights. You may also have other rights that vary from state to state.

**ICON Health & Fitness, Inc., 1500 S. 1000 W., Logan, UT 84321-9813**