



**Standard Commercial Treadmill  
Owner's Manual**

**C932i**

**IMPORTANT SAFETY INSTRUCTIONS****IMPORTANT SAFETY INSTRUCTIONS**

When using an electrical appliance, basic precautions should always be taken, including the following:

- To ensure your safety and to protect the unit, read all the instructions before assembling and using the treadmill.
- To ensure the proper use and safety of the treadmill, make sure that all users read this manual. Please make this manual a part of your club's training program. Remind the club users that before beginning any fitness program, they should obtain complete physical examinations from their physicians.

*Il est conseillé de subir un examen médical complet avant d'entreprendre tout programme d'exercice. Si vous avez des étourdissements ou des faiblesses, arrêtez les exercices immédiatement.*

**DANGER** — To reduce the risk of electrical shock, always unplug the unit from its power source before cleaning or performing any maintenance tasks.

**WARNING** — To reduce the risk of burns, fire, electric shock, or injury to persons, take the following precautions:

- Do not allow children or those unfamiliar with its operation on or near the C932i treadmill. Do not leave children unsupervised around the treadmill.
- Never leave the treadmill unattended. Unplug the unit from the power outlet when it is not in use, before cleaning it, and before putting on or taking off parts. Do not adjust the running belt when someone is standing on the unit.
- Assemble and operate the treadmill on a solid, level surface. Locate the treadmill a few feet from walls or furniture. Check the unit before each use and verify that all fasteners are secure. Maintain the treadmill in good working condition.
- Use the treadmill only for its intended purpose as described in this manual. Do not use accessory attachments that are not recommended by the manufacturer—such attachments might cause injuries.
- If you purchased the optional chest strap, review the guidelines found in the literature that is supplied with that option.
- Never operate the unit if it is damaged, if it is not working properly, if it has been dropped, or dropped in water. Return the C932i to a service center for examination and repair.
- Keep all electrical components such as the motor, power cord, and I/O switch, away from liquids to prevent shock. Do not set anything on the handrail, display console, or hood. Place liquids, magazines and books in the appropriate receptacles.
- Keep the power cord and plug away from heated surfaces.
- Do not operate where aerosol (spray) products are being used or where oxygen is being administered.
- Do not use outdoors.
- The security clip must be attached at waist level prior to beginning a workout. A cord connects the security clip to the red STOP button on the console. If a user encounters difficulties, a strong tug on the security cord or a quick tap on the red STOP button will stop the running belt.
- Use care when getting on or off the treadmill. Use the stationary handrail whenever possible. Place your feet firmly on the right and left side platforms before the running belt begins moving (prior to a workout). Step onto the running belt when the speed is at or below 1 mph (1.6 kph).

## IMPORTANT SAFETY INSTRUCTIONS

- Never step off the treadmill while the running belt is moving. Keep your body and head facing forward. Never attempt to turn around on the treadmill.
- Never turn ON the treadmill when someone is standing on the machine.
- Never block the air openings on the hood while operating the treadmill. Keep the air openings clean and free of lint, hair, or anything that might impeded the free flow of air. Never drop or insert objects into any opening.
- Wear proper exercise clothing and shoes during a workout—no loose clothing. Tie long hair back. Keep all loose towels away from the running surface. The running belt will not stop immediately if an object becomes caught in the belt or rollers.
- Do not rock the unit. Do not stand on the display console or hood.
- Do not overexert yourself or work to exhaustion. If you feel any pain or abnormal symptoms, stop your workout immediately and consult your physician.

### SAFETY APPROVAL

When identified with the ETL-c logo, the treadmill has been tested and conforms to the requirements of CAN/CSA-E-335-1/3-94, Safety of Household and Similar Electrical Appliances.

### GROUNDING INSTRUCTIONS

The C932i Low Impact Treadmill must be grounded. If it should malfunction or break down, grounding provides a path of least resistance for electric current which reduces the risk of electrical shock. The treadmill is equipped with a power cord having an equipment-grounding conductor and a grounding plug. The plug must be inserted into an appropriate outlet that is properly installed and grounded in accordance with all local codes and ordinances. If you do not follow these *Grounding Instructions*, you could void the Precor limited warranty.

**DANGER** — Improper connection of the equipment-grounding conductor can result in a risk of electric shock. Check with a qualified electrician or service person if you are in doubt as to whether the treadmill is properly grounded. Do not modify the plug provided with the treadmill—if it doesn't fit the outlet, get a proper outlet installed by a qualified technician.

**Diagram 1**  
Correct power plug for U.S. Markets:  
120-volt and 240-volt.

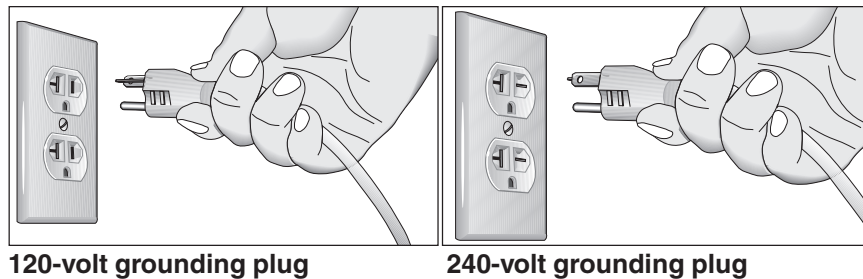

120-volt grounding plug

240-volt grounding plug

### 120V Units and 240V Units Designated for U.S. Markets

The C932i treadmill must be connected to a dedicated, grounded circuit. **A 20 amp dedicated circuit is recommended.** The treadmill is factory-equipped with a specific power supply cord to permit connection to a proper electric circuit as shown in Diagram 1. The power outlet must have the same configuration as the plug. No adapter should be used with this product.

**SAVE THESE INSTRUCTIONS**

**IMPORTANT SAFETY INSTRUCTIONS**

# Table of Contents

- Important Safety Instructions ..... 2**
  - Safety Approval ..... 3
  - Grounding Instructions ..... 3
  - Radio Frequency Interference (RFI) ..... 6
  - European Applications ..... 6
  - Obtaining Service ..... 7
  - About this Manual ..... 7
  
- Unpacking the Treadmill ..... 9**
  - Standard Equipment ..... 9
  - Other Equipment ..... 9
  - Hardware Kit ..... 10
  - Acquire Additional Tools ..... 10
  
- Setting Up the Treadmill ..... 11**
  - Installation Requirements ..... 11
  - Assembly Instructions ..... 11
  - Turning the Unit ON and OFF ..... 19
  - Checking the Alignment of the Running Belt ..... 20
  
- Club Information ..... 21**
  - Programming Tips ..... 22
  - Selecting the Language ..... 23
  - Determining the Units of Measure ..... 23
  - Determining the Club Speed Limit ..... 24
  - Setting a Workout Time Limit ..... 24
  - Setting a Pause Time Limit ..... 24
  - Setting a Cool Down Time Limit ..... 25
  - Viewing the Odometer, Hours of Use,  
Software Version, Error Log, and Serial Number ..... 25
  
- The C932i Display ..... 27**
  - Features on the Display Console ..... 27
  - Setup Mode and Prompts ..... 28
  - The Setup Mode and the QUICKSTART™ Feature ..... 29
  - Center Display During a Workout ..... 30

# Table of Contents

- The C932i Keypad ..... 31**
  - Keypad Tips ..... 31
  - Special Keypad Functions at the Precor Banner ..... 31
  - Keys on the Keypad ..... 33
  - Changing the Display Features Using the SELECT Key ..... 35
  
- Exercising on the C932i ..... 36**
  - Safety Features ..... 36
  - Using the Security Clip ..... 36
  - Using the Handrails ..... 36
  - Using the Red STOP Button ..... 37
  - Reviewing Keypad and Workout Tips ..... 37
  - Quick Steps to Working Out ..... 38
  - Cooling Down After a Workout ..... 39
  - Pause, Workout Summary, and Exit Features ..... 40
  
- C932i Programs ..... 42**
  - Program Features ..... 42
  - Program Descriptions ..... 43
  
- Heart Rate Capabilities ..... 45**
  - Using the SmartRate® Feature ..... 45
  - Heart Rate Control Program ..... 47
  
- Maintenance ..... 48**
  - Inspection ..... 48
  - Cleaning the Equipment ..... 48
  - Aligning the Running Belt ..... 48
  - Servicing the Treadmill ..... 50
  - Storing the Chest Strap ..... 50
  - Long Term Storage ..... 50
  - Warranty Registration ..... 53
  - Warranty ..... 55
  - Specifications ..... back cover

## **RADIO FREQUENCY INTERFERENCE (RFI)**

### **Federal Communications Commission Part 15**

The treadmill has been tested and found to comply with:

- The IEC EMC Directive (international electromagnetic compatibility certification)
- The limits for a Class A digital device, pursuant to Part 15 of the FCC Rules. These limits are designed to provide reasonable protection against harmful interference in a commercial installation. The treadmill generates, uses, and can radiate radio frequency energy and, if not installed and used in accordance with the owner's manual instructions, may cause harmful interference to radio communications. Operation of the treadmill in a residential area is likely to cause harmful interference. If this occurs, the user will be required to correct the interference at his or her own expense.

**CAUTION** — **Per the requirements of the Federal Communications Commission, changes or modifications to this product, not expressly approved by Precor, could void the user's authority to operate the product.**

### **Canadian Department of Communications**

This digital apparatus does not exceed the Class A limits for radio noise emissions from digital apparatus set out in the Radio Interference Regulations of the Canadian Department of Communications.

Le présent appareil numérique n'émet pas de bruits radioélectriques dépassant les limites applicables aux appareils numériques de la Class A prescrites dans le Règlement sur le brouillage radioélectrique édicté par le ministère des Communications du Canada.

## **EUROPEAN APPLICATIONS**

This product conforms to the requirements of the European Council Directive 89/336/EEC, *Electromagnetic Compatibility* and has been tested to the following standards:

**EN55022**, Limits & Methods of Measurement of Radio Interference, Information Technology Equipment (Class A). Per the standard, the treadmill is a Class A product. In a domestic environment, this product may cause radio interference, in which case the user is responsible to take adequate measures to alleviate the interference.

**EN50082-1**, Generic Immunity Standard for Residential, Commercial and Light Industrial Products (Class A).

This product additionally conforms to the requirements of the European Council Directive 73/23/EEC, *Low Voltage Directive* and has been tested to the following standard:

**IEC 335-1**, Safety of Household and similar Electrical Appliances.

## OBTAINING SERVICE

Do not attempt to service the treadmill yourself except for the maintenance tasks described in this manual. The treadmill does not contain any user-serviceable parts. For information about product operation or service, visit the Precor Web Site at [www.precor.com](http://www.precor.com) or contact an authorized Precor Commercial Products Customer Support Representative at 1-888-665-4404.

To help customer support personnel expedite your call, have your serial number available. The serial number can be found on the shipping container or on the label near the power receptacle. If you have any questions regarding the treadmill, use the model and serial numbers whenever you call a Precor dealer or Commercial Products Customer Support Representative.

Model number: **C932i**

Unit number: \_\_\_\_\_ Serial number: \_\_\_\_\_

Unit number: \_\_\_\_\_ Serial number: \_\_\_\_\_

Unit number: \_\_\_\_\_ Serial number: \_\_\_\_\_

## ABOUT THIS MANUAL

This manual includes instructions for installing and using the treadmill. To maximize the use of the treadmill, please study this manual thoroughly. The manual uses the following conventions for identifying special information:

**Note:** Contains additional information.

**Important:** *Indicates information to which you should pay special attention.*

**CAUTION:** Indicates steps or information necessary to prevent harm to yourself or damage to the equipment.

**WARNING** — Provides instructions to prevent electrical damage to the equipment and injuries to yourself.

**DANGER** — Indicates steps you must take to prevent electrical shock.

**C O M M E R C I A L P R O D U C T S D I V I S I O N**

*Notes:*

## Unpacking the Treadmill

Thank you for purchasing the Precor C932i treadmill. Built to the exacting standards of the health club environment, the treadmill is intended for commercial use and can withstand the rigors of daily club use with little maintenance.

**Important:** Before using the treadmill, we urge you to familiarize yourself and your staff with the entire Owner's Manual. Understanding this manual will help you and your customers use the treadmill safely and successfully.

Your treadmill is carefully inspected before shipment so it should arrive in good operating condition. Precor ships the unit in the following pieces:

- Running bed assembly
- Right and left upright supports
- Display console
- Right and left center handrails (two sections) – found inside the cardboard packing material
- Right and left center handrail side covers – packaged inside a plastic bag
- Power cord – packaged inside a plastic bag in the shipping container
- Hardware kit – shrink wrapped to cardboard
- Owner's Manual – packaged inside a plastic bag in the shipping container

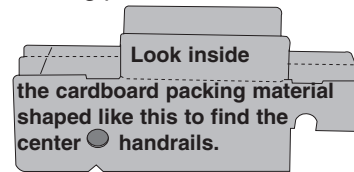

**CAUTION: This unit weighs over 280 pounds (126 kilograms). To prevent injury to yourself or damage to the equipment, obtain appropriate assistance before removing the unit from the pallet.**

If any items are missing, refer to *Obtaining Service* on page 7.

### STANDARD EQUIPMENT

The treadmill incorporates the Precor SmartRate® and Heart Rate features into its display console.

**Note:** An optional chest strap must be worn to transmit a user's heart rate to the display console.

### OTHER EQUIPMENT

Optional equipment available through your dealer includes:

- Cheststrap
- Side handrails

If you are interested in obtaining Precor option kits for your unit, check with your dealer. For customer support, see *Obtaining Service* on page 7.

Diagram 2 Hardware kit.

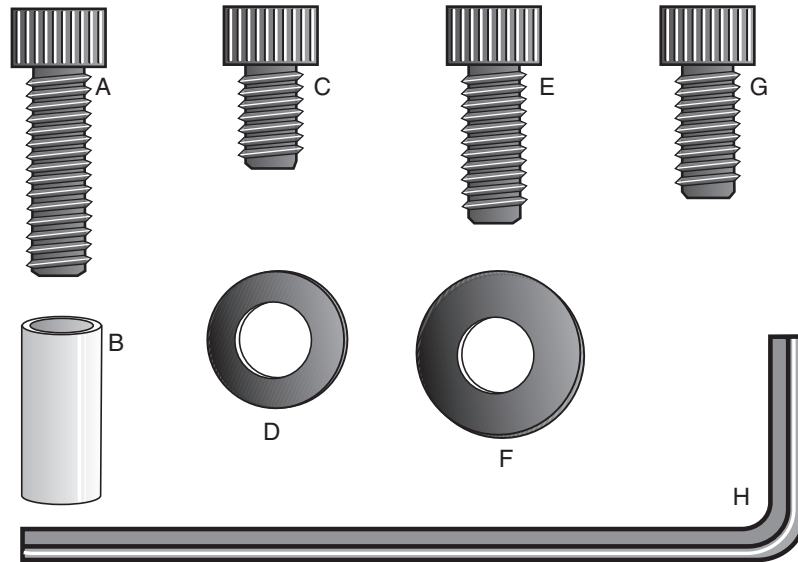

Carefully unpack the pieces of the treadmill and lay them on the floor near the location where you plan to use the treadmill.

## HARDWARE KIT

After unpacking the treadmill, open the hardware kit (refer to Diagram 2) and make sure that you have the following items:

- (A) four 2-inch long socket head screws — mount upright supports to base
- (B) four barrel spacers — place on 2-inch screws
- (C) ten  $\frac{3}{4}$ -inch long socket head screws
- (D) sixteen flat washers
- (E) two  $1\frac{1}{4}$ -inch socket head screws — handrail clamp assembly
- (F) four large diameter washers — place on handrail end cap screws
- (G) four 1-inch socket head screws — handrail mounting bracket
- (H)  $\frac{1}{4}$ -inch hex key — 3 inches by 10 inches

If any items are missing, refer to *Obtaining Service* on page 7.

**Note:** After assembling the treadmill, you will have four  $\frac{3}{4}$ -inch long socket head screws (C) and four flat washers (D) remaining. You can discard them if you wish. Also, be sure to store the hex key in a secure place. It is used for specific maintenance procedures that are described in this manual.

## ACQUIRE ADDITIONAL TOOLS

Obtain the following tools *before* assembling the treadmill.

- Wire cutter
- $\frac{1}{2}$ -inch box end wrench (or crescent wrench)
- Bubble level
- Medium weight string

## Setting Up the Treadmill

You do not need any special knowledge or experience to set up the treadmill. However, you will need assistance during assembly.

### INSTALLATION REQUIREMENTS

Follow these installation requirements when installing the treadmill. *If you do not install the treadmill according to the following guidelines, you could void the Precor limited warranty.*

- **Set up the treadmill on a solid, flat surface.** Unpack and assemble the treadmill close to where you plan to use it. Make sure that the surface under the unit is smooth and level. A level unit is required for the user's safety and proper operation.
- **Provide ample space around the unit.** Open space around the unit makes for a safer mount and dismount.
- **Fill out and mail the limited warranty card.** The serial number can be found on the shipping container or on the label near the power receptacle. Write the serial number onto the Precor limited warranty card found inside the back cover of this manual and in the *Obtaining Service* section on page 7.
- **Use the appropriate voltage, dedicated circuit, and grounding as specified on the treadmill. A 20 amp dedicated circuit is recommended.**

### ASSEMBLY INSTRUCTIONS

To assemble the treadmill, take the following steps.

1. **Obtain adult assistance.** Have your assistants help place the shipping carton close to the location where you plan to use the treadmill. Break down the side walls of the shipping carton so that they lie flat. Remove the loose contents.
2. **Make sure that the power switch is OFF.** Check the ON/OFF power switch on the front of the treadmill. Place the switch in the O (OFF) position. Make sure that the treadmill is **not** plugged into a power source.

**Diagram 3** *Lift the rear of the unit and roll it to its assembly location.*

End cap

*Lift rear by placing hands on opposite sides of the cross brace that is found under the rear cover.*

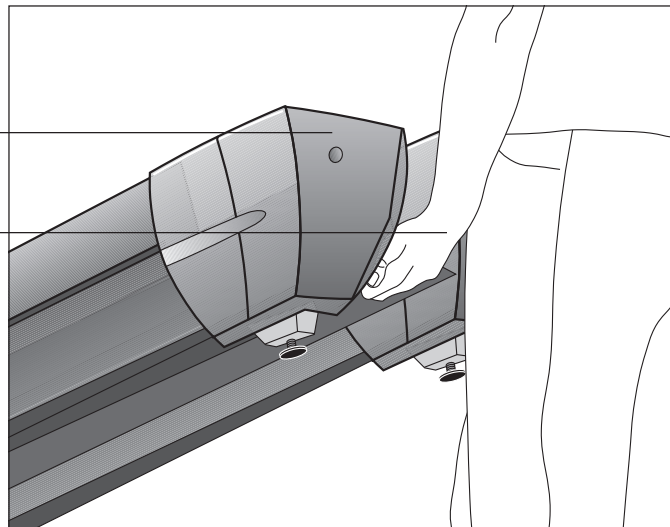

**CAUTION:** Do not lift the rear end of the treadmill by grasping the rear roller or the end cap. The running belt can move and the end caps can break off which may cause injury to you or to the unit.

3. **Move the treadmill.** Diagram 3. To avoid injury to yourself or damage to the unit, ask for help in placing the treadmill where you plan to use it. Diagram 3 illustrates how to properly lift the rear end so that you can roll it on its front wheels.

**Diagram 4** *Remove the shipping fasteners from the front panel.*

*Loosen the fasteners with a hex key while holding the nut with a crescent or box end wrench.*

The shipping fasteners are found on the right and left sides of the front panel.

Front panel

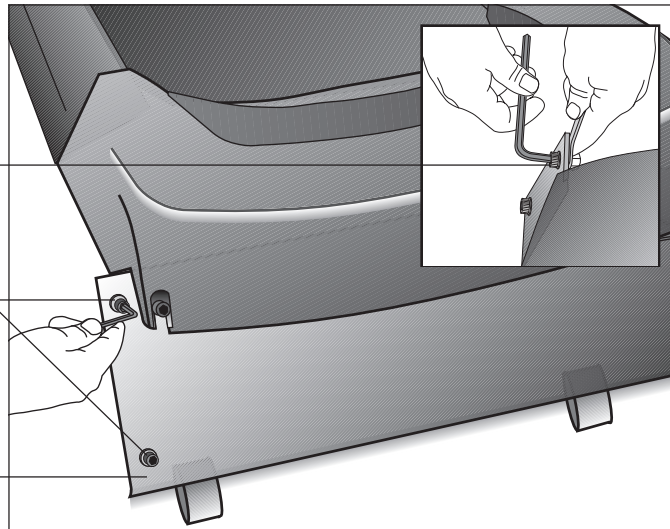

4. **Remove the shipping fasteners from the front panel.** Diagram 4. With the supplied hex key and a 1/2-inch box end wrench, loosen and remove the 4 bolts, washers and nuts on the front panel. These fasteners are used during shipping to hold the front plate in place. Discard the fasteners.
5. **Remove any tape or wire ties securing the display cable to the side of the unit.**

**Diagram 5** *Route the cable.*

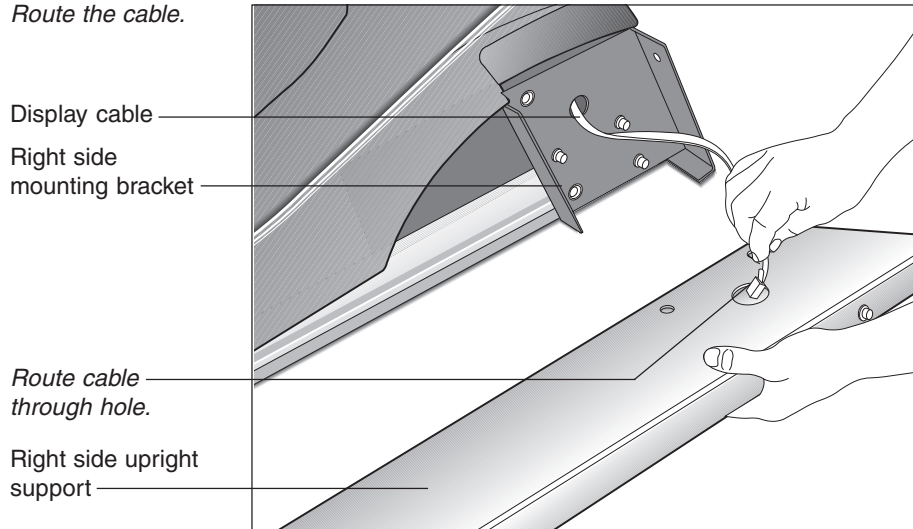

**CAUTION:** To avoid damage to the display cable, read and follow these steps carefully. Damage to the cable due to improper assembly is not covered by the Precor limited warranty.

6. **Route the display cable.** Diagram 5. Unwrap the cable and remove any kinks. Have an assistant hold the right upright support close to the base while you route the cable through it.

**Note:** Attaching a string to the cable with a washer tied to the opposite end of the string may help you route the cable through the upright support.

**Diagram 6** *Attach the upright supports.*

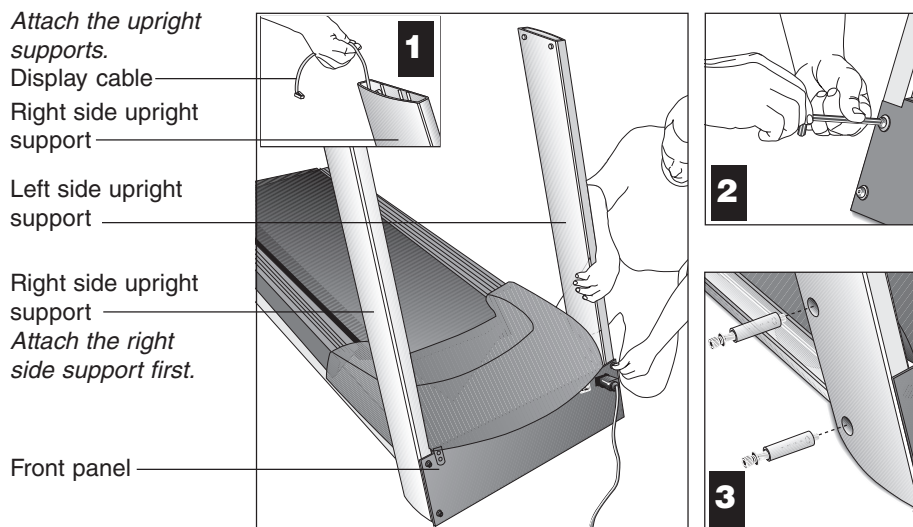

7. **Attach the *right side* upright support to the base assembly.** Diagram 6. Align the right side upright support with the base assembly mounting locations while your assistant keeps tension on the cable. Refer to Diagram 6, #1. To secure the upright support to the base assembly, take the following steps:

- a. Place a washer (D) onto each of two 3/4-inch screws (C). Thread the screws through the front panel and into the upright support. See Diagram 6, #2. Do not fully tighten the screws. Leave room for final adjustments.

**CAUTION: Avoid pinching the cable with the bolts and spacers.**

- b. Place a washer (D) and barrel spacer (B) on each of two 2-inch screws (A). Insert the screws through the upright support and thread them into the base mounts. See Diagram 6, #3. Do not securely tighten the screws until after the unit has been fully assembled.

8. **Attach the *left side* upright support to the base assembly.** Diagram 6. Align the upright support with the base assembly mounting bracket and secure it by following steps 7a. and 7b.

**Diagram 7** *Install the display console.*

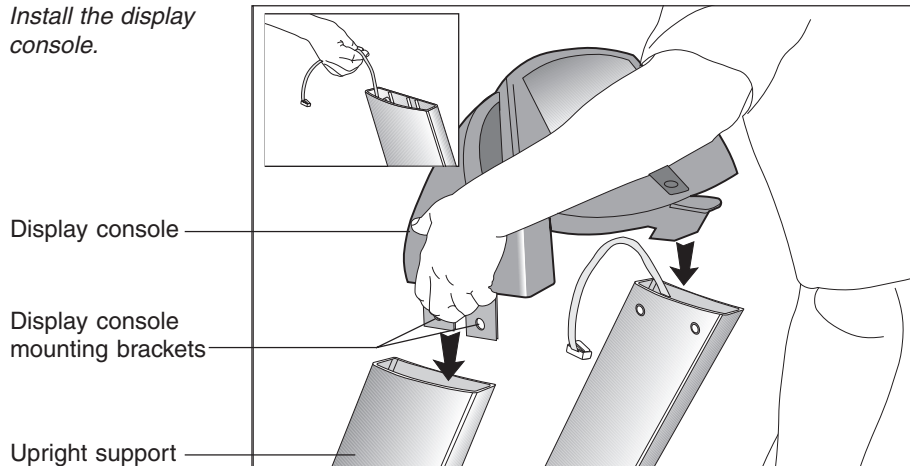

9. **Position the display console onto the upright supports.** Diagram 7. Make sure that the cable is routed through the top of the upright support. Have an assistant hold onto the cable (see inset) and then, rest the display console on the upright supports and align the mounting holes.

**CAUTION: Do not crimp or pinch the cable! Crimped or pinched cables are not covered by the Precor limited warranty.**

**Diagram 8** *Connect the cable.*

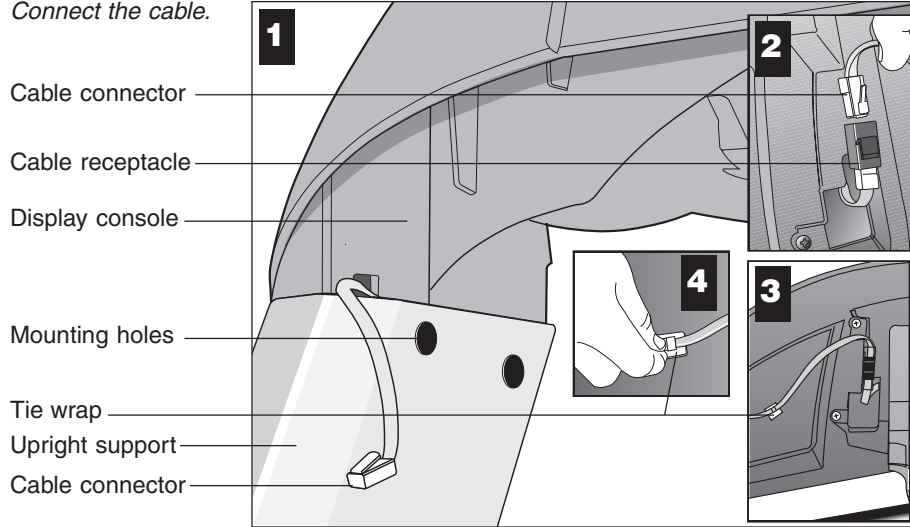

10. **Connect the display cable and secure the display console.** Refer to Diagram 8, #1 and take the following steps to secure the display cable and console.

- a. Attach the cable connector by sliding it into its receptacle underneath the console. A definite “click” is heard when the cable is properly attached. Refer to Diagram 8, #2. If you do not hear and feel the connector “snap” into place, reinsert it.
- b. So that the cable does not hang below the console, slide it into the two tie wrap clips found underneath the console. Refer to Diagram 8, #3 and #4.

**Diagram 9** *Install the center handrail.*

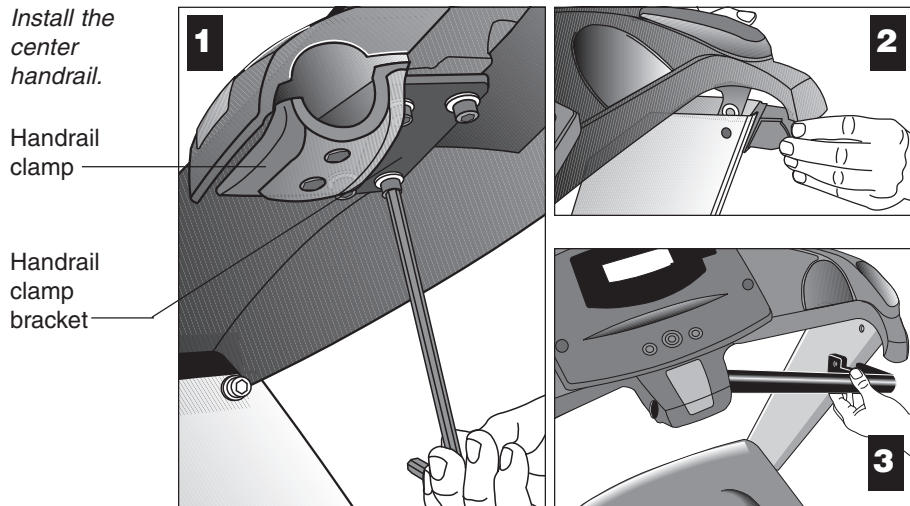

11. **Install the center handrail.** Loosen the four fasteners in the handrail clamp bracket with the hex key provided. See Diagram 9, #1. The center handrail is packaged in two pieces. Install one side at a time by following these steps:
  - a. Insert a handrail end cap. See Diagram 9, #2.
  - b. Slide the end of the handrail into the center clamp and rotate the handrail so that it falls inside the end cap. See Diagram 9, #3.

**Diagram 10** *Secure the display console and center handrail.*

Center handrail mounting bracket (right side)

1-inch screws (G) with washers (D) (right side)

Handrail end cap screw (C) with washer (F) (left side)

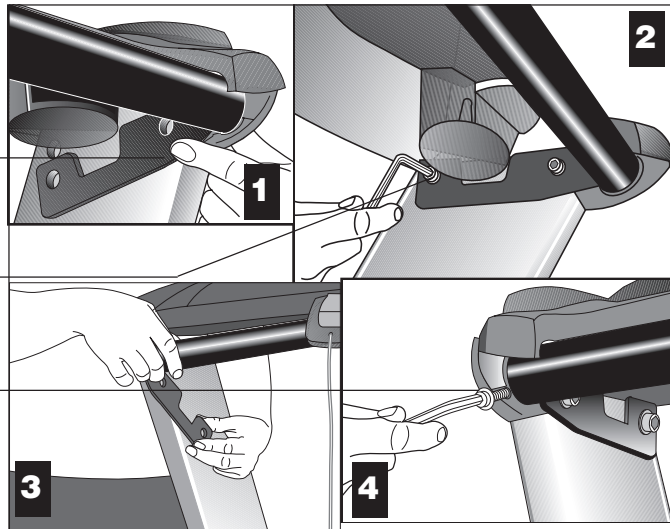

- c. Align the center handrail's mounting bracket with the holes in the upright support. See Diagram 10, #1. Insert two 1-inch screws (G) with washers (D) and finger tighten. See Diagram 10, #2. Do not securely tighten the screws until both sides of the center handrail have been attached. See Diagram 10, #1 and #2.
- d. Align the mounting holes in the handrail with the end cap. Place a washer (F) on screw (C) and insert the screw. Finger tighten. See Diagram 10, #4.
- e. Follow steps 9a. through 9d. on the opposite side.

**Diagram 11** *Secure the upper handrail clamp.*

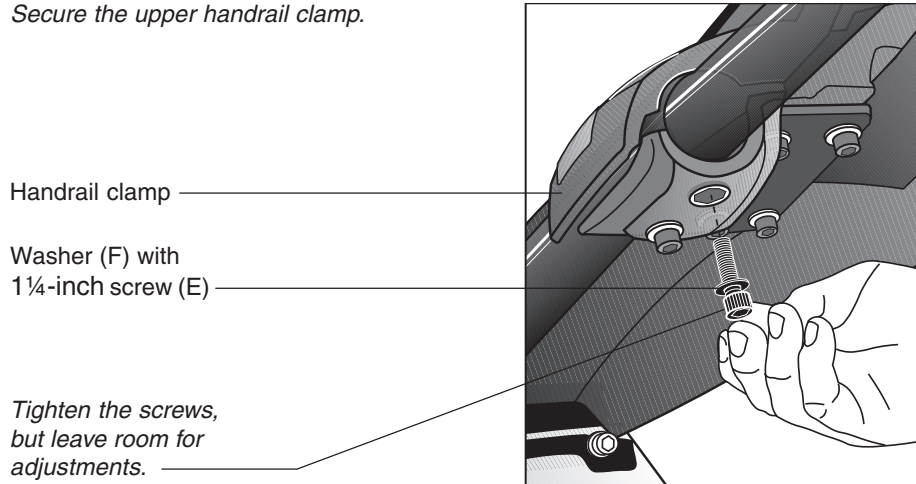

12. **Install fasteners in the handrail clamp.** Diagram 11. Return to the center handrail clamp and place a large washer (F) onto each of two screws (E). Thread the screws through the handrail clamp. Finger tighten.

**CAUTION:** Do not overtighten the screws or you may inadvertently cause stress cracks.

**Diagram 12** *Secure the fasteners.*

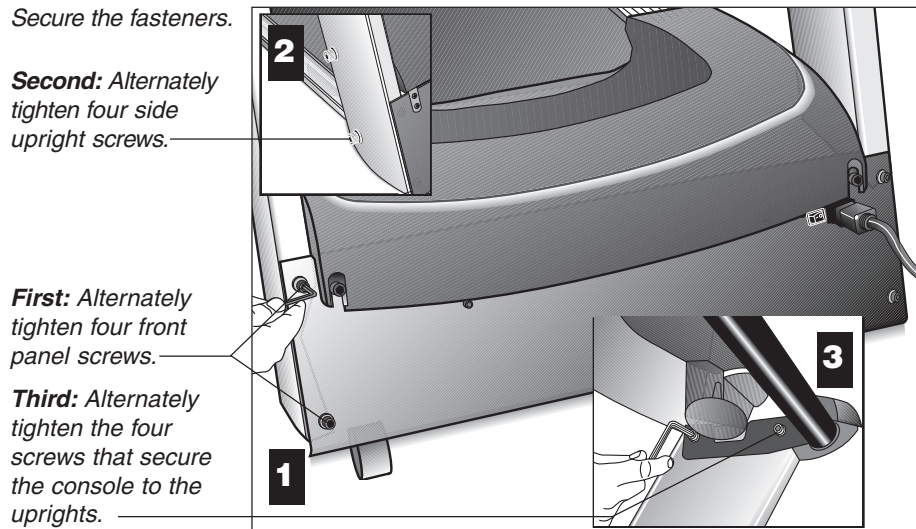

13. **Tighten all mounting screws with the hex key (H) provided.** Diagram 12. Start at the front of the treadmill with the four screws that attach the upright supports to the front panel. Tightening these screws first helps pull the rest of the treadmill's parts into alignment. Then, proceed with tightening the four screws (A) that secure the upright supports and the four display console assembly screws (C).

**Important:** For proper alignment, it is critical that the fasteners are tightened in the order shown in Diagrams 12 and 13.

**Diagram 13** Tighten the handrail fasteners.

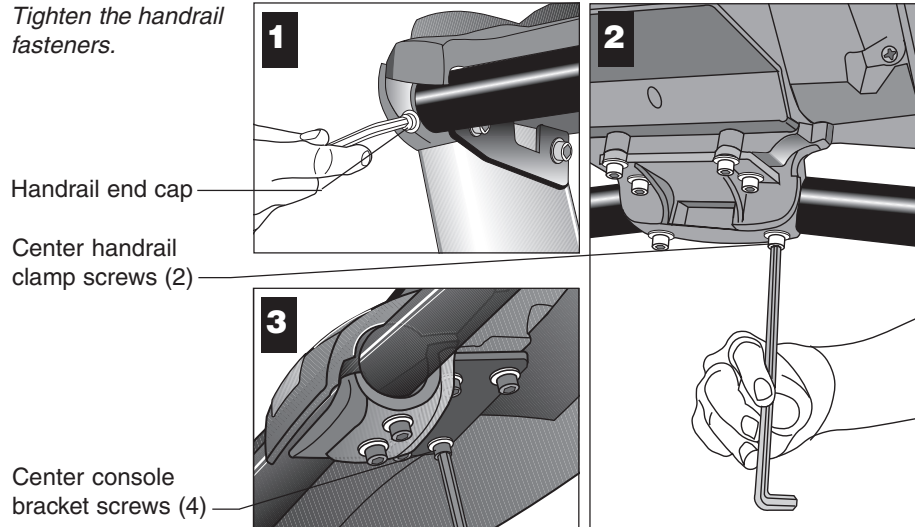

14. **Tighten all the center handrail fasteners.** Diagram 13. Start with tightening the two end cap screws and work inward. See Diagram 13, #1. So that you don't overtighten the fasteners, hold the supplied hex key by its 3-inch section and tighten the two center clamp screws. Refer to Diagram 13, #2. Next, tighten the four console bracket screws. Refer to Diagram 13, #3.

**Diagram 14**  
Level the unit.

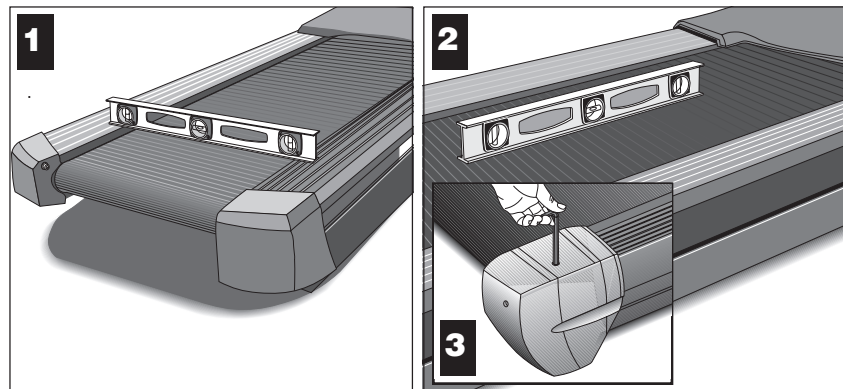

15. **Level the unit.** Diagram 14. The C932i has adjustable rear feet. Check to make sure that the running surface is level (use a bubble level as shown in Diagram 14). If the treadmill is placed on a slightly, uneven surface, adjusting the rear feet can help, but will not compensate for extremely uneven surfaces.

**Important:** If you need to make adjustments, adjust one rear foot at a time. **Do not** use the rear foot to raise or lower the unit more than 3/4-inches. Check the level of the unit after each adjustment.

16. **Adjust the rear deck.** Diagram 14, #3. To raise the rear deck, insert the 1/4-inch hex key (G). Make sure that the key is fully engaged and turn it clockwise. Turning the hex key counterclockwise lowers the unit.

**Diagram 15** *Connect to power outlet.*

On/Off switch

Power plug

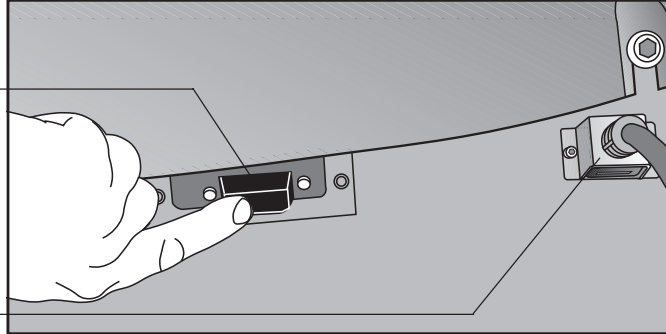

17. **Plug the power cord into an appropriate power outlet.** Refer to *Grounding Instructions* on page 3. Make sure that the ON/OFF (I/O) power switch, located on the front panel of the treadmill, is placed in the OFF (O) position before connecting to a power source.

**CAUTION: The treadmill requires a dedicated, grounded circuit. A 20 amp circuit is recommended. Make sure that no other product or machine uses the same circuit as the treadmill.**

**Important:** Always make inspecting the power cord connection part of your routine treadmill maintenance.

## **TURNING THE UNIT ON AND OFF**

Use the ON/OFF (I/O) power switch to turn the unit ON and OFF. This switch is located on the front of the unit, near the power plug receptacle.

To complete the installation of the treadmill, continue to *Checking the Alignment of the Running Belt* on the next page.

## CHECKING THE ALIGNMENT OF THE RUNNING BELT

The belt is aligned at the factory before shipment. However, during shipment or by using the treadmill on an uneven surface, the belt might move off center. Proper belt alignment is important because it allows the belt to remain centered and assures smooth operation.

Follow these steps to check the alignment:

**CAUTION: Do not walk on the running belt during this procedure.**

1. The treadmill has adjustable rear feet. Check to make sure that the running surface is level (refer to steps 15 and 16 on the previous pages). If the treadmill is placed on a slightly uneven surface, adjusting the rear feet can help, but will not compensate for extremely uneven surfaces.
2. Locate the I/O switch at the front of the treadmill and turn the unit ON.
3. Stand beside the treadmill and press QUICKSTART. The running belt starts automatically after the message, "**Belt Starting 3, 2, 1,...**" appears.

**CAUTION: If you hear any chafing or the running belt appears to be getting damaged, stop the running belt immediately by pressing the STOP key. Contact Customer Support.**

4. Continue standing next to the treadmill and hold down the SPEED ▲ key until the display shows a speed of 3 miles per hour (5 kph).
5. Walk around to the rear of the unit and observe the belt for a few minutes as it moves.

If the running belt,...	Then,...
tracks centered on the running surface (evenly distributed between the side rails)	the belt is functioning correctly and no adjustment is necessary.
runs or drifts off center	you need to adjust the belt; see <i>Aligning the Running Belt</i> , page 48.

**Important:** *If you notice that the belt needs alignment, make the adjustments at once. Failure to do so might cause the belt to tear or fray, which is not covered by the Precor, limited warranty.*

6. To stop the running belt, press the red STOP button.

If the belt is functioning correctly, the C932i treadmill is ready to use.

## Club Information

These next few pages provide information that lets you customize the treadmill for your Club. It is not information that your customer needs or, necessarily, should see. Information that you can access and features that can be customized are as follows:

<u>Custom Feature</u>	<u>Factory Setting</u>	<u>What you are allowed to change</u>
<b>Language</b>	English	Choose one of six languages: English, German, Spanish, French, Dutch, or Portuguese.
<b>Units of Measure</b>	U.S. Standard	Select between U.S. Standard and Metric displays.
<b>Maximum Speed</b>	0.5 to 11.0 mph	Determine the maximum speed that a user can select. Selections range between 0.5 to 11 mph (1 to 18 kph).
<b>Maximum Workout Time</b>	60 minutes	Set a maximum limit on workout time.  <b>Note:</b> Remember that the user can get up to an additional five-minute cool down period appended to a completed program. So, adjust the maximum time limit accordingly.
<b>Maximum Pause Time</b>	120 seconds	Set the maximum duration in which a user can "pause" his or her workout.
<b>Max. Cool Down Time</b>	5 minutes	Set the maximum duration in which a person can cool down after a workout.
<b>Odometer, Hours of Use</b>	Zero	Display only (no changes allowed).
<b>Software Version</b>	Current version	Displays the upper and lower software version number which is valuable when calling Customer Support.
<b>Error Log</b>	NO ERRORS	The treadmill stores the cumulative miles or kilometers, the number of hours that the unit has been in use, the software version and software type (which is valuable when calling Customer Support), and an error log (useful when troubleshooting).

**Note:** If your customers are interested in the learning more about the C932i treadmill, you may wish to direct them to the manual available on the web site ([www.precor.com](http://www.precor.com)). (The manual, which appears on the web site, does not contain the information found in this section.)

**Diagram 16**  
C932i display and keypad.

Center display  
**PRECOR**  
scrolling banner  
appears here.

**SELECT** key

**RESET** key

Keypad keys

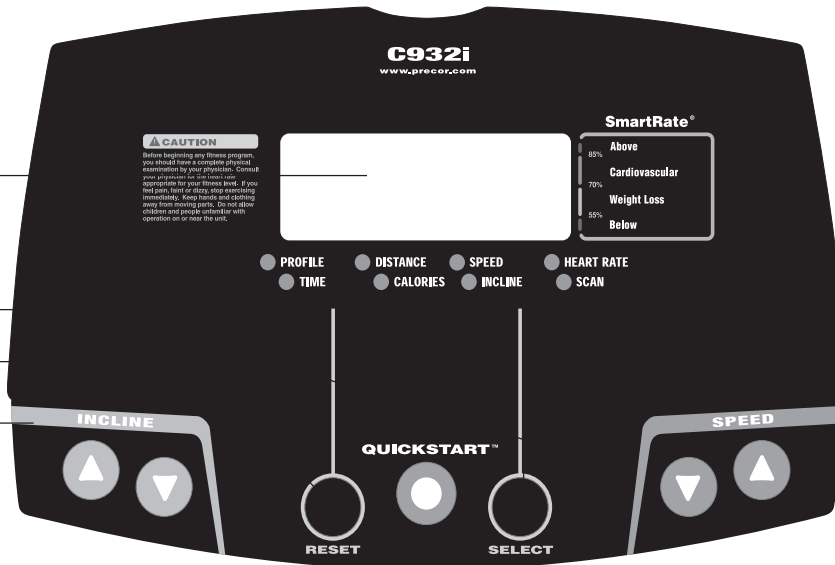

## PROGRAMMING TIPS

Certain aspects of the C932i are hidden and can only be accessed using special key presses. To avoid unauthorized use, certain rules apply. See Diagram 16. Tips to consider while programming or viewing diagnostic information are shown below:

- Always start at the scrolling PRECOR banner.
- The advanced programming and diagnostic mode is accessed by pressing the RESET key (or the red STOP button) while the PRECOR banner is displayed. A second key press must occur within 1/2 second after pressing RESET (or the red STOP button) or the display returns to the PRECOR banner. The third and subsequent key presses must occur within four seconds of the previous key press or the PRECOR banner returns and you will need to begin again.

Display key functions within the Club Custom Mode	
▼▲	lets you scroll through the various selections that appear. The longer the key is held down, the faster the numbers scroll past.
red STOP button	advances to the next aspect of the program without storing the information that appears on the display.
<b>RESET</b>	exits Club Custom mode and displays the PRECOR banner.
<b>SELECT</b>	saves the information being displayed and moves to the next aspect of the program.
<b>QUICKSTART</b>	disabled.

- Exit the programming or diagnostic mode by pressing RESET. Note that the display remains blank for one second and any additional key presses are ignored during that second.

## SELECTING THE LANGUAGE

Display prompts can appear in English, German, Spanish, French, Dutch, or Portuguese. Use the ▼▲ keys to display your preference and press SELECT.

## DETERMINING THE UNITS OF MEASURE

The C932i can display units of measure in either U.S. Standard (miles, miles per hour) or Metric (kilometers, kilometers per hour). When the treadmill is shipped from the factory it is set to display U.S. Standard units of measure. You can easily change this setting by taking the following steps:

1. Check that the C932i is ON. If necessary, turn ON the treadmill using the power switch located at the front of the unit.
2. At the scrolling PRECOR banner, press the following keys in sequence:

**RESET, SELECT, SPEED ▼, SELECT, INCLINE ▲, SELECT, SPEED ▼, SELECT**

Numbers appear associated with the key that you pressed: 5,6,5,1,5,6,5

**Important:** If the second key (SELECT) is not pressed within 1/2 second after RESET, the display returns to the PRECOR banner and you need to begin again.

3. The prompt, SELECT UNITS scrolls across the display and then, the current unit of measure appears. The message scrolls continually until you press a key. Any ▼ or ▲ key lets you alternate between the prompts.
4. Once your selection is displayed, three options exist. You can,
  - a. press the SELECT to accept the unit of measure being displayed and continue with programming the treadmill. (Refer to *Determining the Club Speed Limit.*) The changes are saved in memory. The C932i will retain your selection even when it is turned OFF and unplugged.
  - b. press the red STOP button, which keeps the “current unit of measure”, unchanged and advances to the next section.

**Note:** The “current unit of measure” is not necessarily the one being displayed. It refers to the unit of measure that was in existence prior to entering the SELECT UNITS program.

- c. press RESET, which keeps the “current unit of measure”, unchanged, ends programming mode, and returns to the PRECOR banner.

**Important:** If you change the Unit of Measure display, be sure to check the speed limit setting to verify that it is correct. Refer to *Determining the Club Speed Limit* below.

## DETERMINING THE CLUB SPEED LIMIT

You can set a maximum speed for the treadmill. This limits how fast the running belt moves and, consequently, how many adjustments a user can make to the treadmill's speed. The speed is displayed in miles per hour (mph) or kilometers per hour (kph) depending upon the units of measure (U.S. Standard or Metric) that are selected. Once the prompt SET MAX SPEED scrolls across the display, use the ▼▲ keys to choose a speed between: 0.5 to 11.0 mph (1.0 to 18 kph).

Press SELECT to continue programming the treadmill. Refer to step 4 above.

**Important:** *If you select a number that limits the miles per hour, your change will not affect the kilometers per hour (and vice versa). The treadmill does not convert the speed entered in miles per hour (U.S. standard) to kilometers per hour (Metric). It stores separate numbers for the different units of measure.*

## SETTING A WORKOUT TIME LIMIT

You can limit how long a user works out by setting a duration between 1 and 99 minutes. The treadmill also lets you choose NO LIMIT (found at the zero point between 99 and 1) which allows the user to select a program and work out indefinitely.

**Note:** The QUICKSTART program is automatically limited to the Club limit. For example, if you set the workout time limit to 20 minutes, the treadmill allows users to specify a workout between 1 and 20 minutes. Users cannot specify a time longer than 20 minutes.

**Important:** *An exception to the rule is the Weight Loss program. It has a duration of 28 minutes.*

Use the ▼▲ keys to select a workout time limit. Touch either ▼▲ key and the display changes in one minute increments. Press and hold the ▼ or ▲ key and the numbers advance or decrease faster. Take into account that the user may get an additional cool-down period appended to his or her workout (depending on program selection), so adjust the maximum time limit accordingly.

Press SELECT to continue programming the treadmill. Refer to step 4 above.

**Note:** If the workout time is set to NO LIMIT users can workout indefinitely and no cool-down is appended to the program. The exception is the Weight Loss program.

## SETTING A PAUSE TIME LIMIT

Setting a pause time limit is useful because the treadmill returns to the PRECOR banner at a selected interval after the red STOP button is pressed.

After the reading the scrolling prompt and message, use the ▼▲ keys to set the pause time limit between 1 and 120 seconds (two minutes).

Press SELECT to continue programming the treadmill. For other options, refer to step 4 on the previous page.

## SETTING A COOL DOWN TIME LIMIT

You can set a limit to the duration of a user's cool down time in one-minute increments. It is highly recommended, in most workout literature, that a user cool down for at least three minutes to allow their heart rate to return to a "normal," non-exercising state. A cool down period also allows lactic acid, which may have built up in a person's body during a workout, to dissipate somewhat during the cool down phase.

After the scrolling prompt appears, use the ▼▲ keys to set a cool down time limit between 1 and 5 minutes.

Press SELECT to accept the displayed value and return to the PRECOR banner. For other options, refer to step 4 on the previous page.

## VIEWING THE ODOMETER, HOURS OF USE, SOFTWARE VERSION, ERROR LOG, AND SERIAL NUMBER

*Important:* Review *Programming Tips* on the previous page before taking the following steps.

To view the odometer, the number of hours that the running belt has been in use, the C932i software version number, or the error log, begin at the PRECOR banner and press the following key sequence:

### RESET, SPEED ▼, SELECT

The numbers 6, 5 appear on the display as you press the associated key.

The field name MILES or KILOMETERS scrolls across the display and indicates the unit of measure currently in use by the treadmill. The odometer value appears next. The odometer tracks the running belt movement. The numeric value that appears indicates the distance traveled in cumulative miles or kilometers. The message continues to scroll until you press a key. Refer to *Programming Tips* on page 22.

Press the SELECT key and the word HOURS scrolls across the display. The number that follows indicates the hours of that the running belt has been in use. The C932i actually notes the passing of program minutes, but the numeric value that appears is truncated to the nearest full hour.

Press SELECT again and the unit's three digit software version number (upper display software version) scrolls past followed by the lower board's software version number. The words "UPPER SW:" and "LOWER SW:" appear prior to the version being displayed.

C O M M E R C I A L P R O D U C T S D I V I S I O N

Press SELECT once again and the Error Log appears. The most recent error log appears first and scrolls across the display. If the words, NO ERRORS appear, no errors have been recorded.

Up to ten error codes can be recorded and viewed in the following format.

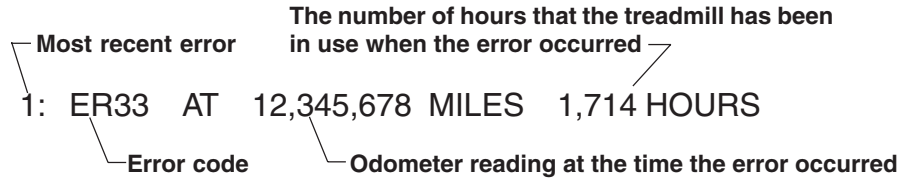

**Note:** To clear (delete) the error log, press the QUICKSTART key for at least four seconds while the message HOLD QUICKSTART TO CLEAR ERROR LOG scrolls across the display. If the QUICKSTART key is released before the message finishes scrolling, then the display returns to the previous error code. If you continue to press the QUICKSTART key until the message finishes scrolling, then prompts appear on the display and let you know when the error messages have been deleted from memory.

**Important:** You cannot retrieve the error log once you have deleted it.

To view the serial number, press SELECT. Write the serial number onto the warranty registration form on page 54 and in the space provided on page 7. The serial number is helpful should you ever need to contact Customer Support.

To return to the Precor banner, press RESET or the red STOP button.

## The C932i Display

The C932i is designed so users can work out with minimal instruction or training. The directions on the console and the prompts on the display will guide a user through the entire workout session. Before the treadmill is used, however, we recommend that you, as club owner or manager, familiarize yourself with it so you can instruct your customers to use it safely and effectively.

This section covers the following information:

- an overview of the different features provided on the display console
- an explanation about the Setup Mode and Display Prompts
- instructions for using the heart rate options

### FEATURES ON THE DISPLAY CONSOLE

As a user works out, the display consecutively scans through the highlighted features [PROFILE, TIME, DISTANCE, CALORIES, SPEED, INCLINE, HEART RATE (HR) and SmartRate®]. Indicator lights appear next to the feature being displayed. A user can change which features appear by pressing the SELECT key. Refer to *Changing the Display Features Using the SELECT Key* on page 35.

Diagram 17 shows the display console label. Its display features and keys are explained on the following pages.

**Diagram 17**  
C932i display console

**SmartRate® display**  
**Program profile and data entry fields**  
*Once you begin a program, the profile appears in this portion of the display and remains until the scanning process begins.*

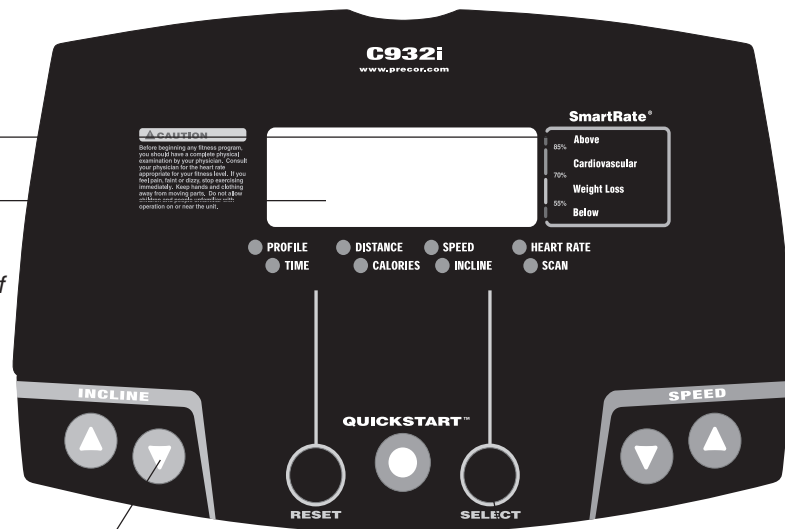

**Keypad keys**  
*The keys on the keypad let you:*

- control your workout session,
- answer prompts prior to starting a program,
- determine which display features appear,
- prematurely end a program, and
- adjust the incline and speed.

*Refer to Keys on the Keypad on page 33.*

**SELECT key**  
*Customize the display by highlighting an LED indicator. Make your selections by pressing the SELECT key. A lit LED indicates which feature is being displayed.*

The SmartRate® and Heart Rate system is standard equipment. The heart rate receiver is factory-installed in the display console. To actively view the SmartRate® and heart rate displays, a user must wear a chest strap, face the display console, enter his or her age (during the Setup prompts), and begin a program. The user's heart rate is transmitted from the chest strap to the receiver inside the console and appears on the display. A blinking segment approximates the user's heart rate and shows which zone the heart rate is in: weight loss or cardiovascular.

**Important:** During a program, a user's heart rate must be above 40 beats per minute before the segment begins to blink. Note that pressing QUICKSTART at the PRECOR banner causes the SmartRate® display feature to be inactive.

## SETUP MODE AND PROMPTS

The PRECOR banner is the “starting point” when a user begins a workout. If the banner does not scroll across the display, press the RESET key. If the display appears blank, make sure that the treadmill is turned ON. Press the ON/OFF [I/O] switch located at the front, near the power receptacle, to ON.

**PRECOR banner:** From the PRECOR banner, a user presses the SELECT key to access the Setup mode which lets a user determine the program, workout time, weight, and age parameters as described below.

**Note:** Key presses to the INCLINE ▼▲ or SPEED ▼▲ keys are ignored when the banner is being displayed. Refer to page 31 for more information about the keypad.

**MANL:** The program prompt, MANL, indicates that the C932i is ready to accept program entries. To help a user determine which program they want to use, the program names and profiles appear on the display console label. The ▼ and ▲ keys let a user scroll through the available programs. The display presents the abbreviated name of the program. To choose the selection being displayed and continue in Setup mode, press SELECT. (Refer to *The Setup Mode and the QUICKSTART Feature* on page 29.)

**Note:** Depending on the program that is selected, a user may be prompted for other information. Refer to *C932i Programs* on page 42.

**XX MIN:** Acceptable entries at the workout time prompt range between NOLIM (zero) and 99 minutes. Use the ▼ and ▲ keys to change the selection. If the club allows it and a user wants to work out indefinitely, they can choose NOLIM. A cool-down period will not be appended to the program. Note that the Weight Loss program has a preset time limit so a user will not be prompted for a workout time when they choose WTLS. A user cannot workout indefinitely in the Weight Loss program.

To continue in Setup mode, press SELECT.

**Important:** The club has the option to set limits on program duration and cool down and pause time. Refer to *Club Information* on page 21.

**150 LB (68 KG):** Acceptable weight entries range from 1 through 999 (pounds or kilograms). Change the number using the ▼ and ▲ keys or accept the displayed number (and continue in Setup mode) by pressing SELECT.

**Important:** Enter a number that reflects a user's actual weight since the calorie count and several other calculations are based on the weight entry.

**AGE 0:** The age prompt appears if the heart rate receiver is properly installed in the display console. Acceptable entries range from 1 to 99. Change the blinking number using the ▼ and ▲ keys or accept the displayed number by pressing SELECT.

**Important:** An age entry is required if the user wants to use the heart rate capabilities of the treadmill. Refer to Heart Rate Capabilities on page 45.

## THE SETUP MODE AND THE QUICKSTART™ FEATURE

The QUICKSTART feature can be pressed any time during the Setup prompts. Since the QUICKSTART program accesses factory default values (refer to *Club Information* on page 21) and assumes the age value is equal to zero, the SmartRate program is disabled. However, the values that the QUICKSTART program uses are dependent on when a user presses QUICKSTART in the Setup mode. See the table below.

**CAUTION:** Pressing the QUICKSTART key at the PRECOR banner or after any one of the Setup prompts causes the running belt to begin moving automatically. Hold onto the handrail because the belt starts moving after a short warning message scrolls across the display, “Belt Starting 3, 2, 1...”

If QUICKSTART is pressed at the:	The following occurs:
PRECOR banner	The user bypasses the Setup prompts altogether and starts working out using the Manual program. Default values apply.
Program prompt	The profile associated with the program name (MANL, INTV, WTLS, etc.) appears on the display and becomes the user's selection for their workout.
Workout Time prompt	The information (XX MIN) that appears on the display becomes the workout time for the program. A user can change the display using the ▼ or ▲ keys. See <i>Workout Tips</i> .

**Note:** A user can select an indefinite workout time, if the Club allows it. By pressing either ▼▲ key, the word “NOLIM” appears on the display where the number zero would normally appear (between 99 and 1). Refer to *Club Information* on page 21.

Table continued...

**If QUICKSTART is pressed at the:    The following occurs:**

Weight prompt	The weight (150LB or 68KG) that appears on the display becomes the designated weight that the C932i uses to compute various calculations. A user can change the display from 1 through 999 using the ▼ or ▲ keys.
Age prompt	The age prompt (AGE 0) that appears on the display becomes the designated age that the C932i uses for SmartRate® system. A correct age entry between 1 and 99 is very important if a user plans to use the heart rate characteristics of the treadmill. The QUICKSTART key acts the same as the SELECT key at this point because the user has answered all the Setup prompts.

**CENTER DISPLAY DURING A WORKOUT**

The PRECOR banner, setup prompts, program profiles and feature selections appear in the center display. Prior to working out, prompts guide the user through the Setup mode. Refer to *Setup Mode and Prompts*.

Once a user begins a workout, the SCAN LED is lit indicating that all highlighted features (PROFILE, TIME, DISTANCE, etc.) will appear consecutively on the display. A user can change what features are scanned by pressing the SELECT key. Refer to *Changing the Display Features Using the SELECT Key* on page 35.

The following describes the information that can appear in the display.

**PROFILE:** At the beginning of a program, the profile appears on the right side of the display and corresponds to the program that has been selected. As a user proceeds through the workout, a blinking column indicates his or her position in the program. The height of the column indicates the level of incline. Every time the incline changes by several sequential levels (up or down) the height of the column changes by one cell.

**TIME:** A time (0:00) display appears when a user begins working out. TIME appears in minutes and seconds. However, should a user exceed 60 minutes (during a single workout), the TIME display converts to hours and minutes. Most often, the TIME display shows the amount of time remaining in a workout.

**DISTANCE:** The distance that a user has traveled appears (00.00) once a workout begins. Distance can appear in miles or kilometers. If the user wishes to change the display, they will need to contact the club manager or owner. Refer to the instructions found in *Club Information* on page 21.

**Note:** If a user were to exceed 65.53 miles (or kilometers) in a single workout, the numerical display resets to zero and begins over again.

**CALORIES:** Provides an estimate of the cumulative number of calories burned. The calorie calculation is derived from the speed, incline level, and a user's weight. An accurate weight entry results in a more accurate calorie count.

**SPEED:** Displays the running belt's speed. The ▼ and ▲ keys let a user decrease or increase the treadmill's speed. The running belt speed ranges from 0.5 to 11.0 mph (1.0 to 18.0 kph) and can be changed in 0.1 increments.

**Note:** A user can check the speed (when it is not the chosen display) any time during a workout by tapping either SPEED ▼ or ▲ key. Pressing and holding the SPEED ▼ or ▲ key causes the treadmill's speed to change. Refer to *Keys on the Keypad* on page 33.

**INCLINE:** Displays the percent of incline during a workout. The INCLINE ▲ and ▼ keys affect the treadmill's lift and let a user set an incline between 0% and 15.0%. The values displayed can change in 0.5% increments.

**Note:** A user can check the incline (when it is not the chosen display) any time during a workout by tapping either INCLINE ▲ and ▼ key. Pressing and holding the INCLINE ▲ and ▼ key causes the treadmill's incline to change. Refer to *Keys on the Keypad*.

**HR:** The heart rate display lets a user monitor his or her heart rate. When a heart beat is detected, the number appears when the display scans HR (Heart Rate). The indicator (LED) light next to the HR label pulses whenever the heart rate receiver detects the user's pulse. If a user is not wearing a chest strap, the heart rate will not be detected and no pulse rate appears (the display remains blank).

**Important:** If a “— — —” appears in the display, the C932i is having difficulty detecting a user's heart rate. Make sure that the chest strap is positioned properly on a user's chest against the skin. If the heart rate receiver in the display console has become disconnected, the display appears blank. Refer to the *Heart Rate Capabilities* on page 45.

**SmartRate®** display: Once a program begins, a blinking column segment along the right edge of the display approximates a user's heart rate and shows which zone the user's heart rate is in: weight loss or cardiovascular.

- **Weight Loss Zone:** Maintaining a heart rate between 55% and 70% of a user's maximum aerobic heart rate, helps burn enough calories that, when continued on a regular basis for 30 minutes or more, provides the greatest fat-burning results. The yellow LED's on the SmartRate® display indicate the Weight Loss zone.
- **Cardiovascular Zone:** Maintaining a heart rate between 70% and 85% of a user's maximum aerobic heart rate, helps (when continued on a regular basis for 30 minutes or more) improve a user's overall cardiovascular/cardio-respiratory fitness level. The green LED's on the SmartRate® display indicate the Cardiovascular zone.

## The C932i Keypad

The C932i keypad allows a user to control the workout session. Information that you will find in this section includes:

- Tips on using the display keypad
- Descriptions of each key on the keypad
- How to use the SELECT key to change which features appear on the display

### KEYPAD TIPS

Review the following tips and make sure that your customer's know how to use the keypad.

- Accurate entries are required or features such as SmartRate® will not work properly.
- During the Setup prompts, a user can change the information being displayed by pressing any ▼ or ▲ key. (Incline and speed levels are not affected until the program begins.)
- Press SELECT to “select” the information being displayed.
- Pressing QUICKSTART at the PRECOR banner bypasses further selections and displays the Manual (MANL) program. Default values apply. The SmartRate® display will not appear. Refer to *The Setup Mode and the QUICKSTART™ Feature* on page 29.
- Anytime during the setup or workout, press RESET to return to the PRECOR banner.
- A time-out occurs during the Setup prompts if the C932i detects no key presses for two minutes. The display returns to the PRECOR banner.

### SPECIAL KEYPAD FUNCTIONS AT THE PRECOR BANNER

A variety of tasks can be performed from the banner using different key presses:

**Note:** Key presses to the ▼ or ▲ key are ignored when the banner is being displayed.

RESET — initiates the diagnostic mode. Refer to *Club Information* on page 21.

QUICKSTART™ — causes the system to start the Manual (MANL) program. Default settings apply. Refer to *The Setup Mode and the QUICKSTART Feature* on page 29.

SELECT — initiates the Setup mode and causes the program prompt to appear.

**Diagram 18**  
C932i keypad.

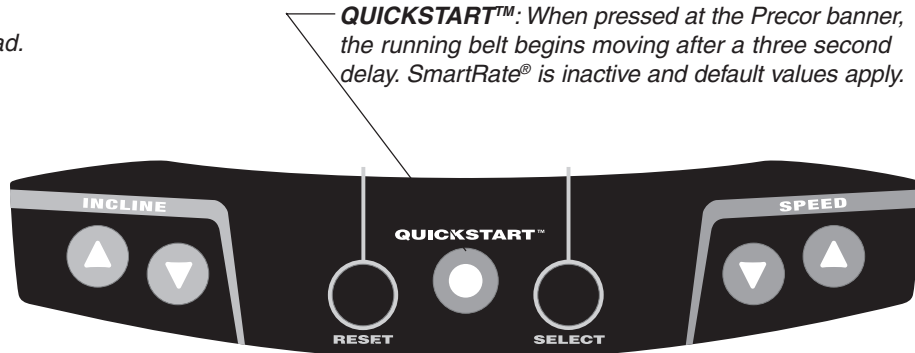

**Keypad keys**

The keys on the keypad let you:

- control your workout session,
- answer prompts prior to starting a program,
- determine which display features appear,
- prematurely end a program, and
- adjust the incline and speed levels.

**KEYS ON THE KEYPAD**

The following information explains the different uses of the keys from left to right. To locate each key, look at the display console or refer to Diagram 18.

**INCLINE ▲▼:** During a workout, the INCLINE ▲▼ keys let you increase or decrease the incline in 0.5% increments. The display can show a range from 0 to 15%. Setting 0 is level (and the lowest) incline.

When a user changes the incline by pressing the INCLINE ▲ or ▼ key, the number that appears on the display shows the *target* incline (not necessarily, the present incline) because the display can change much faster than the treadmill's lift.

**Note:** Any time during a workout, a user can view the actual incline by lightly touching either INCLINE ▲ or ▼ key. A user can opt to change the incline, if they hold the key down for more than one second.

During Setup mode, the INCLINE ▲▼ keys are used for data selection. Pressing either ▲ or ▼ key does not affect the incline. However the ▲ or ▼ keys do affect what appears on the display. Refer to *Setup Mode and Prompts* on page 28.

**RESET:** Provides access to diagnostics (see *Club Information* on page 21) and lets the user access the Workout Summary display while in Pause mode. Refer to *Pause, Workout Summary, and Exit Features* on page 40. Note that if the user presses RESET during the Setup mode, the user exits Setup mode and the PRECOR banner returns.

**QUICKSTART:** This key lets a user bypass the Setup prompts and start their workout immediately using the Manual (MANL) program. The QUICKSTART key can be pressed any time during the Setup prompts. For more information, refer to page 29, *The Setup Mode and the QUICKSTART Feature*.

When a user presses **QUICKSTART** at the PRECOR banner, the default values shown below apply.

**QUICKSTART Default Values**

Setup Prompts	Default Value
Program	Manual (MANL)
Workout time	Club limit
Weight	150 lbs. (68 kg.)
AGE 0 :	A valid AGE must be entered to use the SmartRate® display. If QUICKSTART is pressed <b>after</b> an age is entered, then the SmartRate display will appear when a user wears the chest strap. If no “Age” entry occurs, then SmartRate LED’s light but are not activated. Note that the chest strap is available through your Precor dealer. Refer to <i>Obtaining Service</i> on page 7.

**SELECT** key: While the PRECOR banner is displayed, the SELECT key accesses the Setup mode. Refer to *Setup Mode and Prompts* on page 28. During a program, the SELECT key changes what features appear on the display. To learn about which features appear on the display or setting up an automatic scan of the workout data, refer to *Changing the Display Features Using the SELECT Key*.

**SPEED ▼▲**: During a workout, the SPEED keys let a user decrease or increase the running belt’s speed. The display can show a range from 0.5 to 11.0 miles per hour (1.0 to 18.0 kilometers per hour) and changes can be made in 0.1 increments.

When a user changes the speed by pressing the SPEED ▲ or ▼ key, the number that appears on the display shows the *target* speed (not necessarily, the present speed of the running belt) because the changes to the display can occur much faster than the belt speed.

Any time during a workout, a user can view the actual speed by lightly tapping either SPEED ▲ or ▼ key. The “pace” (minutes per mile) appears in the left-most display. A user can opt to change the speed, if they hold the key down for more than one second.

During Setup mode, the SPEED ▲ ▼ keys are used for data selection. Pressing either ▼ or ▲ key does not affect the running belt. However the ▲ or ▼ keys do affect what appears on the display. Refer to *Setup Mode and Prompts* on page 28.

**STOP** button: The red STOP button is not part of the keypad, but it is an integral part of the display console. Anytime during a workout, a firm tap on the red STOP button slows the running belt to a stop. The treadmill retains a user’s workout statistics and enters Pause mode. The club has the ability to limit the amount of time a user can remain in pause mode. Refer to *Club Information* on page 21.

For a user to resume working out within the time frame allotted, he or she can press the SPEED ▲ until the desired speed of the running belt is reached.

## **CHANGING THE DISPLAY FEATURES USING THE SELECT KEY**

The SELECT key lets a user choose which feature(s) appears on the display. When a user begins a program, the display automatically scans all highlighted features. The indicator light (LED) next to the SCAN label is lit.

To turn off the scanning feature entirely, a user can switch the indicator lights, next to the item, on or off. If the indicator light is off, the item will not appear in the display.

To turn the indicator lights on or off, take the following steps:

1. Press the SELECT key until the indicator next to the item's label is lit. If a user turns an item "ON," the indicator light next to the item remains lit and the featured information continually appears on the display. The SCAN LED turns off indicating that the display is no longer scanning all the features.
2. To reset to scan mode, press the SELECT key until the SCAN LED is lit.

## Exercising on the C932i

Once the C932i is set up, it is ready to use. The easy-to-understand prompts let the user select a program and specify how long he or she wishes to work out. The speed and incline levels can be adapted to meet their fitness goals.

**Important: Club owners, managers, and personal trainers.** Remind users how important it is to use the treadmill's safety features and security clip while working out on the treadmill. Instruct them on how to attach the security clip to their clothing near their waistline. If any complications occur, a strong tug on the security cord or a quick tap on the STOP key will stop the running belt.

**Note:** This section of the manual is written for the user because it specifically explains how to work out on the treadmill. References are made in second person.

Information presented in this section includes:

- Using the safety features
- Quick steps to working out
- Reviewing keypad and workout tips
- Cooling down, pause and exiting features

**CAUTION: Do not allow children on or near the treadmill. If anything should get caught in the rollers, the running belt does not stop immediately.**

### SAFETY FEATURES

The C932i treadmill is a powerful machine. Safety aspects to consider include:

- Always hold onto the handrail whenever you step on to or off of the treadmill.
- Always attach the security clip to your clothing prior to working out.
- Prior to the start of a program, the display will return to the PRECOR banner if more than two minutes elapse without a key press occurring.

### USING THE SECURITY CLIP

A security clip is attached, by its cord, to the red STOP button that straddles the handrail. **Always attach the security clip to your clothing before each workout.** A tug on the cord trips the security switch and slows the running belt to a stop. If the security switch trips while you are working out, the treadmill retains your workout statistics and enters Pause mode. To resume your workout, reattach the security clip to your clothing, and press the SPEED ▲ key until you reach the desired speed.

### USING THE HANDRAILS

Always grasp the handrails to help keep your balance when stepping on to or off of the treadmill and when you press the display keys.

**CAUTION: When you press the QUICKSTART key, keep in mind that the running belt begins moving automatically at 1.0 mph or 1.5 kph following the scrolling prompt: BELT STARTING 3, 2, 1... Other programs, such as the Interval (INTV) program have user-defined speeds. Prior to a change in speed, a three-minute warning scrolls across the display. Always grasp a handrail when the running belt changes speeds. Do not let go until you are comfortable with the running belt speed.**

## USING THE RED STOP BUTTON

The red STOP button is not part of the keypad, but it is an integral part of the treadmill's safety features. Anytime during a workout, a firm tap on the red STOP button or a tug on the security cord slows the running belt to a stop. The treadmill retains a user's workout statistics and enters Pause mode. Refer to *Pause, Workout Summary, and Exit Features* on page 40.

**Important:** During a workout, if a user makes a mistake in pressing the red STOP button, they can immediately press the SPEED ▲ to resume the speed of the running belt where they last left off.

## REVIEWING KEYPAD AND WORKOUT TIPS

The steps to working out on the treadmill are listed on the opposite page. A short description appears in the left margin with the more thorough explanation following on the right. Tips to consider during your workout are shown below:

### Keypad Tips

▼ or ▲ — presses to the arrow keys are ignored when the PRECOR banner is being displayed.

SELECT — initiates the Setup mode. You can change the display selections using the ▼ or ▲ keys.

QUICKSTART — bypasses further selections and causes the running belt to move. Default values apply (see QUICKSTART on page 34). The SmartRate® display is not active.

RESET — exits the Setup mode and returns to the PRECOR banner.

### Workout Tips

- Always attach the security clip to your clothing prior to working out.
- Check that the banner, PRECOR, is scrolling across the display.
- Accurate entries are required or features, such as SmartRate®, will not work properly.
- A time-out occurs during the Setup prompts if the C932i detects no key presses for two minutes. The display returns to the PRECOR banner.
- At the beginning of a workout, take several minutes to bring your heart rate into your target zone. Refer to Diagram 20 on page 46.
- After your workout, walk slowly for several minutes to help lower your heart rate. If possible, use the cool-down feature on the treadmill.
- Before and after a workout, gently stretch your lower body and back to help prevent stiffness or soreness.

## QUICK STEPS TO WORKING OUT

When you first turn the unit ON, the PRECOR banner scrolls across the display. This banner indicates that the C932i is ready to accept user entries.

- |  |   |
|--|---|
| <p><b>1</b> ▶ <b>Put on the chest strap.</b><br/>(Part of the Precor Heart Rate Option.)</p> | 1. To use the heart rate capabilities in the C932i treadmill, you need to wear a chest strap during your workout.   |
| <p><b>2</b> ▶ <b>Straddle belt.</b></p>  | 2. Make sure that the PRECOR banner scrolls across the display. Straddle the running belt with your feet firmly planted on the right and left staging platforms. Stand close enough to the display console so that you can extend your arms and touch the keys. |
| <p><b>3</b> ▶ <b>Attach security clip to clothing.</b></p>                                   | 3. Attach the security clip to your clothing near your waistline.   |
| <p><b>4</b> ▶ <b>Face the display and select a program.</b></p>                              | 4. Face the display and hold onto the handrail with one hand when you press the keypad with the other. There are several different paths you can take to move through the Setup mode. How you set up your workout depends on how detailed you like to be.       |

While the PRECOR banner scrolls, do one of the following:

- **Press SELECT** — By pressing SELECT, the MANL (Manual) program selection appears. To select a different program, use the ▼▲ keys. When your preferred program appears, press SELECT. If the program selection lets you designate a workout time, the XX MIN (time prompt) appears. Use the ▼▲ keys to select a time between NOLIM (zero - no time limit) and 99 minutes.

**Note:** The club has the ability to limit the duration of a workout.

Continue this process to enter or change your WEIGHT (1 through 999 pounds or kilograms) and AGE (1 through 99).

- **Press QUICKSTART** — By pressing QUICKSTART at the PRECOR banner, you access the MANL (Manual) program. You can also press QUICKSTART during Setup mode to process any selection that appears on the display and any prior entries you may have made.

**CAUTION: Hold onto the handrail because the belt starts moving after a short warning message appears on the display, “Belt Starting 3, 2, 1,…”**

- |   |  |
|---|--|
| <p><b>5</b> ▶ <b>Begin working out.</b></p> <p><i><b>Note:</b> Any time during the Setup prompts, you can press the QUICKSTART key. Refer to QUICKSTART on page 34.</i></p> | 5. If you pressed SELECT to answer all the Setup prompts, hold onto the handrail with one hand while you press the SPEED ▲ key with the other hand. Step onto the running belt while the speed is at 1 mph (1.5 kph). Once you are comfortable with the walking or running speed, you can remove your hands from the handrail. |
|---|--|

- 6** Change speed or incline during your work out.
- (Pause)
- 7** Cool down.
- 8** End your workout.
- (Review WORKOUT SUMMARY)
- 9** Remove the security clip and step off the treadmill.
6. Use the INCLINE ▼▲ and SPEED ▲▼ keys to change the incline and speed during your workout. Note that certain programs have preprogrammed speed and incline changes. Refer to *C932i Programs* on page 42.
- Note:** To pause during your workout before finishing the selected program, press the red STOP button. The displays on the console freeze. To return to your workout, press the SPEED ▲ key until you reach the desired speed.
7. A workout ends when you complete the time limit set for the program or you press the red STOP button and enter pause mode. When you complete the time limit set for the program, you enter the cool-down period. Use ▼ or ▲ keys to decrease or increase the speed and incline during your cool-down period.
- Important:** Always incorporate a cool-down period into your workout. If you press the red STOP button to end the program, select the MANL (Manual) program to cool down. Refer to *Pause, Workout Summary, and Exit Features* on page 40.
8. When you complete the cool-down period, the running belt stops and a WORKOUT SUMMARY banner appears. Note that the TIME display shows the accumulated workout time including warm-up and cool-down periods.
- Note:** You are given a few minutes to review your workout summary before the display automatically resets to the PRECOR banner.
9. Hold onto a handrail and place your feet on the right and left staging platforms, remove the security clip from your clothing, and step off the treadmill.

## COOLING DOWN AFTER YOUR WORKOUT

Cooling down is an important aspect of your workout because it helps reduce muscle stiffness and soreness by transporting excess lactic acid out of the working muscles. Cooling down for at least three minutes helps provide a smooth transition that allows your heart rate to return to its normal (non-exercising) state.

When you enter cool down, a message notifies you that you have reached the end of the program and the cool-down period is about to begin. The running belt slows by about 20 percent and the incline returns to 0 percent. The Manual program profile appears in the display. You can change the speed and incline by pressing the respective ▼ or ▲ keys. When you complete the cool-down period, a workout summary appears. See the information beginning on page 40.

**Important:** The automatic cool-down period does not occur if the selected workout time is NOLIM. In any other program, the automatic cool-down period is activated when you complete the program. If you exit a program prior to its completion, then the cool down program is not implemented.

To prematurely end the cool-down period, press the red STOP button and then RESET. Refer to the table on the next page. Your workout statistics are added to the cumulative totals while the running belt slows to a gradual stop. The WORKOUT SUMMARY display appears so you can review your cumulative totals.

The following information shows what happens when you press certain keys while in the cool down mode.

While in cool down, you press	This is what happens...
-------------------------------	-------------------------

STOP	Enters Cool down - Pause mode. The running belt slows to a gradual stop. TIME stops incrementing. The display features remain, so you can review your workout statistics. Note that you may also press the SPEED ▼ key until the belt slows to a gradual stop.
------	--

**Note:** The club can limit the amount of time that you can pause during a workout.

While in Cool down-Pause mode, you press	This is what happens...
--	-------------------------

SPEED ▲	Starts the running belt moving again and returns to cool down mode so that you can resume where you left off. TIME continues to count down.
---------	---

RESET	Displays the workout summary banner.
-------	--------------------------------------

**PAUSE, WORKOUT SUMMARY, AND EXIT FEATURES**

Pausing and exiting are integral parts of your workout and can be accessed any time during a program. The treadmill goes through several prerequisites before actually exiting a program.

**Pause mode** — can be accessed while in a program or during cool down. Note that the Pause mode can be of limited duration (between 1 second and 2 minutes). Check with the Club manager. If no key presses occur during that time, the workout statistics are added to the cumulative totals and the display returns to the PRECOR banner.

**Workout Summary display** — provides a two minute time frame in which you can review your workout statistics before the display automatically resets to the PRECOR banner. The WORKOUT SUMMARY display can be accessed from the Pause or Cool Down/Pause modes, or by prematurely exiting a program. When the display appears, workout statistics except TIME, DISTANCE and CALORIES reset to zero. (Note that the TIME and CALORIES displays show the accumulated workout time and expended calories including warm-up and cool down periods.)

The following information shows what happens when you press certain keys while in the various modes.

**During a program, you press      This is what happens...,**

**STOP**      Enter Pause mode. The running belt slows to a gradual stop. Note that you may also press the **SPEED ▼** key until the belt slows to a gradual stop. Once the running belt stops, **TIME** stops accruing. The display features remain, so you can review your workout statistics. The Pause mode has a maximum two minute time limit, but the club can set a lower limit.

**While in Pause mode, you press      This is what happens...,**

**SPEED ▲**      Exits Pause mode and starts the running belt moving again so that you can resume the program where you left off.

**RESET**      Displays the workout summary banner so that you can view your workout statistics.

**At the Workout Summary banner, you press      This is what happens,...**

**RESET**      Returns to the **PRECOR** banner.

**Note:** If the two minute time limit elapses, the display returns to the **PRECOR** banner.

## C932i Programs

A variety of exercise options are available on the C932i. This section provides:

- Descriptions of the programs printed on the display console label
- A more detailed look at the SmartRate® and heart rate features

### PROGRAM FEATURES

- If the club allows it, you can work out indefinitely in any program (except Weight Loss). At the XX MIN prompt, select NOLIM.

**Important:** *The automatic cool-down period is not appended to programs where the duration is NOLIM.*

- Place a time limit on any program during the Setup prompts. At the XX MIN prompt, indicate the duration of your workout. When you complete the program, the automatic cool-down period begins.
- Determine the speed and incline as you move through program.
- SELECT programs with preset inclines. In Weight Loss\* and Heart Rate Control\* and Random programs, the incline automatically changes as you progress through the program profile. You have complete control over the running belt speed. You can also override the incline using the INCLINE ▲▼ keys for each upcoming segment in the program profile. The profile changes accordingly and the incline position is saved until a different program is used. When you complete a program with a time limit, the automatic cool-down period begins.

The progress that you make during a program is tracked by a blinking cursor. If the column is several segments high, the entire column blinks.

- Access to heart rate and SmartRate® capabilities is available when the person exercising wears a chest strap. The SmartRate® indicator lights do not appear if QUICKSTART is pressed as the PRECOR banner scrolls across the display.

The different program names appear on the following pages along with a description of the program features. Refer to Diagram 19 on the next page.

**Diagram 19**  
C932i Program label.

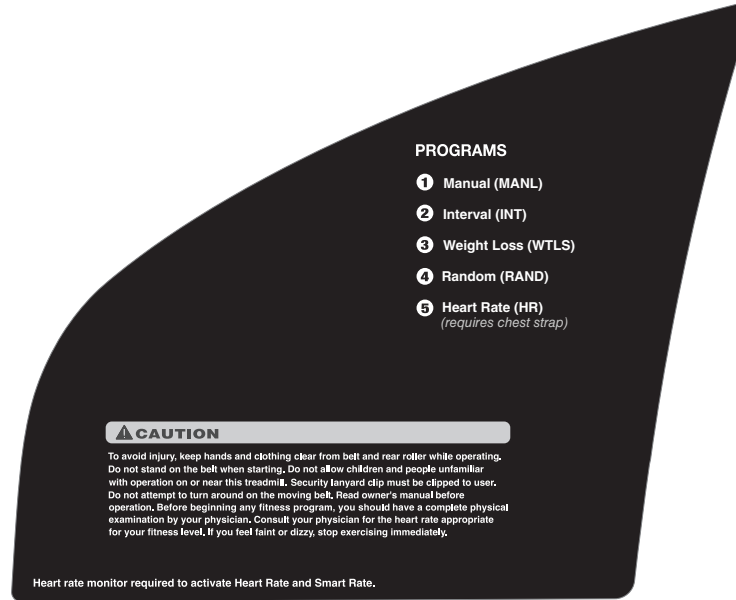

## PROGRAM DESCRIPTIONS

**Note:** The asterisk \* denotes the programs that require the user to wear the chest strap during a workout.

### MANUAL (MANL)

**Program duration:** TIME set by user

In the Manual program, speed and incline changes are completely under your control. The profile is initially a flat line. If changes are made to the incline, the program profile reflects the changes in all subsequent column segments. The blinking cursor indicates your position on the program. If you press QUICKSTART at the PRECOR banner to access the Manual program, the program TIME defaults to the club limit. You need to press the red STOP button when you have completed your workout. Note that a cool-down period does not occur when you press the red STOP button. Always, remember to incorporate a cooling down period into your workout.

**Note:** You have the option to designate a workout time for the Manual program during the Setup mode. For more information, refer to *Quick Steps to Working Out* on page 38.

### INTERVAL (INTV)

**Program duration:** TIME set by user

The Interval program is one of the best for conditioning your cardiovascular system. The program is designed to raise and lower your heart rate in a repeating fashion for a specified period of time. The interval program on the C932i lets you set the rest and work intervals according to your training regimen. You set the speed and incline for the first rest and work intervals and the software takes over from there, repeating the intervals throughout the program until you press the red STOP button.

**CAUTION:** Since the “speed” can be set and saved with Interval and Weight Loss programs, a warning message appears prior to the start of the program (if the set speed is greater than 1 mph or 1.5 kph). Make sure that the security clip is fastened to your clothing near your waistline. Do not proceed with the program, if you are unfamiliar with the set speeds.

**WEIGHT LOSS (WTLS)****Program duration:** TIME preset

In the Weight Loss program, the workout time is fixed at 28 minutes. You are not prompted (during Setup mode) for a workout time after selecting this program. The program consists of seven, four-minute intervals. You can change the incline or speed (using the appropriate ▼ or ▲ key) any time during the four-minute rest or four-minute work interval. When you change the incline level or speed, the software remembers and repeats the settings for the remaining intervals. When you complete the program, the automatic cool-down period begins.

For the ideal “weight loss” range, your heart rate should be between 55% and 70% of your maximum aerobic heart rate. To view the heart rate and SmartRate® features, you must wear the chest strap. Set the incline level and speed so that your heart rate is maintained at 55% during the rest interval and 70% of your maximum aerobic heart rate during the work intervals. The weight loss range correlates to the yellow LED's on the SmartRate® display.

**RANDOM (RAND)****Program duration:** TIME set by user

Every time a Random program is selected, a different program profile appears. The segments that appear in the program profile maintain a set incline that you can override using the INCLINE ▼▲ keys. The incline is preset to zero for the first segment. The maximum incline change allowed between segments is plus or minus 4 percent. If the club lets you set the workout time at NOLIM (no limit), you need to press the red STOP button when you have completed your workout. You will need to access Manual mode to cool down.

**HEART RATE PROGRAM (HRC)\*****Program duration:** TIME set by user

This program lets you set a target for your heart rate. The treadmill adjusts the incline to maintain your target heart rate while you work out. Similar to the Weight Loss program, you must wear a chest strap. For more information, refer to *Heart Rate Control Program* on page 47.

## Heart Rate Capabilities

You can make each program on the C932i a heart rate “interactive” program by monitoring and maintaining your heart rate in the SmartRate® zone best suited for your specific needs. You’ll need to obtain and wear a chest strap to activate the heart rate capabilities.

**Note:** The SmartRate® indicator lights do not appear if you press QUICKSTART as the PRECOR banner is scrolling across the display. Refer to *Features on the Display Console* for more information.

Before using the treadmill’s heart rate capabilities, take time to read the following guidelines.

- Consult with your physician before engaging in any vigorous exercise. Do not use the Heart Rate Control program or the treadmill’s heart rate capabilities until authorized by your physician.
- Slow down and stop immediately if you experience any pain or abnormal symptoms.
- Gently stretch your lower body and back before and after working out to help prevent stiffness or soreness.
- Know your heart rate (pulse) and your physician-recommended heart rate target zone. Individual heart rates vary according to several physiological factors and may not correspond directly with the diagrams and tables provided.
- You should not use the heart rate capabilities if you are taking any medications that either speed up or slow down your heart rate.
- Always face forward on your C932i and use the handrail for balance. Keep in mind that you are wearing sensitive equipment (the chest strap) and upper body movement should be kept to a minimum.
- After putting on the chest strap, be sure that the C932i is ON. Face the display console for a minimum of 15 seconds. This allows the receiver in the console to acknowledge the presence of the transmitter.
- Incorporate a cool-down period into your workout to help lower your heart rate and minimize muscle stiffness or soreness.

### USING THE SMARTRATE® FEATURE

Add the benefit of SmartRate® to every program on the treadmill. Using SmartRate® as a visual cue helps you adjust your exercise routine to suit specific needs. SmartRate® simplifies the correlation between heart rate and exercise. You don’t have to stop concentrating on your workout to find your pulse. It is displayed right in front of you along with the SmartRate® zone. Once you begin a workout, a blinking segment in the bar graph appears on the display, if you indicated your age during the Setup prompts. The blinking segment indicates the zone that your heart rate is in: Weight Loss or Cardiovascular.

**Note to Club owners, managers, and personal trainers:** Review the information that accompanies the Precor Heart Rate System option. It explains how to adjust and use the chest strap.

Diagram 20 Target zones.

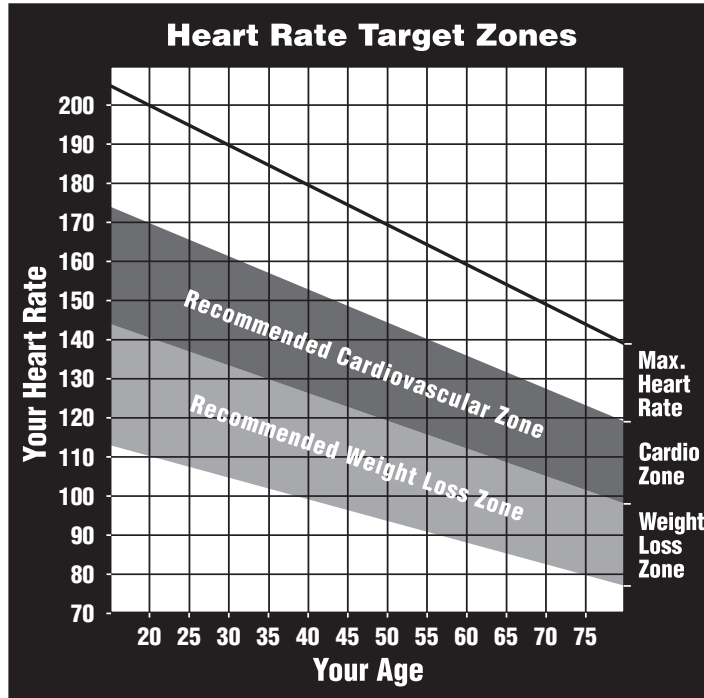

**CAUTION:** Keep in mind that the “Heart Rate” or “target” zones are approximations. Always check with your physician to learn what the appropriate heart rate is for your level of fitness. Do not push yourself beyond the recommended range.

The individual target zones are based on a simple algorithm: 220 minus your age. The algorithm provides a number that estimates your maximum aerobic heart rate. For the ideal “weight loss” range, your heart rate should be between 55% and 70% of your maximum aerobic heart rate. Yellow LED’s light in the SmartRate® display when your heart rate is in the weight loss range.

**Important:** Your heart rate should never exceed 85% of your maximum aerobic heart rate or go above your target zone. Refer to Diagram 20.

When you maintain your heart rate between 70% and 85% of your maximum aerobic heart rate, you are improving your overall cardiovascular/cardiorespiratory fitness level. Green LED’s light in the SmartRate® display appear when you maintain your heart rate in the cardiovascular fitness range.

Maintaining your heart rate in either zone (weight loss or cardiovascular) for 30 minutes or more on a regular basis (minimum 3 times a week) provides the greatest benefits.

## HEART RATE CONTROL PROGRAM

Once you set your target heart rate and the running belt's speed, the Heart Rate Control program monitors your heart rate and automatically maintains it within a few beats per minute (bpm) of the selected target. Blinking lights on the SmartRate® bar graph appear to show the "zone" that you are in.

**Note:** For the C932i to detect a heart rate, you must purchase the heart rate option and wear the cheststrap during a workout.

The chest strap transmits your heart rate signal to the receiver that is installed in the display console. During your workout, the heart rate indicator lights and blinks at the same rate as your pulse. This lets you see what your heart rate is doing even when the display is presenting other workout statistics.

To use the Heart Rate Control program follow the steps found in *Quick Steps to Working Out* on page 38 and choose **HRC** as the program. Enter the workout time, your weight and age. When you begin the program, the following occurs:

- The software verifies that it detects a heart rate signal. You need to press the SPEED ▲ key to begin your workout.

**Note:** If the treadmill is having difficulty detecting your heart rate, three dashes will (- - -) appear in the Heart Rate display. Use the Precor spray that is supplied with the chest strap and readjust the strap around your chest. Make sure that it is against your skin.

- The treadmill provides a three minute warm-up period before entering the Heart Rate Control program. During this time, you may make changes to the incline by pressing the INCLINE ▲▼ keys. Use the SPEED ▼▲ keys to set the running belt's speed.

**Note:** If your heart rate moves into the heart rate zone for your age during the three minute warm-up period, the warm-up period ends and the Heart Rate Control program begins.

- After the warm-up period, the treadmill automatically adjusts the incline to keep your heart rate at the selected target. Pressing the INCLINE ▲▼ keys no longer affects the treadmill's incline, but does affect a change to the *target heart rate*. You can also check the SmartRate® display to see if you are in your preferred zone (cardiovascular or weight loss).

**Note:** You can change your target heart rate or speed anytime during a workout, but doing so affects the treadmill's ability to maintain your target heart rate in the preferred zone. It takes time for the treadmill to readjust the incline so that your heart rate remains on target.

**CAUTION: A warning message will appear if you go above your maximum recommended heart rate target zone. Heed the warning and get permission from your personal physician before working out above the maximum recommended zone for your age and fitness level. See Diagram 20 on the previous page for the recommended target zones.**

- When you complete the program, continue cooling down for the designated period of time.

## Maintenance

The C932i is built to withstand the rigors of the health club environment. However, as club manager or owner, you are responsible for cleaning and maintaining the unit's integrity. If you fail to maintain the treadmill as described below, it could affect or void the Precor limited warranty.

**DANGER** — To reduce the risk of electrical shock, always unplug the unit from its power source before cleaning it or performing any maintenance tasks.

### INSPECTION

Perform a daily inspection of the treadmill.

1. Look and listen for slipping belts, loose fasteners, unusual noises, worn or frayed power cords, and any other indications that the equipment may be in need of service. Obtain service should you notice any of the above.

**Important:** If you determine that the treadmill is in need of service, move it away from the main workout area and place an large "Out of Service" sign on it. While it is awaiting service, remove the power cord so no one can use the treadmill.

2. Check for worn, frayed, or missing safety lanyards. Replace missing or worn safety lanyards immediately. A safety lanyard with its security clip must be fastened to the treadmill's red STOP button. Do not allow users on a treadmill without it.

To order parts or to contact a Precor authorized service provider in your area, refer to *Obtaining Service* on page 7.

### CLEANING THE EQUIPMENT

Most of the working mechanisms are protected inside the treadmill's hood and solid base. However, for efficient operation, the treadmill relies on low friction. To keep the friction low, the treadmill must be as clean as possible.

It is recommended the bed and belt be cleaned daily. Before or after each workout, use a damp, soft cloth to clean the staging platform, running bed and between the belt and running bed surface as far as you can easily reach. This removes any dust or dirt that might affect the smooth operation of the unit.

Periodically, clean the treadmill's frame, display console, handrails and running belt with a dampened (not dripping wet), *clean* cloth using a diluted solution of mild soap and water. To clean the grooves on the belt, use a soft nylon scrub brush. Vacuum the floor underneath the unit every week to prevent the accumulation of dust and dirt.

The Precor Heart Rate equipment requires little maintenance beyond keeping it dust free. Dampen a sponge or soft cloth in mild soap and water to clean the chest strap. Dry the surface thoroughly with a clean towel.

### ALIGNING THE RUNNING BELT

The correct alignment of the running belt is critical to the smooth operation of the treadmill. The belt is properly aligned at the factory. However, during shipping and handling or by use on an uneven surface, the belt may move off center and require a few simple adjustments.

If you plan to align the running belt, check its operation by following the procedure in *Checking the Alignment of the Running Belt* on page 20. If you determine that the belt needs alignment, follow the instructions here.

**CAUTION: Special care must be taken when aligning the running belt. Turn OFF the treadmill while adjusting or working near the rear roller. Remove any loose clothing and tie back your hair. Be very careful to keep your finger or any other object clear of the belt and rollers, especially in front of the roller and behind the deck. The treadmill will not stop immediately if an object becomes caught in the belt or rollers.**

Realigning the belt takes a few simple adjustments. If you are unsure about this procedure, call Precor Customer Support (see *Obtaining Service* on page 7.)

Take the following steps to align the running belt on the treadmill. To ensure your safety, make all adjustments while the treadmill is OFF.

1. Make sure the treadmill is OFF and the running belt has completely stopped.
2. Locate the **left** belt adjustment bolt in the rear end cap of the treadmill. (To determine left and right, stand at the rear of the treadmill and face the display.) The direction you turn the bolt depends on how the belt is tracking. Make all adjustments on the **left rear corner bolt** using the hex key provided.
  - If the belt is off center to the LEFT, turn the adjusting bolt 1/4 turn clockwise, which moves the running belt to the right.
  - If the belt tracks off center to the RIGHT, turn the bolt 1/4 turn *counter-clockwise*; this moves the belt to the left.

**Important:** Do not turn the adjusting bolt more than 1/4 turn at a time. *Overtightening the bolt can damage the treadmill.*

3. Turn ON the treadmill, press QUICKSTART, and then increase the running belt speed to 3 mph (5 kph) by pressing Speed ▲.

**CAUTION: Stand to the side of the treadmill. The running belt begins moving automatically after you press QUICKSTART.**

4. Observe the running belt for a couple of minutes. The belt should be centered on the running bed.

**CAUTION: If you hear any chafing or the running belt appears to be getting damaged, stop the running belt immediately by pressing the red STOP button. Contact Precor Customer Support.**

5. If the belt needs additional alignment, repeat steps 1 through 4 of this procedure until the belt is properly aligned.
6. After aligning the belt, press the red STOP button and RESET. Turn OFF the treadmill. Tighten any loose fasteners or other components on the equipment. If you hear unusual noises or you feel that the treadmill is in need of repair or service, contact Precor Customer Support. Refer to *Obtaining Service* on page 7.

## **SERVICING THE TREADMILL**

Do not attempt to service the treadmill yourself except for the maintenance described in this manual. The unit does not contain any user-serviceable parts that require lubrication. Refer to *Obtaining Service* on page 7.

## **STORING THE CHEST STRAP**

Store the chest strap transmitter in a place where dust and dirt cannot accumulate on it such as, a closet or drawer. Be sure to keep the chest strap protected from extremes in temperature. Do not store it in an area that may be exposed to temperatures below 32 degrees Fahrenheit.

## **LONG TERM STORAGE**

When the treadmill is not in use for any length of time, turn it OFF. Ensure that the power cord is unplugged from the wall outlet and is positioned so that it will not become damaged or interfere with other equipment or people.

**C O M M E R C I A L P R O D U C T S D I V I S I O N**

*Notes:*

**Thank You and Welcome to Precor**



We are confident that you will be pleased with your purchase and that your new Precor equipment will help satisfy your customers' fitness needs, while helping you meet your business goals.

To allow us to serve you better, please take a few moments to complete and return your warranty registration.

**YOU MAY ALSO REGISTER ONLINE AT**  
**[www.precor.com/warranty](http://www.precor.com/warranty)**

If you have questions or need additional information, contact your local dealer or call Precor Customer Support at 800-347-4404.

Fold along dotted line and tape closed before mailing.

COMM.

**PRECOR USA**  
Precor Incorporated  
20031 142nd Avenue NE  
PO Box 7202  
Woodinville, WA 98072-4002

PLACE  
STAMP  
HERE

# TELL US ABOUT YOUR NEW PRECOR PRODUCTS

**Date of Purchase:**

Month	Day	Year
-------	-----	------

**Purchased from (Dealer name):**

--

**Product Serial Number(s):**

--

The serial number is located on the shipping box and on the product.

--

--

Add additional sheets of paper or register online at [www.precor.com/warranty](http://www.precor.com/warranty)

**Please indicate the type and number of products purchased:**

- #: \_\_\_\_\_ Elliptical Fitness CrossTrainer (EFX®)
- #: \_\_\_\_\_ Treadmill                       #: \_\_\_\_\_ Stair Climber
- #: \_\_\_\_\_ Cycle                                       #: \_\_\_\_\_ Strength Station
- #: \_\_\_\_\_ StretchTrainer™

# TELL US ABOUT YOUR FACILITY

--

Name of Facility

- Mr.
- Mrs.
- Ms.

--

Contact Person — First Name

Last Name

--

Facility Address

Apt./Suite:

--

City

State

Zip Code

--

Area Code

Facility Telephone Number

--

Your Business Email Address

**How many members do you have?**

- Less than 100       100 - 500       500 - 1000       1000 - 2000       2001 +

**What percentage of floor space do you allocate for cardio equipment?**

- 0% to 20%       20% to 40%       40% to 60%       60% to 80%       80% to 100%

**What type of equipment makes up your cardio offering (check all that apply)?**

- Treadmills       Ellipticals       Cycles       Stair Climbers       Rowing Machines       Other \_\_\_\_\_

**What other brands of cardio equipment do you currently offer (check all that apply):**

- Life Fitness       True       Cybex       StarTrac       Other \_\_\_\_\_

**What other Precor equipment do you currently offer (check all that apply):**

- EFX®       Cycle       StretchTrainer™
- Treadmill       Stair Climber       Strength Machine       Other \_\_\_\_\_

# TELL US ABOUT YOUR PURCHASE

**Which best describes this purchase (check all that apply):**

- First Precor product
- Replaces same type of product – different brand
- Replaces a Precor product of the same type
- Enhancement to equipment already owned

**How did you FIRST become aware of this product (choose only one):**

- Authorized Precor dealer
- Internet
- Trade/consumer magazine article
- Precor sales representative
- News report or product review
- Other \_\_\_\_\_
- Trade show/conference
- Club/fitness magazine advertisement

**What factors MOST influenced your decision to purchase this product (choose up to three):**

- Precor reputation
- Special product features
- Prior product experience
- Warranty
- Design/appearance
- Service
- Value for the price
- Rebate or sale price

Please detach and mail in the warranty registration within ten days of purchase.

# Commercial Equipment Limited Warranty

PLEASE READ THESE WARRANTY TERMS AND CONDITIONS CAREFULLY BEFORE USING YOUR PRECOR INCORPORATED PRODUCT. BY USING THE EQUIPMENT, YOU ARE CONSENTING TO BE BOUND BY THE FOLLOWING WARRANTY TERMS AND CONDITIONS.

## Limited Warranty.

Precor Incorporated warrants all new Precor products to be free from defects in materials and manufacture for the warranty periods set forth below. The warranty periods commence on the invoice date of the original purchase. This warranty applies only against defects discovered within the warranty period and extends only to the original purchaser of the product. Parts repaired or replaced under the terms of this warranty will be warranted for the remainder of the original warranty period only. To claim under this warranty, the buyer must notify Precor or your authorized Precor dealer within 30 days after the date of discovery of any nonconformity and make the affected product available for inspection by Precor or its service representative. Precor's obligations under this warranty are limited as set forth below.

## Warranty Periods and Coverage.

### Commercial Cardiovascular Products, also known as C-Series Products, (excluding StretchTrainer, Strength Products).

- Seven years frame, five years touch sensor display housing, two years parts, one year labor.
- For treadmills, five years motor fan, three years drive motor.
- For self-powered ellipticals and bikes, one year battery.
- For InSite, one year parts and labor.
- Labor coverage for options as defined below.

### StretchTrainer

Five years frame, two years parts, 90 days upholstery, no labor.

### Strength Products (S3.45 and S3.25 only)

Ten years frame; three years bearings, guide rods, cams, pulleys; one year belts, cables, hand grips, miscellaneous parts; 90 days upholstery; no labor.

### Options / Accessories / Battery-powered or Self-Operated Devices

Many options or accessories have components that are connected internally or mounted inside the electronic console. The following guidelines determine the warranty for these components. If the internal components are installed by the factory or by an authorized dealer as part of the original sale and delivery, they have a warranty that is identical to the warranty of the equipment in which they are connected or mounted. If the internal components are not installed by the factory or by an authorized dealer as part of the original sale and delivery, they have a 90 days parts and labor limited warranty. All components that are not internally connected have a 90 days parts only limited warranty. Satisfactory proof of purchase is required in all cases.

## Conditions and Restrictions.

### This warranty is valid only in accordance with the conditions set forth below:

1. The warranty applies to the Precor product only while
  - a. it remains in the possession of the original purchaser and proof of purchase is demonstrated,
  - b. it has not been subjected to accident, misuse, abuse, improper service, or non-Precor modification.
  - c. claims are made within the warranty period.
2. Certain products are warranted for standard commercial use only (defined as use in non-fee paying clubs or facilities and less than 6 hours daily use. Unapproved use voids the warranty. Current standard commercial products include C936i, C932i, EFX524i, EFX534i.).
3. This warranty does not cover damage or equipment failure caused by electrical wiring not in compliance with electrical codes or Precor owner's manual specifications, or failure to provide reasonable and necessary maintenance as outlined in the owner's manual.
4. Except in Canada, Precor does not pay labor outside the United States.
5. Warranties outside the United States and Canada may vary. Please contact your local Dealer for details.

### This Limited Warranty shall not apply to:

1. Software (PROM) version upgrades.
2. Normal wear and tear, consumables and cosmetic items, including, but not limited to the following: grips, seats, and labels.
3. Repairs performed on Precor equipment missing a serial number or with a serial tag that has been altered or defaced.
4. Service calls to correct installation of the equipment or instruct owners on how to use the equipment.
5. Pickup and delivery involved with repairs.
6. Any labor costs incurred beyond the applicable labor warranty period.

## Complete this portion and keep for your records.

Purchased From: \_\_\_\_\_ Example: Dealer or store name.

Phone Number: \_\_\_\_\_ Example: Dealer or store telephone number.

Product/model: \_\_\_\_\_ Example: EFX534i or C966i

Serial number: \_\_\_\_\_

The serial number is found on the shipping container.

## Disclaimer and Release.

The warranties provided herein are the exclusive warranties given by Precor and supersede any prior, contrary or additional representations, whether oral or written. ANY IMPLIED WARRANTIES, INCLUDING THE WARRANTY OF MERCHANTABILITY OR FITNESS FOR A PARTICULAR PURPOSE THAT APPLY TO ANY PARTS DESCRIBED ABOVE ARE LIMITED IN DURATION TO THE PERIODS OF EXPRESS WARRANTIES GIVEN ABOVE FOR THOSE SAME PARTS. PRECOR HEREBY DISCLAIMS AND EXCLUDES THOSE WARRANTIES THEREAFTER. Some States do not allow limitations on how long an implied warranty lasts, so the above limitation may not apply to you. PRECOR ALSO HEREBY DISCLAIMS AND EXCLUDES ALL OTHER OBLIGATIONS OR LIABILITIES, EXPRESS OR IMPLIED, ARISING BY LAW OR OTHERWISE, WITH RESPECT TO ANY NONCONFORMANCE OR DEFECT IN ANY PRODUCT, INCLUDING BUT NOT LIMITED TO: (A) ANY OBLIGATION, LIABILITY, RIGHT, CLAIM OR REMEDY IN TORT, WHETHER OR NOT ARISING FROM THE NEGLIGENCE OF PRECOR OR ITS SUPPLIERS (WHETHER ACTIVE, PASSIVE OR IMPUTED); AND (B) ANY OBLIGATION, LIABILITY, RIGHT, CLAIM OR REMEDY FOR LOSS OF OR DAMAGE TO ANY EQUIPMENT. This disclaimer and release shall apply even if the express warranty set forth above fails of its essential purpose.

## Exclusive Remedies.

For any product described above that fails to conform to its warranty, Precor will provide, at their option, one of the following: (1) repair; (2) replacement; or (3) refund of the purchase price. Precor Limited Warranty service may be obtained by contacting the authorized dealer from whom you purchased the item. Precor compensates Servicercs for warranty trips within their normal service area to repair commercial equipment at the customer's location. You may be charged a trip charge outside the service area. THESE SHALL BE THE SOLE AND EXCLUSIVE REMEDIES OF THE BUYER FOR ANY BREACH OF WARRANTY.

## EXCLUSION OF CONSEQUENTIAL AND INCIDENTAL DAMAGES.

PRECOR AND/OR ITS SUPPLIERS SHALL HAVE NO OBLIGATION OR LIABILITY, WHETHER ARISING IN CONTRACT (INCLUDING WARRANTY), TORT (INCLUDING ACTIVE, PASSIVE, OR IMPUTED NEGLIGENCE AND STRICT LIABILITY), OR OTHERWISE, FOR DAMAGE TO THE EQUIPMENT, PROPERTY DAMAGE, LOSS OF USE, REVENUE OR PROFIT, COST OF CAPITAL, COST OF SUBSTITUTE EQUIPMENT, ADDITIONAL COSTS INCURRED BY BUYER (BY WAY OF CORRECTION OR OTHERWISE) OR ANY OTHER INCIDENTAL, SPECIAL, INDIRECT, OR CONSEQUENTIAL DAMAGES, WHETHER RESULTING FROM NONDELIVERY OR FROM THE USE, MISUSE OR INABILITY TO USE THE PRODUCT. This exclusion applies even if the above warranty fails of its essential purposes and regardless of whether such damages are sought for breach of warranty, breach of contract, negligence, or strict liability in tort or under any other legal theory. Some states do not allow the exclusion or limitation of incidental or consequential damages, so the above limitation may not apply to you.

This warranty gives you specific legal rights, and you may also have other rights, which vary from state to state.

# C932i Standard Commercial Treadmill

## Product Specifications

Length: 79 in (201 cm)  
Width: 34 in (84 cm)  
Height: 55 in (140 cm)  
Weight: 280 lbs (126 kg)  
Shipping weight: 320 lbs (144 kg)  
Belt: 57 in x 20 in  
(145 cm x 51 cm)  
Motor: Continuous duty 2.75 hp  
Power: 120 VAC (50/60Hz) 15 Amps  
Speed: 0.5 - 11 mph (1 - 18 kph)  
Incline: 0 - 15% grade  
Frame: Powder-coated steel  
Regulatory Approvals: FCC, ETL, CE

## Product Features

QUICKSTART™  
Reversible Deck  
SmartRate®  
Touch-Sensitive Display  
Heart Rate Telemetry (optional purchase)

## Electronic Specifications

**C932i Programs:** 5 Total  
Heart Rate Control \*  
Interval  
Manual  
Random  
Weight Loss \*

## C932i Display Readouts:

Calories  
Distance  
Heart Rate\*  
Incline  
Profile  
Scan  
SmartRate®\*  
Speed  
Time

\* Optional feature — chest strap required.



Precor Incorporated  
20031 142nd Avenue NE  
P.O. Box 7202  
Woodinville, WA USA 98072-4002

Precor, EFX, M, and SmartRate are registered trademarks and CrossRamp and QUICKSTART are trademarks of Precor Incorporated.  
Copyright 2004 Precor Incorporated.  
Specifications subject to change without notice.  
[www.precor.com](http://www.precor.com)

C932i Lit Kit# 45731-108  
OM# 45733-108  
Online OM# 45733-408  
Warranty# 36286-111  
Warranty Registration# 45622-101  
18 February 2005

## NOTICE:

Precor is widely recognized for its innovative, award winning designs of exercise equipment. Precor aggressively seeks U.S. and foreign patents for both the mechanical construction and the visual aspects of its product design. Any party contemplating the use of Precor's product designs is hereby forewarned that Precor considers the unauthorized appropriation of its proprietary rights to be a very serious matter. Precor will vigorously pursue all unauthorized appropriation of its proprietary rights.