

General Safety & Maintenance Manual

Precor Icarian Line
Commercial Strength Equipment



Important Safety Guidelines

To ensure the safe and proper working condition of the equipment, follow these important safety guidelines:

Important: *Do not modify the equipment or any of its parts, or permanently remove any part from the equipment. Do not use accessory attachments that are not recommended by Precor, as such attachments might cause injuries.*

- Precor designs the Icarian line of strength equipment for use in clubs where regular maintenance is performed by qualified technicians.
- Make sure that trainers, club personnel, and maintenance technicians understand how to use the equipment, know important safety guidelines, and can recognize potential problems, such as a worn cable or cracked weld.
- Strength training requires a significant focus by the club and its staff to ensure a safe fitness environment. If possible, the club should provide direct supervision of the fitness equipment at all times by people knowledgeable about the safe operation of the equipment and trained to recognize potential problems.
- If any club personnel witnesses unsafe use of the equipment, the staff member should address the user directly, demonstrate the proper technique, and review the safety rules. *Consider posting a copy of the Safety Information for Users near the equipment in a prominent location.*
- Make sure the equipment is stable and placed on a solid, level surface. The equipment is designed to be safe on a freestanding basis; however, equipment can be bolted to the floor for extra stability. Consult a qualified general contractor for proper fastening methods.
- Make sure that the equipment is installed with enough free space for safe operation. With most equipment, the general rule is to allow about a 4-foot (1.2 meters) circle of space from the user's center. Do not worry if parts of the equipment lie within this circle; the user can still use the equipment safely. For Functional Training equipment, ensure that the operating space is large enough to allow the cables to be fully extended in all allowable directions.
- Check the equipment thoroughly based on the recommended inspection schedules outlined in this manual, including daily, weekly, monthly and annual checks. Check that all fasteners are securely tightened. Cables should be secured at both end connections. Weight stacks should be secure and functioning properly. The handle attachments should be properly connected to the spring clip.
- Place an "out-of-order" sign on the equipment during maintenance. Users should never be allowed to operate the equipment until it has been inspected and works properly.

- If a piece of equipment needs service, keep it out of use until repaired. Place an “out-of-order” sign on the equipment and make sure club personnel know not to allow anyone to use the equipment until it is working properly.
- When working with the weight stacks, do not attempt to free any jammed assemblies alone as this may cause injury. With the help of another person, carefully return the weight stack to the proper position with the top plate resting on the first weight.
- Do not allow the equipment to be used if the top plate or weight stack is pinned in a raised position. With the help of another person, carefully return the machine to the proper position with the top plate resting on the first weight. Inspect the cable to ensure that it is seated in all of the pulleys.
- Whenever a weight can drop and hit a user, such as with an Olympic bench, Precor highly recommends that a helper or spotter be used to ensure a safe workout with the equipment.

Safety Approval

Certain Precor commercial strength equipment is Class S/C certified according to EN957 –1/2 standards. See an authorized Precor dealer for a complete and current listing of certified machines.

Safety Information for Users

Before beginning any fitness program, you should obtain a complete physical examination from your physician.

Il est conseillé de subir un examen médical complet avant d'entreprendre tout programme d'exercice. Si vous avez des étourdissements ou des faiblesses, arrêtez les exercices immédiatement.

When using exercise equipment, you should always take basic precautions, including the following:

- If you do not understand how to operate a piece of equipment, ask someone from the club such as a trainer to demonstrate how to use it and explain any safety guidelines.
- Do not allow children on or near the equipment. Do not leave children unsupervised around the equipment. Teenagers must be supervised when using the equipment.
- Use the equipment only for its intended purpose. Do not use accessory attachments that are not recommended by the manufacturer, as such attachments may cause injuries.
- Wear proper exercise clothing and shoes for your workout; no loose clothing.
- Do not overexert yourself or work to exhaustion. Use reasonable judgment when working with weights. Avoid using excessive weight, which may cause injury.
- If you feel pain or abnormal symptoms, stop exercising immediately and consult your physician.
- Keep head, limbs, fingers, and hair clear of all moving parts while the equipment is in use. Keep hands clear of racking pegs.

- Never drop or insert objects into any opening in the equipment.
- Always check the equipment before using it. If you spot a potential problem, contact someone in the club immediately. Do not use the equipment. Do not attempt to fix a broken or jammed machine.
- Do not use the equipment outdoors.
- Do not drop or slam the weight stack while exercising.
- Be sure the weight pin is completely inserted. Use only the pin provided by the manufacturer. If unsure, contact someone in the club.
- Never pin the weights in an elevated position. Do not use the equipment if the top plate or weight stack is pinned in a raised position. Notify club personnel.

Table of Contents

Important Safety Guidelines	1	Monthly Inspection	16
Safety Approval	2	Inspect Frames and Movement Arms	16
Safety Information for Users	3	Lubricate Pop Pins	17
Before You Begin	5	Check and Lubricate Ratcheting Seat Lever	17
Recommended Tools	5	Inspect All Fasteners	18
Obtaining Service	6	Annual Maintenance	19
Daily Inspection	7	Weight Stack Annual Maintenance	19
Clean Upholstery	7	Inspect and Lubricate Pop Pins	19
Inspect Pads for Wear	7	Recommended Maintenance Checklist	20
Clean and Inspect Frames	7	Limited Warranty.....	21
Inspect Cables and End Connections	8		
Check Warning Labels and Instruction Placards	9		
Weekly Inspection	11		
Condition and Deep Clean Upholstery	11		
Clean and Lubricate Cable Rod Ends	11		
Clean and Lubricate Guide Rods	12		
Inspect Cables, Connections, and Tension	12		
Inspect Cable Handle Attachments	13		
Inspect Pulleys	13		
Inspect Weight Stack and Selector Pin	13		
Inspect and Lubricate Bearings and Bushings	14		
Check Seat Adjustment and Test Pop Pins	15		

Before You Begin

To ensure safe equipment operation, Precor recommends implementing a thorough maintenance program that incorporates regular safety inspections by qualified maintenance technicians as outlined in this manual.

This manual explains how to maintain the Precor Icarian line of commercial strength equipment. It provides information about items that need to be inspected and maintained on a daily, weekly, monthly, and annual basis. You should perform those tasks that are appropriate for the equipment you are maintaining, and skip those tasks that do not apply. To help you, a checklist is located at the back of this manual that you can follow during your maintenance checks to ensure that nothing appropriate is missed and that your inspection process is documented.

This manual covers the general maintenance procedures that you can do in the club. However, if the equipment requires service beyond the maintenance procedures covered in this manual, refer to *Obtaining Service*.

Important: *Always purchase replacement parts and hardware from Precor. These parts are tested and manufactured specifically for the Precor Icarian line of commercial strength equipment. If you use parts not approved by the manufacturer, you could void the Precor Limited Warranty, and may cause injury to users.*

Precor recommends that maintenance technicians thoroughly read and understand the safety guidelines and maintenance procedures covered in this manual.

Note: If the equipment requires assembly, a separate assembly guide will accompany it and will provide instructions. For information on how to use a piece of equipment, refer to the user instruction placard found on the equipment.

Recommended Tools

We recommend that you put together a toolbox with the following tools. This list covers the tools you may need when you inspect and maintain the equipment.

- Complete combination box wrench set from $15/16$ to $1/2$ -inch
- Complete socket set from $15/16$ to $1/2$ -inch
- Hex nut driver: $1/4$ -inch
- Adjustable 12-inch crescent wrench
- Complete hex key set from $3/8$ to $5/64$ -inch
- Hammer
- Straight shank punch: $1/4$ -inch

Obtaining Service

You should not attempt to service the strength equipment, except for the maintenance tasks described in this manual. If any items are missing, contact your dealer. Should you need more information regarding customer support numbers or a list of Precor authorized service centers, visit the Precor website at www.precor.com.

If you have any questions regarding a piece of equipment, you will need its serial number when you contact Precor Customer Support. Precor uses the serial number in order to establish the model and year of the product. You can generally find the serial number underneath the seat support.

Note: If your equipment does not have a seat, look for the serial number along the base frame behind the weight stack. For weight benches and racks, look for the serial number on the underside or rear of the main horizontal (or angled) frame support. If you have trouble locating the serial number on your equipment, contact Precor Customer Support.

For future reference, write the serial and model numbers and date of purchase in the space provided. You may want to list all the Icarian equipment information below for easy reference.

Model #: _____ Serial #: _____

Date purchased: _____

Model #: _____ Serial #: _____

Date purchased: _____

Model #: _____ Serial #: _____

Date purchased: _____

Model #: _____ Serial #: _____

Date purchased: _____

Model #: _____ Serial #: _____

Date purchased: _____

Model #: _____ Serial #: _____

Date purchased: _____

Model #: _____ Serial #: _____

Date purchased: _____

Model #: _____ Serial #: _____

Date purchased: _____

Model #: _____ Serial #: _____

Date purchased: _____

Daily Inspection

You will need to do the following tasks each day to maintain the equipment and keep it operating smoothly and safely. Each of these tasks is covered in this section. You should perform those tasks that are appropriate for the equipment you are maintaining, and skip those tasks that do not apply.

- Inspect cables and end connections for wear.
- Clean and inspect equipment frames.
- Check warning labels and Instruction placards for readability.
- Clean any upholstery on the equipment.
- Inspect pads for wear.

Clean Upholstery

Clean upholstery daily with a mild soap and water solution in a spray bottle. Lightly spray upholstered surfaces and wipe dry with a clean cloth. Cleaning upholstery daily removes surface dirt and perspiration.

Important: To clean the upholstery, do not use cleaning products that have any of these ingredients: solvents, alcohol, ammonia, and petroleum. Use a mild detergent-based cleaner instead.

Inspect Pads for Wear

Inspect pads for cracks in the upholstery, loose staples, and loose mounting bolts. Replace pads as needed (refer to *Obtaining Service* to purchase new pads).

Clean and Inspect Frames

Clean frames daily with a mild soap and water solution in a spray bottle. Wipe the equipment down with a damp cloth and dry completely. Be sure to wipe down both painted parts and chrome parts. Cleaning frames daily removes any grease and dirt.

For chrome parts, use a commercial chrome cleaner to restore and maintain the luster.

As you clean, inspect the frames for cracks, rust, or other damage. Make sure welds are solid and fasteners are properly secured.

Inspect Cables and End Connections

CAUTION: Carefully inspect the cables, pulleys, fasteners, and related hardware regularly. Replace any cable at the first sign of wear using only Precor-supplied replacement parts. With regular use in a club environment, a cable can become worn and may possibly fail. Sudden failure of a worn cable can cause severe injury to a user. Refer to *Obtaining Service* to purchase replacement parts.

Inspect the cables and end connections each day, and replace if damaged. Check for kinks, frayed wires, deterioration of the cable coating, and broken thimbles. Look for signs of wear particularly at crimped ends of the cable and near pulleys. (Refer to Figure 1.)

Important: Cables must be replaced immediately if they are damaged to avoid possible injury to users. All cables should be replaced annually.

Obvious signs of cable damage are as follows:

- Exposed inner wire or broken coating in the area that passes over a pulley
- A “ballooned” cover
- A zigzag or wavy pattern
- Kinks, which may indicate internal damage
- A necked-down cover
- Stretching or cuts in the coating

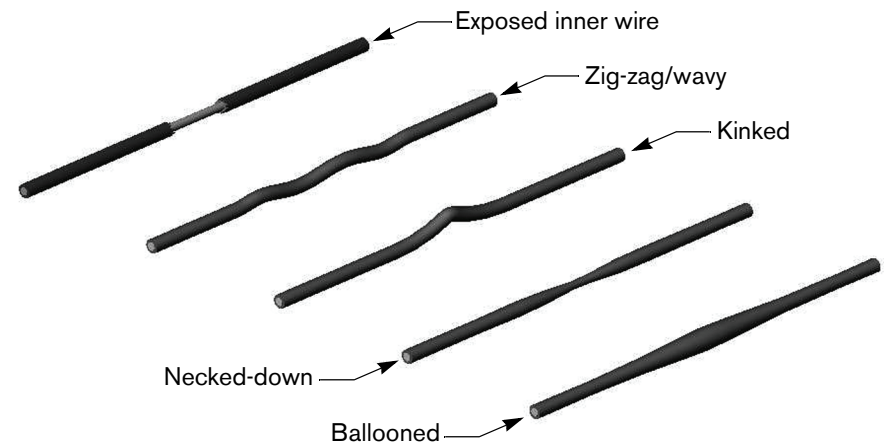

Figure 1: Signs of cable damage

In addition to inspecting the cables and end connections for damage, check the following:

- Ensure that each cable is properly adjusted and tightened at the top of the weight stack.
- Check cable pulleys, end connections, and end fittings. Make sure all connections are tight, adjusting cable tension as necessary.
- Ensure that the cable bolt is threaded a minimum of seven threads into the selector stem, and the locking jam nut is tight. (Refer to Figure 2.)

Cable bolt must be inserted a minimum of 7 threads into the selector stem.

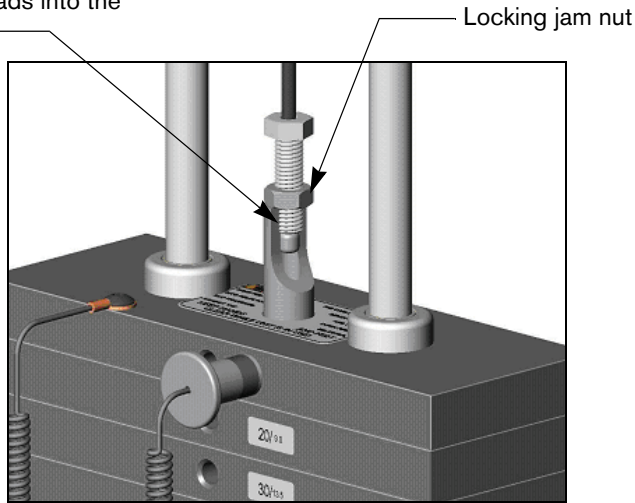

Figure 2: Cable bolt must have a minimum of seven threads into selector stem

Check Warning Labels and Instruction Placards

Inspect warning labels and Instruction placards daily to ensure that all the information can be clearly read. If any portion is not visible, replace that label or placard immediately (refer to *Obtaining Service* to purchase them).

Clean labels and placards as needed with a mild soap and water solution in a spray bottle, and dry thoroughly with a soft cloth.

Figure 3 shows a typical user instruction placard.

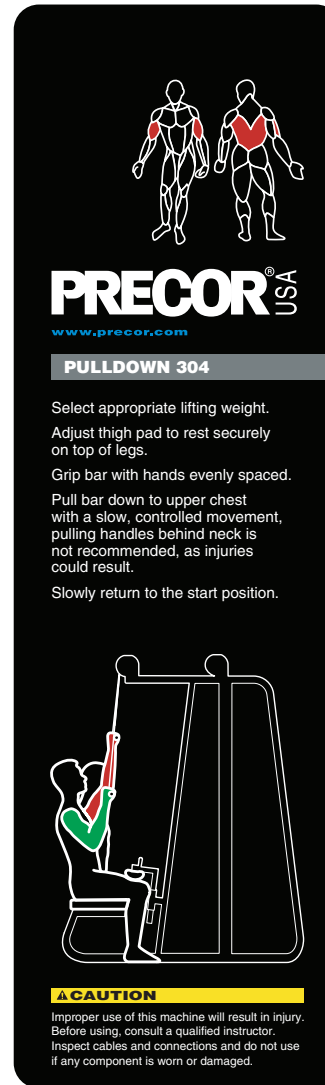

Figure 3: Sample user instruction placard

Precor products come equipped with a number of standard warning labels. The following figures show sample warning labels you may see on the equipment depending on the model:

KEEP HANDS AND FEET CLEAR WHILE MACHINE IS IN USE

Figure 4: This warning label may appear on weight stacks with a pulley mounted at the top

The weight stack cable bolt must be inserted a minimum of seven full turns into the selector stem, and the jam nut tightened down firmly against the selector stem top.

KEEP HANDS AND FEET CLEAR WHILE UNIT IS IN USE!

⚠ WARNING

Figure 5: This warning label may appear on or near weight stacks where a cable bolt is threaded into the selector stem

⚠ WARNING

**SERIOUS INJURY
COULD OCCUR IF
THESE PRECAUTIONS
ARE NOT OBSERVED**

Read all warnings and obtain proper instruction on use of the machine prior to using.

Obtain a medical exam prior to beginning an exercise program.

Keep head, limbs, fingers, and hair clear of all moving parts.

Inspect machine prior to use. Do NOT use if it appears damaged or inoperable.

Do NOT attempt to fix a broken or jammed machine. Notify floor staff.

Use the machine only for the intended use. Obtain instruction and DO NOT modify the machine.

Be certain that weight pin is completely inserted. Use only the pin provided by the manufacturer. If unsure, seek assistance.

Never pin the weights in an elevated position. DO NOT use the machine if found in this condition. Seek assistance from floor staff.

Children must not be allowed near this machine.

Teenagers must be supervised in the use of this machine.

DO NOT REMOVE THIS LABEL.
REPLACE IF DAMAGED.

Figure 6: A version of this warning label appears on the equipment frame

Weekly Inspection

This section covers the tasks you should do each week to maintain the equipment. Choose the appropriate tasks for your equipment, depending on what you are maintaining:

- Condition and deep clean upholstery.
- Clean and lubricate cable rod ends.
- Clean and lubricate guide rods.
- Inspect cables, connections, and tension.
- Inspect cable handle attachments.
- Inspect pulleys.
- Inspect each weight stack and selector pin.
- Inspect and lubricate bearings and bushings.
- Check seat adjustment and test pop pins.

Condition and Deep Clean Upholstery

Condition and deep clean the upholstery weekly with a lanolin-based hand cleaner or upholstery cleaner.

Important: To clean the upholstery, do not use cleaning products that have any of these ingredients: solvents, alcohol, ammonia, and petroleum. Use a mild detergent-based cleaner instead.

Clean and Lubricate Cable Rod Ends

Check cable rod ends to ensure the shoulder bolt is secure. If cable rod ends are noisy, you can lubricate them with a silicone spray lubricant, such as Super Lube®. Spray the lubricant onto the joint where the spherical portion is enclosed in the outer housing (refer to Figure 7). Wipe off any excess lubricant with a rag.

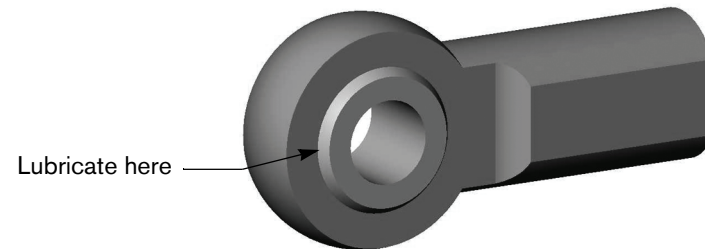

Figure 7: Lubricate cable rod ends with silicone spray lubricant

Important: Do not use petroleum-based lubricants such as WD-40®, Vaseline®, or motor oil.

Clean and Lubricate Guide Rods

Inspect the exposed areas of the guide rods for cleanliness. Using a dry cloth, wipe any buildup of dirt or grease from the rods.

Lubricate the exposed areas of the guide rods by applying a light coat of a silicone spray lubricant. Spray the silicone lubricant on a rag and then wipe the guide rods with the rag. *Be careful with any lubricant spray; it can stain carpet and clothing.*

CAUTION: Do not attempt to lubricate the guide rods when the equipment is in use. Attempting to lubricate between the weight plates without completely disassembling the stack will result in serious injury.

***Important:** Do not use petroleum-based lubricants or motor oil. These lubricants tend to cause a rapid buildup of dirt and hair on the weight plates, which can cause the plates to stick together.*

Note: The CW802 Smith Machine has counter-balance guide rods behind the maintenance shields, which should be cleaned and lubricated weekly.

Inspect Cables, Connections, and Tension

Each week give the cables and connections a thorough inspection and check cable tensions. The following lists the specific things you need to inspect:

- Check the cable termination at the weight stack. For most equipment, the exposed shank can be no more than 1 ¼ inches (32mm); this distance ensures a minimum of 7 turns of the bolt into the selector stem (refer to Figure 2 earlier). Check and adjust the distance accordingly. *Also ensure that the locking jam nut is tight against the selector stem.*
- Check the cable, especially near all pulley wheels and cams.
- Check the cable as it terminates at the cam, which is stationary on most equipment. Inspect the bolt passing through the cam end fitting to be sure the two jam nuts are tightened against each other. Also, check the entire cable routing to verify that there is no interference with any structures.
- Where applicable, ensure that each cable is properly adjusted and tightened at the top of the weight stack.
- Check cable pulleys, end connections, and end fittings. Make sure all connections are tight, adjusting cable tension as necessary.

Inspect Cable Handle Attachments

Check the cable-to-handle attachment area very closely. Refer to Figure 8. Look for frayed cable ends, broken thimbles, bent cables, worn spring clips, worn handles, and any other unusual wear.

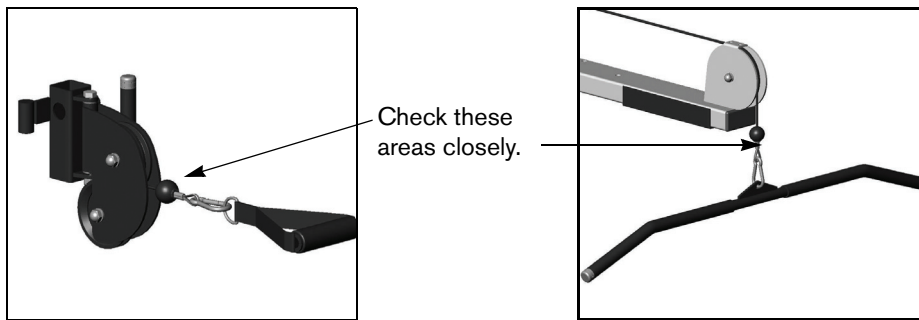

Figure 8: Check connections to handles carefully

Also, check the spring clip gate and make sure it closes properly and engages securely. Refer to Figure 9. Check the spring clip, links, and cable to ensure integrity; replace any spring clip link that does not function properly or shows wear.

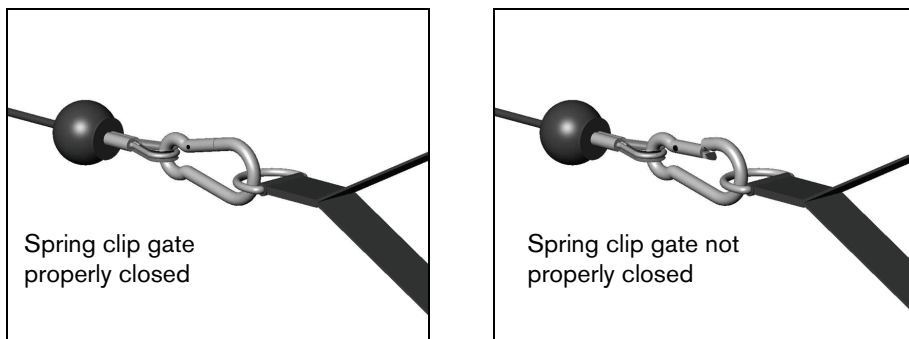

Figure 9: Check spring clip gate to ensure proper closure

Inspect Pulleys

Precor uses precision ball bearing idler pulleys to smoothly guide the cable.

Inspect each pulley for damage, including hairline cracks, chips, or missing sections. Worn surfaces in the pulleys can cause severe damage to the cables and must be replaced at the first sign of wear or damage.

Be certain that the wheels turn freely as the equipment is used. Inspect each pulley for excessive side-to-side play, which indicates worn bearings or loose mounting bolts. If excessive play is discovered, remove the pulley to inspect the bearings, and replace the entire pulley if necessary.

Inspect Weight Stack and Selector Pin

Weight stacks are made of precision machined plates, which stack on top of each other to increase the selected resistance of an exercise. Use only Precor-supplied add-on weights and weight selector pins.

On a weekly basis, inspect weight stacks and selector pins. Wipe each plate with a damp cloth as needed. Inspect all plates for sharp burrs or damage. Wipe dirt and dust off the guide rods.

Make sure the equipment uses only the original Precor selector pin. In addition, make sure the selector pin can be fully inserted and retained in each weight plate.

Inspect and Lubricate Bearings and Bushings

Precor uses only the highest quality bearings and linear motion components, but they must be maintained for a long service life. Each week, do the following to maintain the bearings and bushings on the equipment:

- **Bronze bushings:** Precor recommends using a small amount of silicone spray lubricant to lubricate the bushings. Spray directly onto the shaft, and then move the shaft through its complete range of motion several times. Inspect bushings for excessive wear and damage. *Be careful when using the spray lubricant; it can stain carpet and clothing.* Wipe off any excess lubricant with a rag.
- **Nylon bushings:** Lubricate the nylon bushings on the guide rods by applying a light coat of silicone spray lubricant. Spray the silicone lubricant on a rag and then wipe the rag up and down the shaft.
- **Sealed Bearing Pivot Points:** These locations are protected from the outside environment and require no lubrication. While cleaning the equipment, wipe down the shafts and external bearing surfaces with a rag to prevent the build up of dust and perspiration.

- **Linear Bearings:** Case hardened shafts are used in areas that use linear bearings (refer to Figure 10). The extreme hardness of the shaft is required to prevent the bearing from wearing a groove in the shaft. Inspect each end of the hardened shaft to ensure they are fastened correctly and all bolts are tight.

Wipe down linear rails using a light application of a silicon spray lubricant to remove dust, hair, and dirt. Polish the shaft using fine grade steel wool if surface rust or oxidation is present.

Important: *Do not use petroleum-based lubricants or motor oil.*

If you lubricate the linear rails regularly, then the bearings will function as designed. Otherwise, the linear rails may corrode, which can cause the bearing to become clogged and jammed, leading to the bearing actually gouging the linear rail. Be sure to remove surface rust and oxidation from the hardened rails immediately.

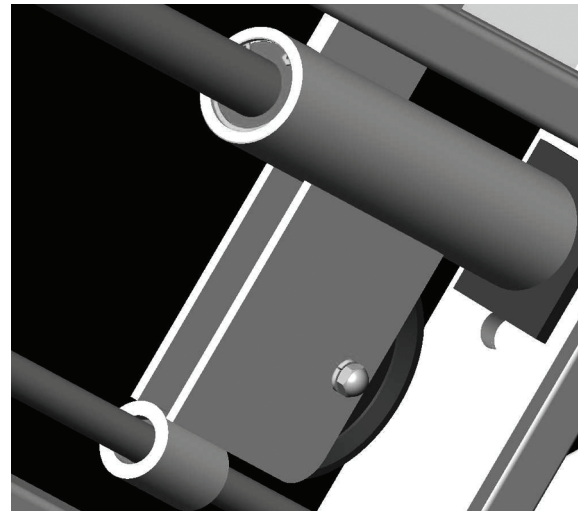

Figure 10: Shows a typical location of a linear bearing in its housing

Check Seat Adjustment and Test Pop Pins

Precor strength equipment has two types of adjustments:

- 2x4-inch or 2x2-inch telescoping sleeve adjustment for most seat assemblies
- 1/2-inch slotted plate adjustments used on most free-weight bench adjustments

Inspect all adjustments for proper fit and function. Inspect plastic sliders for excessive wear or damage.

Adjustments use either a high-tensile pop pin plunger assembly or a ratcheting lever assembly. Inspect and tighten all pop pin caps.

Monthly Inspection

Each month, the following tasks should be performed to maintain the equipment. Choose the appropriate tasks based on what you are maintaining.

- Inspect frames and movement arms.
- Lubricate pop pins.
- Check and lubricate ratcheting seat lever
- Inspect all fasteners.

Inspect Frames and Movement Arms

Inspect frames and movement arms monthly for proper function and integrity. Check for cracks, chipped paint, or rust. Touch up dings and chips in the paint as needed. Replace any component at first signs of wear.

Note: You can order touch-up paint from Precor by calling Customer Support. Refer to *Obtaining Service*.

Inspect frames for cracks particularly at the joints. If any cracks are found, immediately take the equipment out of service, and repair it using a qualified maintenance technician. Refer to *Important Safety Guidelines* and *Obtaining Service*).

To remove surface rust from the frame, rub lightly with a fine wet/dry sand paper or fine steel wool. Finish with Precor's touch-up paint if needed. Maintain paint luster with an application of a mild automotive wax product.

To maintain the powder coated and chrome parts, use a mild detergent-based cleaner for light dirt and grime removal. For removing heavier dirt and grease and for polishing, use a good car polish. For scuffs and marks that are not removed by the above methods, use a soft scrub cleanser. Do not use solvents, lacquer thinner, acetone, or finger nail polish remover. For high wear areas, ABS shields have been provided. Replacement shields are available from Precor.

Lubricate Pop Pins

Pull out the pop pin as far as it goes and apply a small amount of silicone spray lubricant. Wipe off any excess lubricant with a rag. (Refer to Figure 11.)

CAUTION: Pulling out the pop pin may cause the unit to suddenly adjust position. To avoid injury, keep your hands and head away from moving parts.

Test the pop pin for proper function and engagement in each adjustment hole.

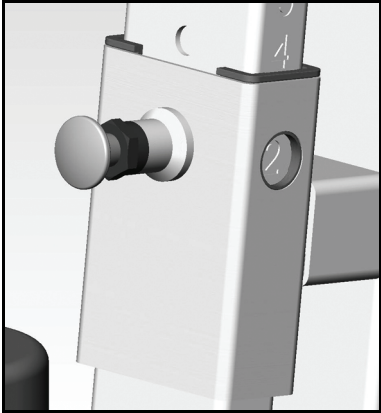

Figure 11: Lubricate the pop pin by pulling it out

Check and Lubricate Ratcheting Seat Lever

Precor designed the ratcheting seat so users can easily move the seat to a comfortable position. After lowering the seat by pressing on the lever to disengage, a user can sit on the seat and pull it up to the desired position. As the seat moves, the ratcheting lever snaps in and out of each hole, making an audible noise.

The ratcheting seat requires little maintenance. However, because seat safety is important to the safety of a workout, you should check the ratcheting seat lever each month to see if it sticks when used. You also want to ensure that the pin fully engages in each adjustment hole.

To test if the seat lever needs lubrication, slightly elevate the seat while pressing and releasing the lever. The lever should snap back out easily. If the lever sticks, lubricate the pivot pin in the lever with silicone spray lubricant. Wipe off any excess lubricant with a rag. (Refer to Figure 12.)

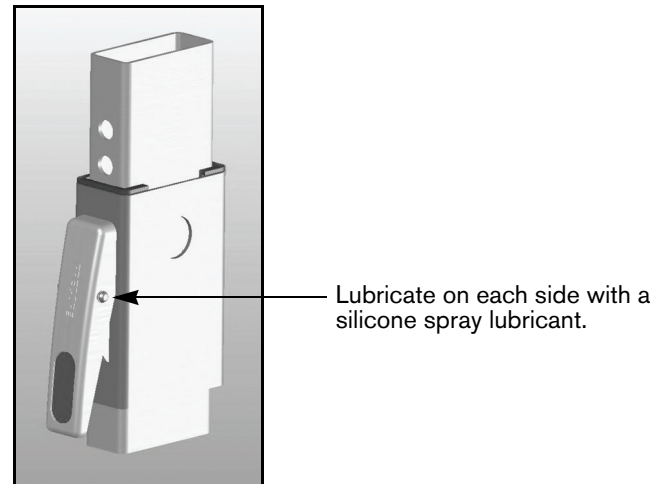

Figure 12: If needed, lubricate the pivot pin on the ratcheting seat lever

If desired, you can detach the seat by removing the retaining pin, allowing you to remove the chrome for cleaning. Removing the seat also allows clear access to the ratcheting lever to test its pivoting action.

Inspect All Fasteners

Precor products are assembled with Grade 5 fasteners or better. With normal use, these fasteners can loosen. Inspect all nuts, bolts, hex key bolts, screws, and other fasteners to ensure they are tight and installed correctly.

Be sure to check fasteners at bolted joints to ensure connection is secure. If the fastener is loose, but in good condition, retighten it. If you are concerned about the integrity of the fastener, remove it, clean the threads, and inspect it for any damage such as cracks, bad threads, corrosion, or rust. Reinstall the fastener if it appears to be in good condition. Otherwise, remove the equipment from service until a new fastener can be installed properly. You can order new fasteners from Customer Support. Refer to *Obtaining Service*.

Annual Maintenance

You should perform these tasks on an annual basis, as appropriate for your equipment.

Weight Stack Annual Maintenance

Once a year, you must disassemble the weight stack and thoroughly clean and inspect it.

- Carefully remove the cable and guide rods from the weight stack. Completely disassemble the weight stack in a well-ventilated area, away from the exercise floor.
- Inspect weight plates and clean them thoroughly. Cracked or broken plates should be replaced immediately (refer to *Obtaining Service* to purchase replacements). Clean each plate individually and inspect guide bushings.
- Inspect the bushings of the top weight plate and replace the plate if excessively worn or broken.
- Clean the selector stem and inspect it for wear and damage.
- Reassemble the weight stack.
- Wipe down the weight stack enclosures (shrouds) with a damp cloth as needed. Inspect all fasteners to ensure the shroud is securely mounted.

Important: *Precor recommends that you replace worn and damaged cables during routine maintenance. All cables should be replaced annually.*

Inspect and Lubricate Pop Pins

Remove the pop pin assembly by loosening the hex head cap.

CAUTION: Pulling out the pop pin may cause the unit to suddenly adjust position. To avoid injury, keep your hands and head away from moving parts.

Inspect the plunger and spring for excessive wear and damage, and replace as required.

Apply a small amount of silicone spray lubricant to the spring and plunger, and then reinstall the entire assembly. Tighten hex head cap. Wipe off any excess lubricant with a rag.

Pop pin plunger assembly shown with telescoping sleeve type adjustment

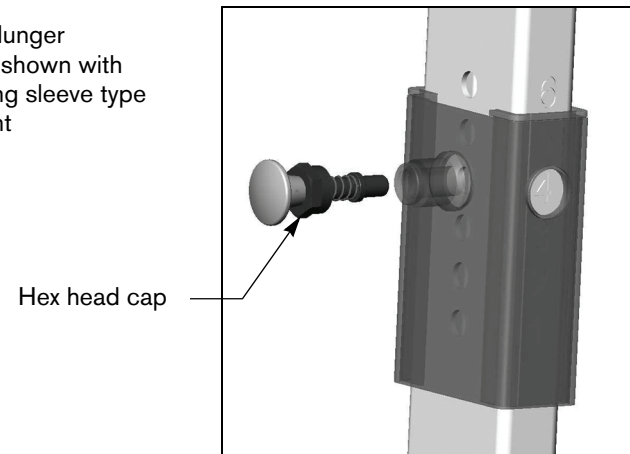

Figure 13: Inspect pop pins (pop pin shown in exploded view for clarity)

Recommended Maintenance Checklist

Please retain for your records.



Maintenance Record the Month of _____
 Brand Name _____
 Model Name & Number _____
 Serial Number _____
 In Service Date _____

Initial box when completed: write N/A if not applicable to the equipment.

Daily Check	1	2	3	4	5	6	7	8	9	10	11	12	13	14	15	16	17	18	19	20	21	22	23	24	25	26	27	28	29	30	31
Clean upholstery																															
Clean & inspect frames																															
Inspect pads for wear																															
Inspect cables & end connections																															
Check labels and placards																															

Weekly Check	7						14						21						28												
Condition & clean upholstery																															
Clean & lubricate cable rod ends																															
Clean & lubricate guide rods																															
Inspect cables/connections/tension																															
Inspect cable handle attachments																															
Inspect pulleys																															
Inspect each weight stack & Pin																															
Inspect & lube bearings & bushings																															
Check seat adjust. and pop pins or ratcheting lever																															

Monthly Check	28																													
Inspect frames & movement arms																														
Inspect & lubricate pop pins or ratcheting lever																														
Check & lubricate ratcheting seat																														
Inspect all fasteners																														

Annual Check	Date:	Initials:
Weight stack maintenance		
Inspect & lubricate pop pins or ratcheting lever		

Maintenance Tips

- Upholstery: Wipe clean using a mild soap and water solution or other appropriate cleaner for vinyl.
- Cable: Replace any cable that shows signs of wear or damage.
- Frames: Wipe clean using a mild soap and water solution.
- Guide rods: Lubricate guide rods with silicone spray lubricant.

Important: It is recommended that cables be changed annually. Only factory provided selector key, lanyard, handle attachment, and handle should be used on selectorized weight stacks. Use of any parts other than those provided by the manufacturer will invalidate the product warranty and may cause injury to users.

Limited Warranty

Precor, Incorporated (PRECOR) will repair or replace any of the following components which are defective as to materials or workmanship for products manufactured and sold after June 1, 1990:

ICARIAN, ABENCH & STRETCH CENTER:*

Lifetime:	Structural Steel Framework
Five Years:	Rotary Bearings, Weight Stacks, Pulleys, Guide Rods, Structural Moving Parts
One Year:	Cable, Linear Bearings, Springs
Ninety Days:	Upholstery, Handgrips, All Other Items Not Listed

JADE PRODUCTS:*

Jade Olympic Plates

Lifetime to original purchaser against breakage of plate.
Paint or coating, 90 days for defects of materials or workmanship.

Jade Olympic Bars

5 Years against defects of materials or workmanship.
Paint or coating, 90 days for defects of material or workmanship.

Jade Dumbbells (Assembled machined painted and rubber coated)

1 Year against defects of materials or workmanship.
Paint, coating or chrome, 90 days for defects of materials or workmanship.

Jade Dumbbells (Solid Steel)

10 Years against defects of materials or workmanship.
Paint, coating or chrome, 90 days for defects of materials or workmanship.

Jade Barbells (Assembled machined painted and rubber coated)

1 Year against defects of materials or workmanship.
Paint, coating or chrome, 90 days for defects of materials or workmanship.

Jade Barbells (Solid Steel)

10 Years against defects of materials or workmanship.
Paint, coating or chrome, 90 days for defects of materials or workmanship.

* All other items not specified are subject to 90 days warranty.

Notwithstanding the above, all warranties provided by PRECOR shall terminate upon transfer of ownership of the equipment by the original owner. PRECOR may require the Customer to affirm that he is the original owner of the equipment before providing warranty services. This warranty does not extend to any components which become defective due to abuse, misuse, or lack of proper maintenance or if the equipment under warranty has been modified or altered in anyway. The Customer seeking repair or replacement of defective equipment must notify PRECOR at the address set forth on the back cover of such defect, admit PRECOR authorized service representatives during normal business hours to effect repairs and pre-pay all defective equipment within thirty (30) days of its receipt of notice of the defect from a Customer or the equipment itself.

THIS WARRANTY IS LIMITED TO REPAIR AND/OR REPLACEMENT OF DEFECTIVE EQUIPMENT. Except to the extent it is precluded from doing so in a particular state or other jurisdiction by applicable law. PRECOR DISCLAIMS ANY AND ALL OTHER WARRANTIES WHETHER EXPRESSED OR IMPLIED, INCLUDING BUT NOT LIMITED TO ANY IMPLIED WARRANTY OR MERCHANTABILITY OR FITNESS FOR A PARTICULAR PURPOSE. Moreover, if any damage or defect is caused by the transport carrier, such claims must be filed with the carrier at the time of delivery. PRECOR DISCLAIMS ANY AND ALL RESPONSIBILITY FOR SUCH DAMAGE OR DEFECT, NO DEALER, EMPLOYEE, SALES REPRESENTATIVE OR AGENT HAS ANY AUTHORITY TO MAKE ANY WARRANTIES OR REPRESENTATIONS CONCERNING PRECOR EQUIPMENT BEYOND THOSE SET FORTH IN THIS WARRANTY AND IN OTHER OFFICIAL PRECOR LITERATURE: AND PRECOR DISCLAIMS ALL RESPONSIBILITY FOR ANY SUCH UNAUTHORIZED WARRANTIES OR REPRESENTATIONS.

An individual purchasing PRECOR equipment in California for personal, family or household purposes has the right to have defective equipment serviced or repaired during the warranty period. The warranty period will be extended for the number of whole days that the equipment is out of the buyer's hands for warranty repairs. If a defect exists within the warranty period, the warranty will not expire until the defect has been fixed. The warranty period will also be extended if the warranty repairs have not been performed due to delays caused by circumstances beyond the control of the buyer, or if the warranty repairs did not remedy the defect and the buyer notifies PRECOR or its authorized dealer or sales representative of the failure of the repairs within sixty (60) days after they were completed. If after a reasonable number of attempts, the defect has not been fixed, the buyer may return the equipment for a replacement or a refund subject, in either case, to deduction of a reasonable charge for usage. This time extension does not affect the protections or remedies the buyer has under other laws. Purchasers of PRECOR strength equipment have the right to bring an action at law or in equity to resolve disputes concerning or to enforce the provisions of this warranty. Some states do not allow the exclusion of limitations of incidental or consequential damages and/or limitation on how long an implied warranty lasts, so the above limitations or exclusions may not apply to all Customers. This warranty gives Customers specific legal rights; Customers may also have other rights which may vary from state to state.

Effective 07 March 2005
P/N CW31973-101

Notes:

Notes:



Precor Incorporated
20031 142nd Ave NE
P.O. Box 7202
Woodinville, WA USA 98072-4002

Precor, Icarian, Jade, and Move Beyond are registered trademarks of Precor Incorporated.

Super Lube is a registered trademark of Synco Chemical Corporation.

WD-40 is a registered trademark of CD-40 Company.

Vaseline is a registered trademark of Unilever.

Copyright 2005 Precor Incorporated.

Specifications subject to change without notice.

www.precor.com

NOTICE:

Precor is widely recognized for its innovative, award winning designs of exercise equipment. Precor aggressively seeks U.S. and foreign patents for both the mechanical construction and the visual aspects of its product design. Any party contemplating the use of Precor product designs is hereby forewarned that Precor considers the unauthorized appropriation of its proprietary rights to be a very serious matter. Precor will vigorously pursue all unauthorized appropriation of its proprietary rights.