

**PRECOR**<sup>USA</sup>  
move beyond<sup>®</sup>

# S3.15/S3.19

Leg Press Option

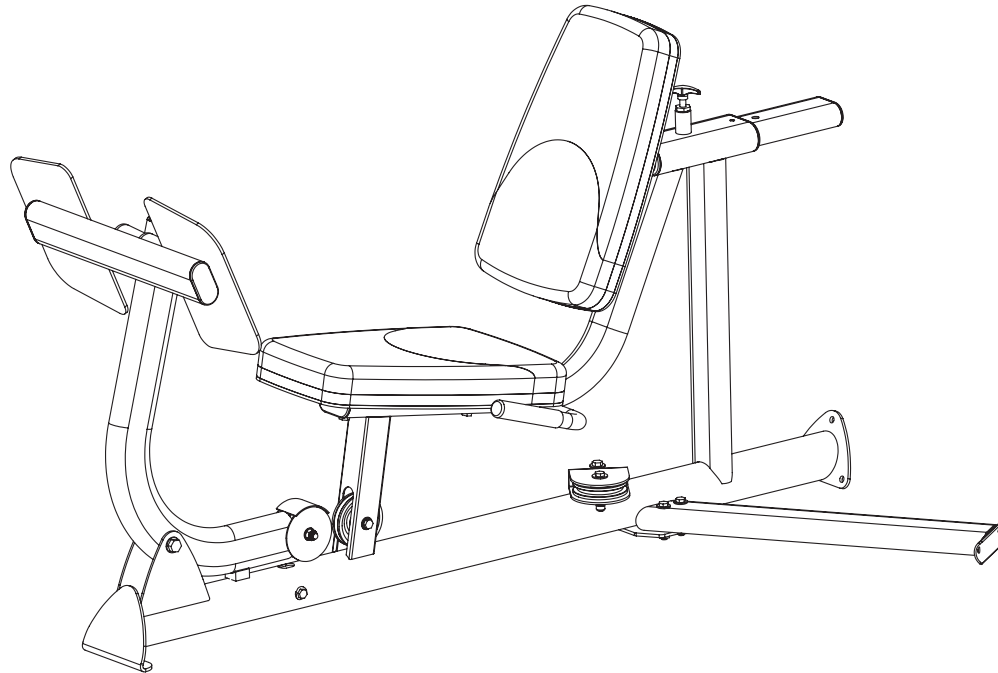

Assembly Instructions

## Important Safety Instructions

Before beginning any fitness program, see your physician for a complete physical examination.

*Il est conseillé de subir un examen médical complet avant d'entreprendre tout programme d'exercice. Si vous avez des étourdissements ou des faiblesses, arrêtez les exercices immédiatement.*

When using exercise equipment, basic precautions should always be taken, including the following:

- Read all instructions before using the Leg Press Option equipment. These instructions are written for your safety and to protect the unit.
- Do not allow children or those unfamiliar with its operation on or near the equipment. Do not leave children unsupervised around the unit.
- Use the equipment only for its intended purpose as described in this manual. Do not use accessory attachments that are not recommended by the manufacturer, as such attachments may cause injuries.
- Wear proper exercise clothing and shoes for your workout and avoid loose clothing. Tie long hair back.
- Use care when getting on or off the unit.
- Do not overexert yourself or work to exhaustion.

- If you feel any pain or abnormal symptoms, stop your workout immediately and consult your physician.
- Never operate the unit when it has been dropped or damaged. Return the equipment to a service center for examination and repair.
- Never drop or insert objects into any opening. Keep hands away from moving parts.
- Always check the unit and its cables before each use. Make sure that all fasteners and cables are secure and in good working condition.
- Do not use outdoors.

### Personal Safety During Assembly

- **It is strongly recommended that a qualified dealer assemble the equipment. Assistance is required.**
- Read each step in the assembly instructions and follow the steps in sequence. Do not skip ahead. If you skip ahead, you may learn later that you have to disassemble components and that you may have damaged the equipment.
- Assemble and operate the Leg Press Option on a solid, level surface. Locate the unit a few feet from walls or furniture to provide easy access.

### Obtaining Service

Do not attempt to service the Leg Press Option yourself except for the maintenance tasks described in this guide. This unit does not contain any user-serviceable parts.

For information about product operation, or service, refer to the Precor web site at [www.precor.com](http://www.precor.com). Should you need more information regarding customer support numbers or a list of Precor authorized service centers, visit the Precor web site at [www.precor.com/cons](http://www.precor.com/cons).

If you call or e-mail Customer Support, have the serial number and part numbers available.

You can find the serial number printed on a label affixed to the base of the Leg Press Option. For future reference, write the serial number in the space provided below.

Serial number: \_\_\_\_\_

## Table of Contents

	<b>Important Safety Instructions .....</b>	<b>2</b>
	Personal Safety During Assembly .....	2
	Obtaining Service .....	2
<b>1</b>	<b>Before You Begin .....</b>	<b>4</b>
	Unpacking the Equipment .....	4
<b>2</b>	<b>Preparations .....</b>	<b>5</b>
	Required Tools .....	5
	Installation Requirements .....	5
	Assembly Tips .....	5
<b>3</b>	<b>Assembly Instructions .....</b>	<b>6</b>
	1. Attach the Leg Press to the Main Unit .....	7
	2. Assemble the Seat Pads and Handle .....	8
	3. Install the Leg Press Arm and Footrest .....	9
	4. Install the Leg Press Cable .....	10
<b>4</b>	<b>Warranty .....</b>	<b>12</b>
	Limited Warranty Statement .....	12
	Warranty Registration Card .....	13
	Specifications .....	Back cover

# 1

## Before You Begin

Thank you for purchasing the Leg Press Option. This option will add a new dimension to your strength-training regimen. For proper installation, please read this guide thoroughly and follow the assembly instructions.

### Unpacking the Equipment

The Leg Press Option is carefully tested and inspected before shipment. Precor Strength ships the unit in several pieces that require assembly. Ask for assistance during the assembly process.

- Review the *Installation Requirements*.
- Carefully unpack the pieces and lay them on the floor near the location where you plan to use the equipment.

If any items are missing, contact the dealer from whom you purchased the unit. For more information, refer to *Obtaining Service*.

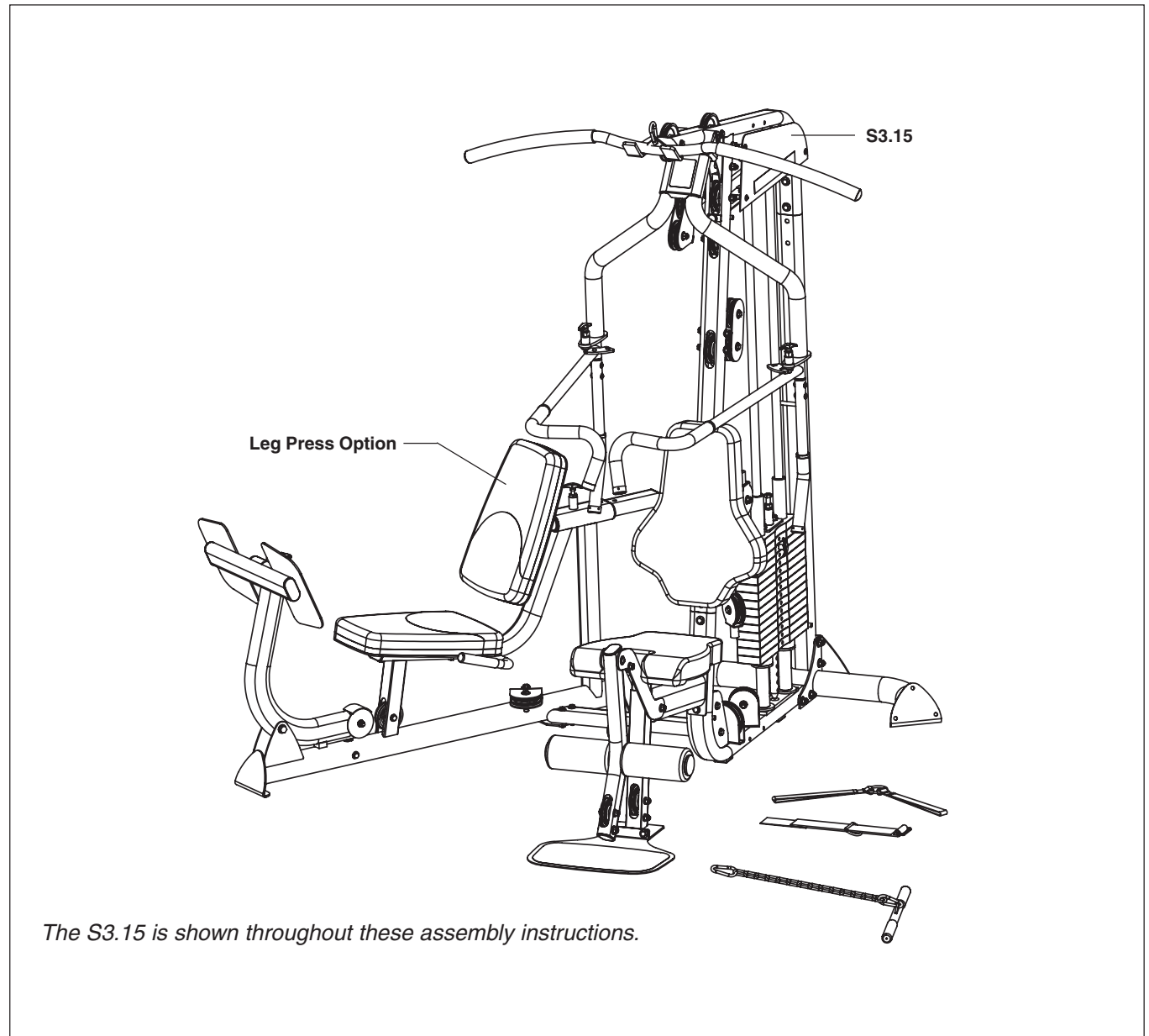

## Before You Begin

# 2

## Preparations

You must review and follow the instructions in this guide. If you do not assemble and use the Leg Press Option according to the following guidelines, you could void the Precor Limited Warranty.

### Required Tools

Tools that you need to obtain before assembling the unit include:

- 1/16-inch socket
- 3/4-inch socket
- 1/16-inch box-end wrench
- 3/4-inch box-end wrench
- Crescent wrench
- Wire tie cutter (cuts plastic tie wraps)
- Utility knife

### Installation Requirements

Follow these installation requirements when assembling the unit:

- **Fill out and mail the warranty registration card.**
- **Set up the Leg Press Option on a solid, flat surface.** A smooth, flat surface under the unit helps keep it level.
- **Provide ample space around the machine.** Open space around the machine allows for easier access.
- **Insert all fasteners in the same direction.** For aesthetic purposes, insert all the fasteners in the same direction unless specified (in text or illustrations) to do otherwise.
- **Leave room for adjustments.** Tighten fasteners (such as screws, nuts, and bolts), so the unit is stable, but leaves room for adjustments. Do not fully tighten fasteners until instructed (in the steps) to do so.

### Assembly Tips

- Fasteners may become loose and fall off during shipment. Inspect the plastic wrap and packaging for loose parts. To alleviate confusion during assembly, reattach the loose fasteners and pulleys found in the packaging.
- A black 6-inch scale with white numbers is provided at the bottom of every assembly instruction page. Use this scale to identify the correct fastener size. The head of a fastener is not used in measuring the length.

- Most fasteners are 3/8-inch unless otherwise noted. To find out the length of a particular fastener, measure its shank (the long, narrow part beneath the head). Refer to the following diagram:

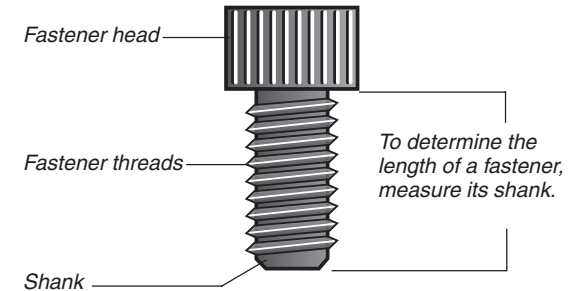

- Zinc fasteners are used with the titanium parts. Black fasteners are used when assembling the stone gray painted surfaces.
- Most fasteners are fitted to the frame or pulley, you will need to disassemble the fasteners before proceeding with each step. Some pieces have extra holes that you will not use. Use only those holes indicated in the instructions and illustrations.
- Read all caution notes on each page before completing that step.
- While you may be able to assemble the Leg Press Option by reading the illustrations only, refer to the text for important safety cautions and notes. The S3.15 is shown throughout the assembly instructions. If you purchased the S31.9, the Leg Press Option assembly is identical.

# 3

## Assembly Instructions

Assembly of the Leg Press Option takes professional installers about ½ hour to complete. If this is the first time you have assembled this type of equipment, plan on significantly more time.

Professional installers are highly recommended!

However, if you acquire the appropriate tools, obtain assistance, and follow the assembly steps sequentially, the process will take time, but is fairly easy.

**CAUTION: Obtain assistance! Do not attempt to assemble the Leg Press Option by yourself. Review the *Installation Requirements* before proceeding with the following steps.**

With so many assembled parts, proper alignment and adjustment is critical. While tightening the fasteners, be sure to leave room for adjustments. Do not fully tighten fasteners until instructed to do so.

**Important:** Be careful to assemble components in the sequence presented in this manual.

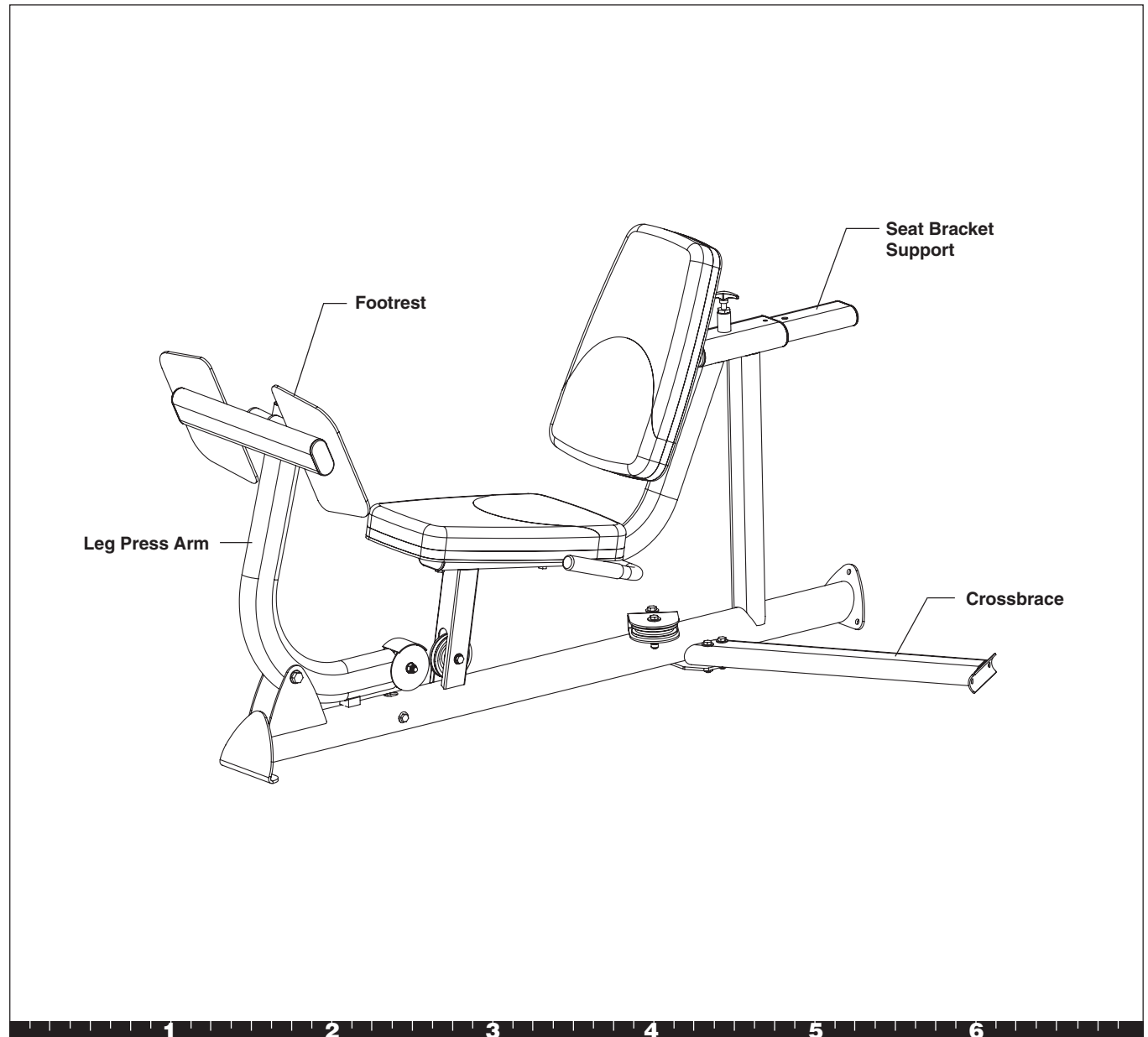

## 1. Attach the Leg Press to the Main Unit

**Important:** Most fasteners are fitted to the frame or pulleys, you may need to disassemble the fasteners before proceeding with each step.

- A. Attach the Leg Press Base to the Rear Crossbar using  
 three 1¼-inch hex head bolts  
 three flat washers  
 three spring washers  
 three locknuts

- B. Position the Crossbrace against the Main Base and place it on top of the Leg Press flange. Attach the Crossbrace to the Leg Press using  
 two 2¼-inch hex head bolts  
 two flat washers

**Note:** If the Multi-Hip is already attached to the S3.15 then, skip step C. You will need to remove two washers and locknuts to attach the Leg Press. Then, replace the washers and locknuts onto the two existing 4¼-inch hex head bolts.

- C. Attach the Crossbrace to the Main Base using  
 two 4¼-inch hex head bolts  
 four radius washers  
 two locknuts

- D. Wrench tighten all fasteners.

**Note:** If you plan to install the S3.15 Multi-Hip Option immediately after you complete the Leg Press Option assembly, place the two washers and locknuts on the fastener ends finger tight so they provide stability, but can easily be removed.

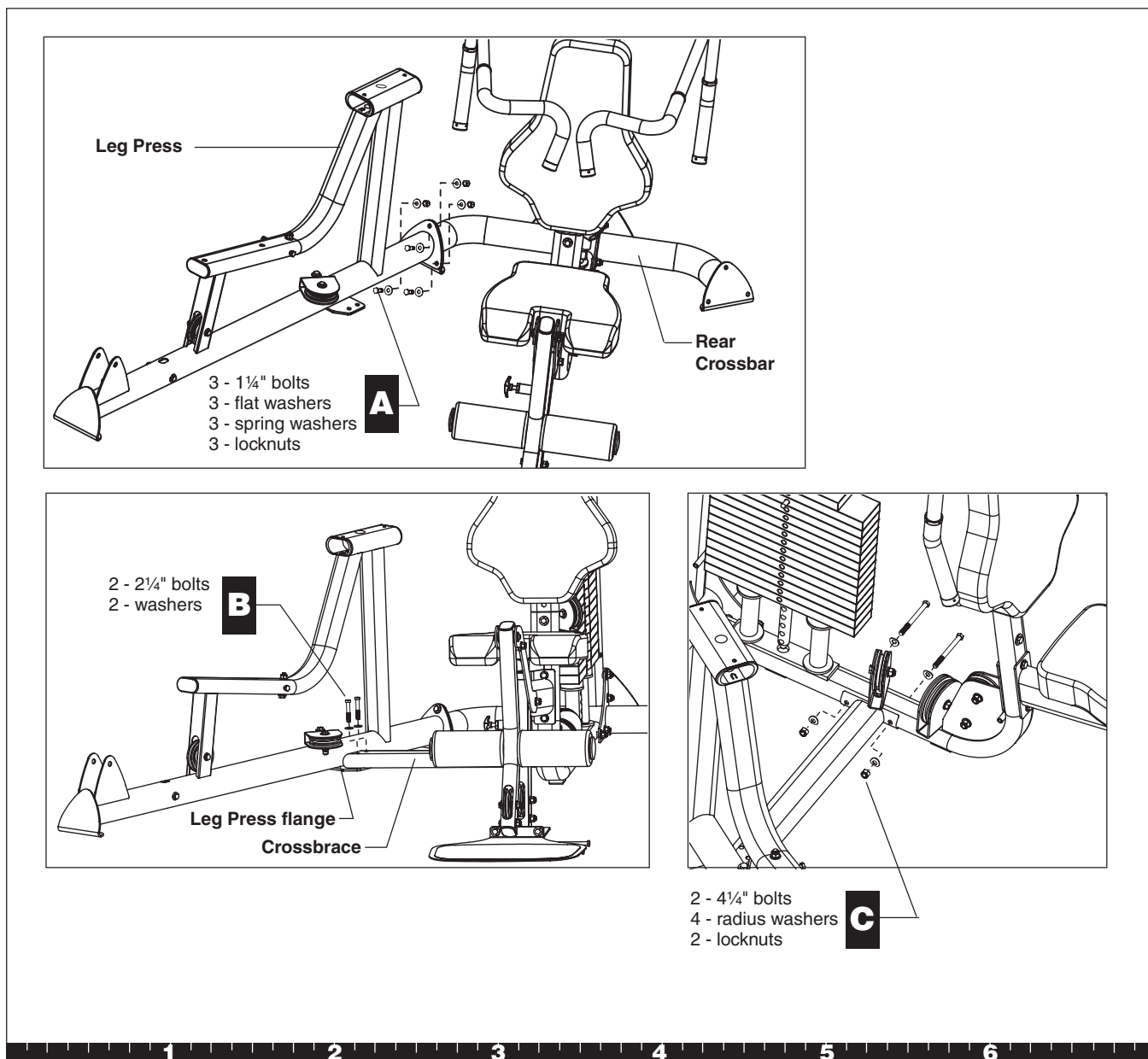

## Step 1. Attach the Leg Press to the Main Unit

## 2. Assemble the Seat Pads and Handle

- A. Thread the T-handle into the Seat Frame and wrench tighten.
- B. Determine which Seat Pad you want to use as the Back Pad. Attach it to the Seat Bracket Support using two 1-inch zinc bolts and two flat zinc washers. Wrench tighten.
- C. Lift the T-handle and slide the Back Pad out of the way to mount the Seat Pad and Handlebar.
- D. Attach the Handlebar to the side of the Seat Frame using one 4¼-inch bolt, two flat washers, and one locknut. Wrench tighten.
- E. Secure the base of the Handlebar using one 2½-inch bolt, two flat washers, and one locknut. Wrench tighten.
- F. Attach the Seat Pad to the Seat Frame using two 2½-inch bolts, two flat washers, and one locknut. Wrench tighten.

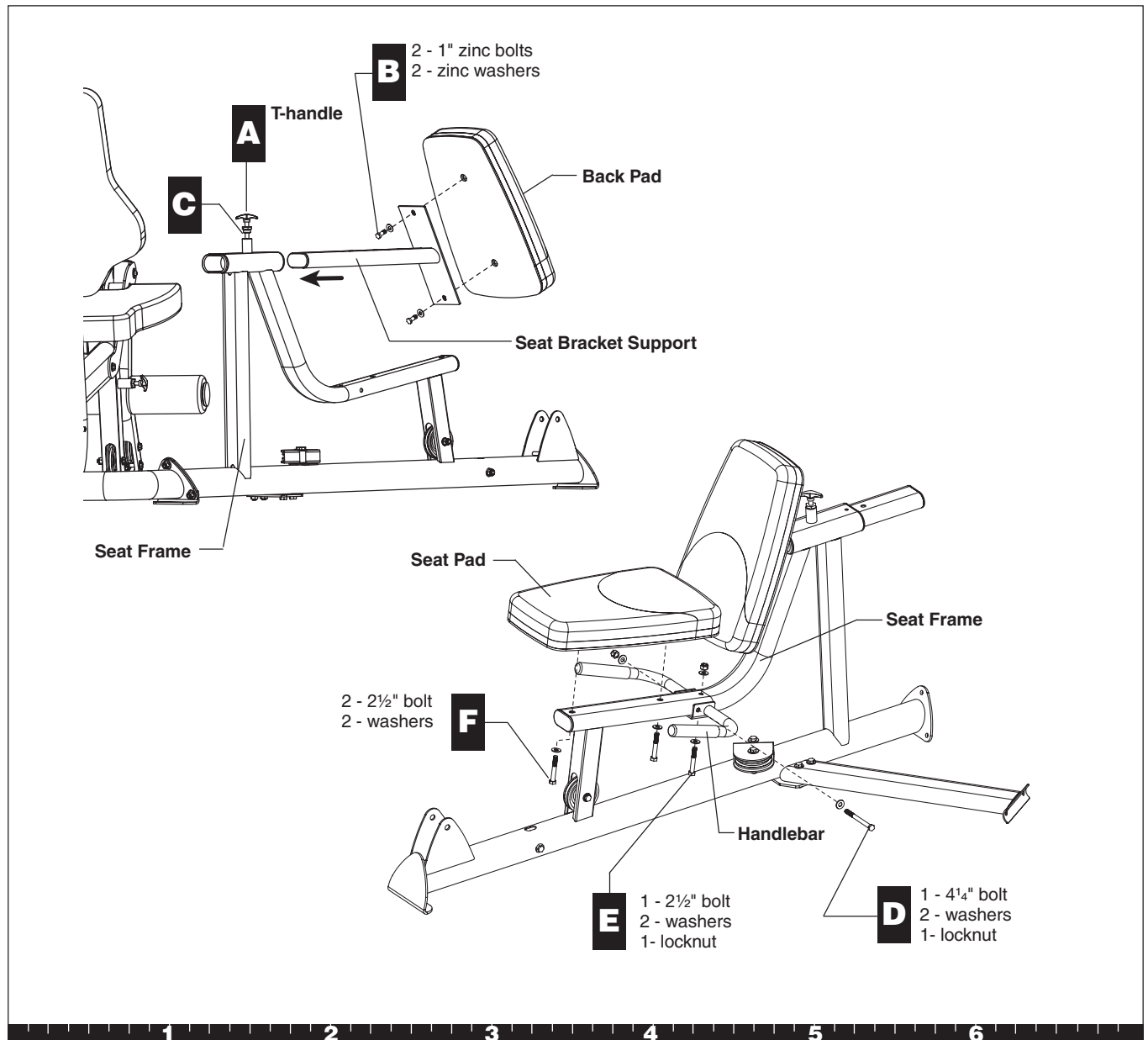

## Step 2. Assemble the Seat Pads and Handle

### 3. Install the Leg Press Arm and Footrest

- A. Attach the Leg Press Arm to the Leg Press using one 1/2-inch x 3 1/2-inch bolt two flat washers one 1/2-inch locknut  
Tighten the fasteners so that the Leg Press Arm is secure and pivots easily.

**CAUTION: The Footrest assembly is heavy and the Leg Press Arm may drop suddenly and cause injury. Ask an adult assistant to hold on to the Leg Press Arm while you attach the Footrest.**

- B. Attach the Footrest to the Leg Press Arm. Have an assistant stabilize the Leg Press Arm while you attach the Footrest using one 1/2-inch by 3 1/2-inch large zinc bolt two 1/2-inch zinc washers one 1/2-inch zinc locknut  
Wrench tighten.

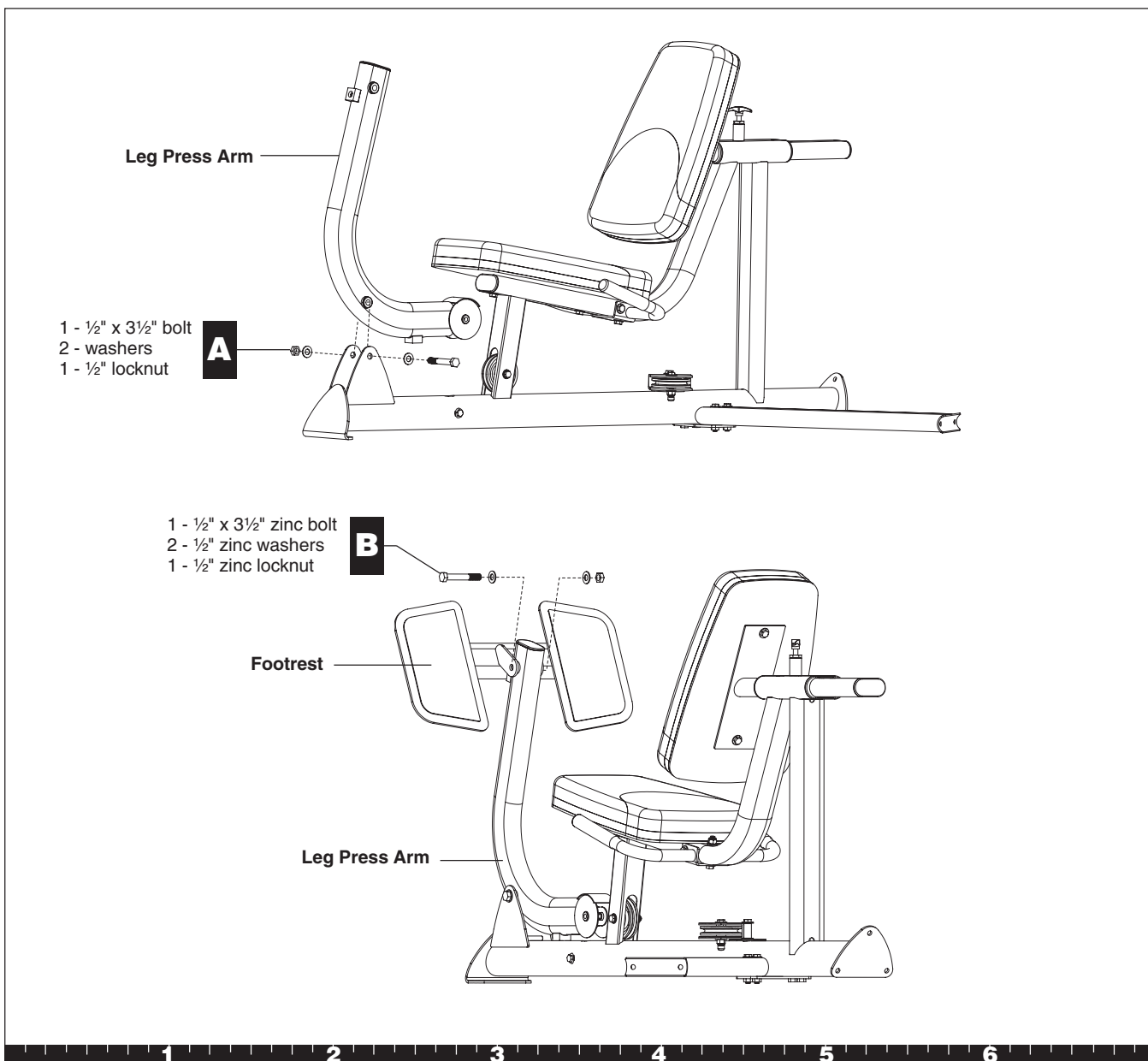

## 4. Install the Leg Press Cable

- A. Lower the Leg Press Arm and rest it on the floor.
- B. Attach the Leg Press Cable 130193 to the base of the Leg Press using
  - one  $\frac{3}{8}$ -inch x  $3\frac{3}{4}$ -inch hex head bolt
  - two washers
  - one  $\frac{1}{2}$ -inch locknut
 Wrench tighten.
- C. Remove one  $3\frac{1}{2}$ -inch pulley on the Seat Base Upright. Feed the cable through the seat base and under the pulley. Reattach the  $3\frac{1}{2}$ -inch pulley using
  - one  $2\frac{3}{4}$ -inch hex head bolt
  - two  $\frac{1}{2}$ -inch shoulder spacers
  - one locknut
 Wrench tighten.
- D. Remove the  $3\frac{1}{2}$ -inch pulley from the adjustable Pulley Bracket. Feed the cable around it and reattach it using
  - one  $2\frac{1}{4}$ -inch zinc hex head bolt
  - two zinc washers
  - one zinc locknut
 Wrench tighten.

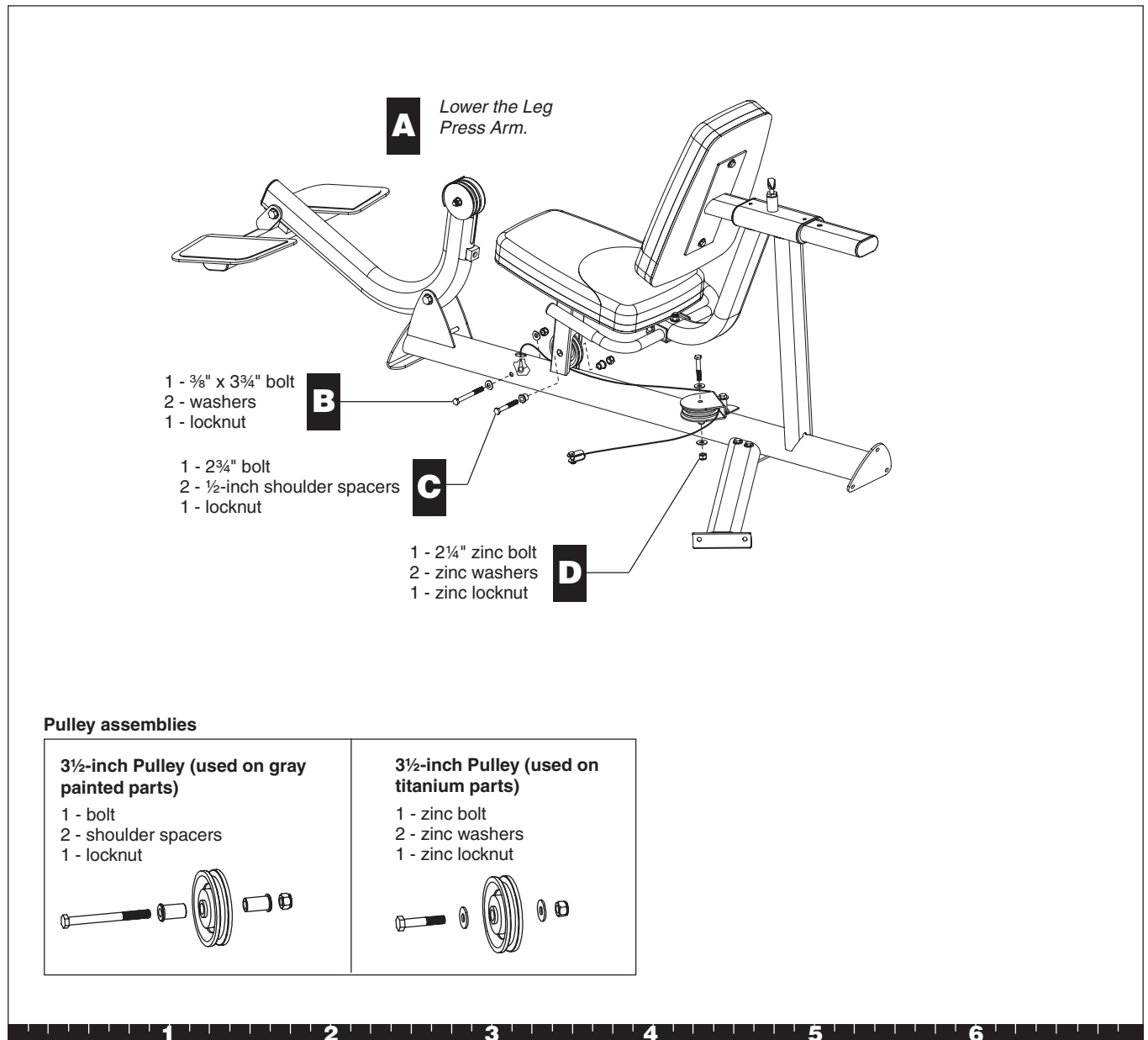

- D. Attach the end of the Leg Press Cable to the S3.15 Cable using  
one 1-inch zinc hex head bolt  
one locknut
- E. Remove the 3½-inch pulley from the Leg Press Arm. Feed the cable around it and reattach it using  
one 2½-inch zinc hex head bolt  
two ½-inch zinc shoulder spacers  
one zinc locknut  
Wrench tighten.

This completes the assembly of the Leg Press Option. Before using the S3.15 or S3.19 with the Leg Press Option, check the cable tension. Refer to *Cable Adjustments and Maintenance* in the *Assembly and Maintenance Guide*.

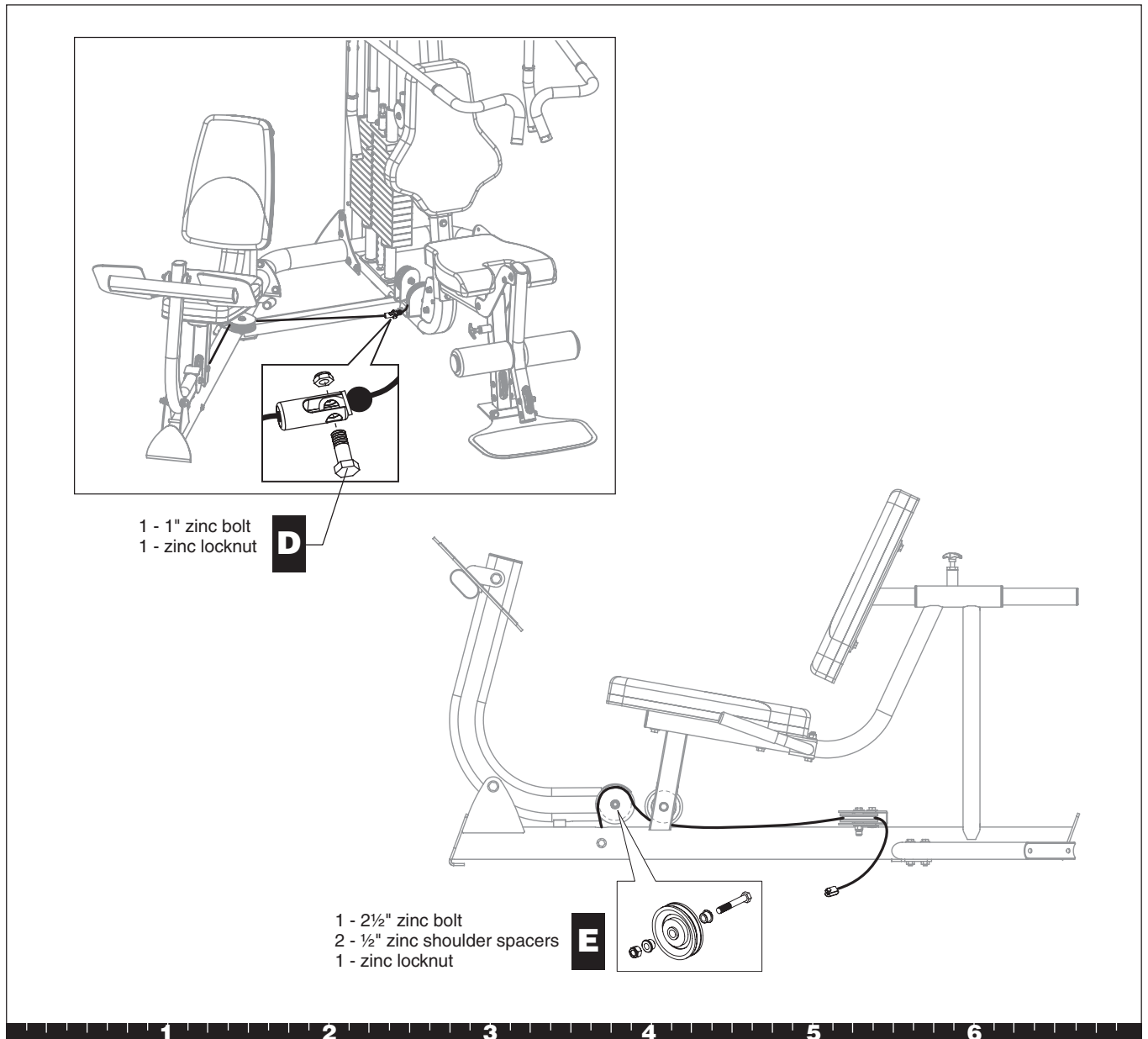

## Step 4. Install the Leg Press Cable, continued

# Precor Residential Equipment Limited Warranty

PLEASE READ THESE WARRANTY TERMS AND CONDITIONS CAREFULLY BEFORE USING YOUR PRECOR INCORPORATED PRODUCT. BY USING THE EQUIPMENT, YOU ARE CONSENTING TO BE BOUND BY THE FOLLOWING WARRANTY TERMS AND CONDITIONS.

## Limited Warranty.

Precor Incorporated warrants all new Precor products to be free from defects in materials and manufacture for the warranty period set forth below. The warranty period commences on the invoice date of original purchase. This warranty applies only against defects discovered within the warranty period and extends only to the original purchaser of the product. Parts repaired or replaced under the terms of this warranty will be warranted for the remainder of the original warranty period only. To make claim under warranty, the buyer must notify Precor or their authorized Precor dealer within 30 days after the date of discovery of any nonconformity and make the affected product available for inspection by Precor or its service representative. Precor's obligations under this warranty are limited and set forth below.

## Warranty Periods and Coverage

All residential products and commercial products used in the home are warranted for the following periods:

- Lifetime frame and welds
- 10 years parts and wear items
- 1 year labor
- Coverage for options and accessories defined below.

## Options / Accessories

Many options or accessories have components that are connected internally or mounted inside the electronic console. The following guidelines determine the warranty for these components. If the internal components are installed by the factory or by an authorized dealer as part of the original sale and delivery, they have a warranty that is identical to the warranty of the equipment in which they are connected or mounted. If the internal components are not installed by the factory or by an authorized dealer as part of the original sale and delivery, they have a 90-day parts and labor limited warranty. All components that are not internally connected have 90-day parts only limited warranty. Satisfactory proof of purchase is required in all cases.

## Conditions and Restrictions

This warranty is valid only in accordance with the conditions set forth below:

1. The warranty applies to the Precor product only while:
  - a. It remains in the possession of the original purchaser and proof of purchase is demonstrated
  - b. It has not been subjected to accident, misuse, abuse, improper service, or non-Precor modifications
  - c. Claims are made within the warranty period
2. This warranty does not cover damage or equipment failure caused by electrical wiring not in compliance with electrical codes or Precor owner's manual specifications, or failure to provide reasonable and necessary maintenance as outlined in the owner's manual.

## Complete this portion and keep for your records.

Purchased From: \_\_\_\_\_ Example: Dealer or store name.  
Phone Number: \_\_\_\_\_ Example: Dealer or store telephone number.  
Product/model: \_\_\_\_\_ Example: M9.31  
Serial number: \_\_\_\_\_ The serial number is found on the shipping container

3. Warranty of all Precor products applies to residential use only and is void when products are used in a nonresidential environment or installed in a country other than where sold.
4. Except in Canada, Precor does not pay labor outside the United States.
5. Warranties outside the United States and Canada may vary. Please contact your local Dealer for details.

## This limited warranty shall not apply to:

1. Software version upgrades
2. Cosmetic items, including, but not limited to the following: grips, seats, and labels.
3. Repairs performed on Precor equipment missing a serial number or with a serial tag that has been altered or defaced.
4. Service calls to correct installation of the equipment or instruct owners on how to use the equipment.
5. Pickup, delivery, or freight charges involved with repairs.
6. Any labor costs incurred beyond the applicable labor warranty period.

## Disclaimer and Release

The warranties provided herein are the exclusive warranties given by Precor and supersede any prior, contrary or additional representations, whether oral or written. ANY IMPLIED WARRANTIES, INCLUDING THE WARRANTY OF MERCHANTABILITY OR FITNESS FOR A PARTICULAR PURPOSE THAT APPLY TO ANY PARTS DESCRIBED ABOVE ARE LIMITED IN DURATION TO THE PERIODS OF EXPRESS WARRANTIES GIVEN ABOVE FOR THOSE SAME PARTS. PRECOR HEREBY DISCLAIMS AND EXCLUDES THOSE WARRANTIES THEREAFTER. Some states do not allow limitation on how long an implied warranty lasts, so the above limitation may not apply to you. PRECOR ALSO HEREBY DISCLAIMS AND EXCLUDES ALL OTHER OBLIGATIONS OR LIABILITIES, EXPRESS OR IMPLIED, ARISING BY LAW OR OTHERWISE, WITH RESPECT TO ANY NONCONFORMANCE OR DEFECT IN ANY PRODUCT, INCLUDING BUT NOT LIMITED TO: (A) ANY OBLIGATION, LIABILITY, RIGHT, CLAIM OR REMEDY IN TORT, WHETHER OR NOT ARISING FROM THE NEGLIGENCE OF PRECOR OR ITS SUPPLIERS (WHETHER ACTIVE, PASSIVE OR IMPUTED); AND (B) ANY OBLIGATION, LIABILITY, RIGHT, CLAIM, OR REMEDY FOR LOSS OF OR DAMAGE TO ANY EQUIPMENT. This disclaimer and release shall apply even if the express warranty set forth above fails of its essential purpose.

## Exclusive Remedies

For any product described above that fails to conform to its warranty, Precor will provide, at their option, one of the following: (1) repair; (2) replacement; or (3) refund of the purchase price. Precor Limited Warranty service may be obtained by contacting the authorized dealer from whom you purchased the item. Precor compensates Servicers for warranty trips within their normal service area to repair equipment at the owner's location. You may be charged a trip charge outside the service area. THESE SHALL BE THE SOLE AND EXCLUSIVE REMEDIES OF THE BUYER FOR ANY BREACH OF WARRANTY.

## Exclusion of Consequential and Incidental Damages

PRECOR AND/OR ITS SUPPLIERS SHALL HAVE NO OBLIGATION OR LIABILITY, WHETHER ARISING IN CONTRACT (INCLUDING WARRANTY), TORT (INCLUDING ACTIVE, PASSIVE, OR IMPUTED NEGLIGENCE AND STRICT LIABILITY), OR OTHERWISE, FOR DAMAGE TO THE EQUIPMENT, PROPERTY DAMAGE, LOSS OF USE, REVENUE OR PROFIT, COST OF CAPITAL, COST OF SUBSTITUTE EQUIPMENT, ADDITIONAL COST INCURRED BY BUYER (BY WAY OF CORRECTION OR OTHERWISE) OR ANY OTHER INCIDENTAL, SPECIAL, INDIRECT, OR CONSEQUENTIAL DAMAGES, WHETHER RESULTING FROM NONDELIVERY OR FROM THE USE, MISUSE OR INABILITY TO USE THE PRODUCT. This exclusion applies even if the above warranty fails of its essential purpose and regardless of whether such damages are sought for breach of warranty, breach of contract, negligence, or strict liability in tort or under any other legal theory. Some states do not allow the exclusion or limitation of incidental or consequential damages, so the above limitation might not apply.

This warranty gives you specific legal rights, and you may also have other rights, which vary state to state.

**Thank You and Welcome to Precor**

**PRECOR**<sup>®</sup>  
USA  
**move beyond**<sup>®</sup>

To allow us to serve you better, please take a few moments to complete and return your warranty registration.

**YOU MAY ALSO REGISTER ONLINE AT**

**[www.precor.com/warranty](http://www.precor.com/warranty)**

If you have questions or need additional information, contact your local dealer or call Precor Customer Support at 800-347-4404.

Fold along dotted line and tape closed before mailing.

RET.

**PRECOR**<sup>®</sup>  
Precor Incorporated  
20031 142nd Avenue NE  
PO Box 7202  
Woodinville, WA 98072-4002

PLACE  
STAMP  
HERE





## S3.15/S3.19 Leg Press Option Specifications

Length: 59 inches (149 cm)

Height: 35 inches (89 cm)

Width: 33 inches (83 cm)

Shipping weight: 115 lb (52 kg)



Precor Incorporated  
20031 142nd Avenue NE  
P.O. Box 7202  
Woodinville, WA USA 98072-4002

Precor is a registered trademark of Precor Incorporated.  
Specifications subject to change without notice.  
Copyright 2006 Precor Incorporated.  
[www.precor.com](http://www.precor.com)

### NOTICE:

Precor is widely recognized for its innovative, award winning designs of exercise equipment. Precor aggressively seeks U.S. and foreign patents for both the mechanical construction and the visual aspects of its product design. Any party contemplating the use of Precor's product designs is hereby forewarned that Precor considers the unauthorized appropriation of its proprietary rights to be a very serious matter. Precor will vigorously pursue all unauthorized appropriation of its proprietary rights.

**Leg Press Option Literature Kit 49455-102**  
Leg Press Assembly Instructions 49454-102  
Warranty Registration 45623-101  
Warranty Card 36287-110  
06 November 2006