

PRECOR^{USA}
move beyond[®]

S3.25

Strength-Training
Fitness Equipment



Assembly and Maintenance Guide

Important Safety Instructions

Before beginning any fitness program, you should obtain a complete physical examination from your physician.

Il est conseillé de subir un examen médical complet avant d'entreprendre tout programme d'exercice. Si vous avez des étourdissements ou des faiblesses, arrêtez les exercices immédiatement.

When using exercise equipment, you should always take basic precautions, including the following:

- Read all instructions before using the S3.25 equipment. These instructions are written to ensure your safety and to protect the unit.
- Do not allow children on or near the equipment.
- Use the equipment only for its intended purpose as described in this guide. Do not use accessory attachments that are not recommended by the manufacturer: such attachments might cause injuries.
- Wear proper exercise clothing and shoes for your workout—no loose clothing.
- Use care when getting on or off the unit.
- Do not overexert yourself or work to exhaustion.
- If you feel any pain or abnormal symptoms, stop your workout immediately and consult your physician.

- Never operate the unit when it has been dropped or damaged. Return the equipment to a service center for examination and repair.
- Never drop or insert objects into any opening in the equipment. Keep hands away from moving parts.
- Always check the unit and its cables before each use. Make sure that all fasteners and cables are secure and in good working condition.
- Do not use the equipment outdoors.

Personal Safety During Assembly

- It is strongly recommended that a qualified dealer assemble the equipment. **Assistance is required.**
- Read each step in the assembly instructions and follow the steps in sequence. Do not skip ahead. If you skip ahead, you may learn later that you have to disassemble components and that you may have damaged the equipment.
- Assemble and operate the S3.25 on a solid, level surface. Locate the unit a few feet from walls or furniture to provide easy access.

The S3.25 is designed for your enjoyment. By following these precautions and using common sense, you will have many safe and pleasurable hours of healthful exercise with your Precor equipment.

Obtaining Service

Do not attempt to service the S3.25 yourself except for the maintenance tasks described in this guide. This unit does not contain any user-serviceable parts.

For information about product operation or service, check out the Precor web site at **www.precor.com** or contact an authorized Precor dealer or a Precor factory-authorized service company. To locate the dealer or service person nearest you, call 1-800-347-4404.

If you call or e-mail Customer Support, have the serial number and part numbers available.

You can find the serial number printed on a label on the back of the two braces on the base of the Main Upright. For future reference, write the serial number in the space below.

Serial number: _____

Table of Contents

	Important Safety Instructions	2
	Personal Safety During Assembly	2
	Obtaining Service	2
1	Before You Begin	5
	Unpacking the Equipment	5
	Optional Equipment	5
2	Preparations for Assembly	6
	Required Tools	6
	Installation Requirements	6
	Assembly Tips	6
3	Assembly Instructions	7
	Open Box 1	8
	1. Attach Rear Upright to Main Upright	9
	2. Attach Chest Press Base	10
	Open Box 2	11
	3. Assemble Leg Curl Seat Extension	12
	4. Attach Rotating Arm and Handles	13
	5. Attach Roller Pads	14
	6. Assemble Leg Curl Seat	15
	Open Box 3	17
	7. Assemble Chest Press Seat	18
	8. Attach Press Arm Assembly	19
	9. Attach Handlebars	20
	10. Assemble Chest Press Seat	21

Open Box 4	22
11. Assemble Weight Stack	23
12. Feed Upper Cable	24
13. Attach Lat Bar Holders	25
14. Feed Cable From Cable Tree	26
15. Attach Leg Curl Cables to Lower Pulley Bracket	29
16. Attach Leg Curl Cables to Seat Upright	30
17. Feed Top Cable 44376-102	31
18. Feed Bottom Cable 44375-103	32
19. Attach Surgical Tubing to Top Beam	33
20. Attach Leg Curl Cables to Cable Tree	34
21. Attach Accessories	35
22. Attach Shrouds	36
4 Adjustments and Maintenance	37
1. Cable Adjustments	37
2. Selector Stem Adjustments	38
Forward Angle Adjustment	38
Backward Angle Adjustment	39
Side-to-Side Vertical Adjustment	40
3. Maintenance	40
Warranty Registration	41
Warranty Card and Specifications	Back cover

4

1

Before You Begin

Thank you for purchasing the S3.25. This unit is part of the Pacific Fitness line of quality strength training machines, which let you target specific muscle groups to achieve better muscle tone and overall body conditioning. To maximize your use of the equipment, please study this guide thoroughly.

Unpacking the Equipment

The S3.25 is carefully tested and inspected before shipment. Pacific Fitness ships the unit in several pieces that require assembly. Ask for assistance during the assembly process.

- Review the *Installation Requirements* found on the next page.
- When instructed to open a box, carefully unpack the pieces and lay them on the floor near the place where you plan to use the equipment.

Be careful to open boxes and assemble components in the sequence presented in this guide.

If any items are missing, contact the dealer from whom you purchased the unit or call 1-800-347-4404 for the dealer nearest you.

Optional Equipment

Optional equipment that you can purchase through your dealer includes the 250-lb Weight Stack and the Leg Press.

Note: If you have also purchased the Leg Press Option and are assembling it simultaneously, specific directions are included to reduce your setup time.



Before You Begin

2

Preparations

CAUTION: To set up this unit, you will need assistance. Do not attempt assembly by yourself.

You must review and follow the instructions in this guide. If you do not assemble and use the S3.25 according to these guidelines, you could void the Pacific Fitness limited warranty (see back cover).

Required Tools

Tools that you must obtain before assembling the unit include:

- 1/16-inch socket wrench
- 3/4-inch socket wrench
- 1/16-inch box-end wrench
- 3/4-inch box-end wrench
- Standard set of metric Allen wrenches
- Two adjustable pliers or crescent wrenches
- Measuring tape
- Wire tie cutter (cuts plastic tie wraps)
- Rubber mallet
- Step stool

Installation Requirements

Follow these installation requirements when assembling the unit:

- **Fill out and mail the limited warranty card.** The warranty card is found on the back cover of this guide.
- **Set up the S3.25 on a solid, flat surface.** A smooth, flat surface under the unit helps keep it level. A level unit has fewer malfunctions.
- **Provide ample space around the machine.** Open space around the machine allows for easier access.
- **Insert all bolts in the same direction.** For aesthetic purposes, insert all the bolts in the same direction unless specified (in text or illustrations) to do otherwise.
- **Leave room for adjustments.** Tighten fasteners such as bolts, nuts, and screws so the unit is stable, but leave room for adjustments. **Do not** fully tighten fasteners until instructed in the assembly steps to do so.

Assembly Tips

- Read all caution notes on each page before completing that step.
- While you may be able to assemble the S3.25 using the illustrations only, important safety notes and other tips are included in the text.

- A 6-inch scale is provided at the bottom of every assembly instruction page. Use this scale to identify the correct size bolts and spacers. The head of a bolt is not used in measuring the length of a bolt.

Note: A few of the bolts used to assemble the S3.25 are longer than 6 inches. You may want to use a measuring tape to accurately identify the correct sizes.

To find out the length of a particular bolt, measure its shank (the long, narrow part beneath the head). Refer to the following diagram:

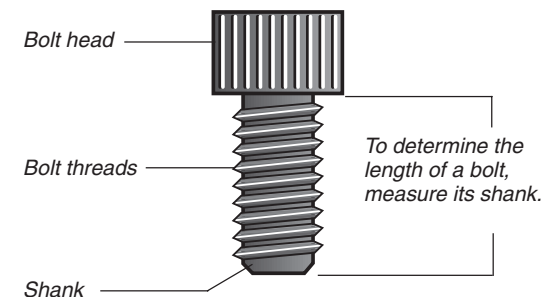

- Some pieces have extra holes that you will not use. Use only those holes indicated in the instructions and illustrations.

3

Assembly Instructions

Assembly of the S3.25 takes professional installers about 1.5 hours to complete. If this is the first time you have assembled this type of equipment, plan on significantly more time.

Professional installers are highly recommended!

However, if you acquire the appropriate tools, obtain assistance, and follow the assembly steps sequentially, the process will take time, but is fairly easy.

CAUTION: Obtain assistance! Do not attempt to assemble the S3.25 by yourself. Review the *Installation Requirements* on page 6 before proceeding with the following steps.

The S3.25 comes in four boxes. (See the diagram at the right.)

Be careful to open boxes and assemble components in the sequence presented in this guide.

Note: With so many assembled parts, proper alignment and adjustment is critical. While tightening the nuts and bolts, be sure to leave room for adjustments. ***Do not fully tighten bolts until instructed to do so.***

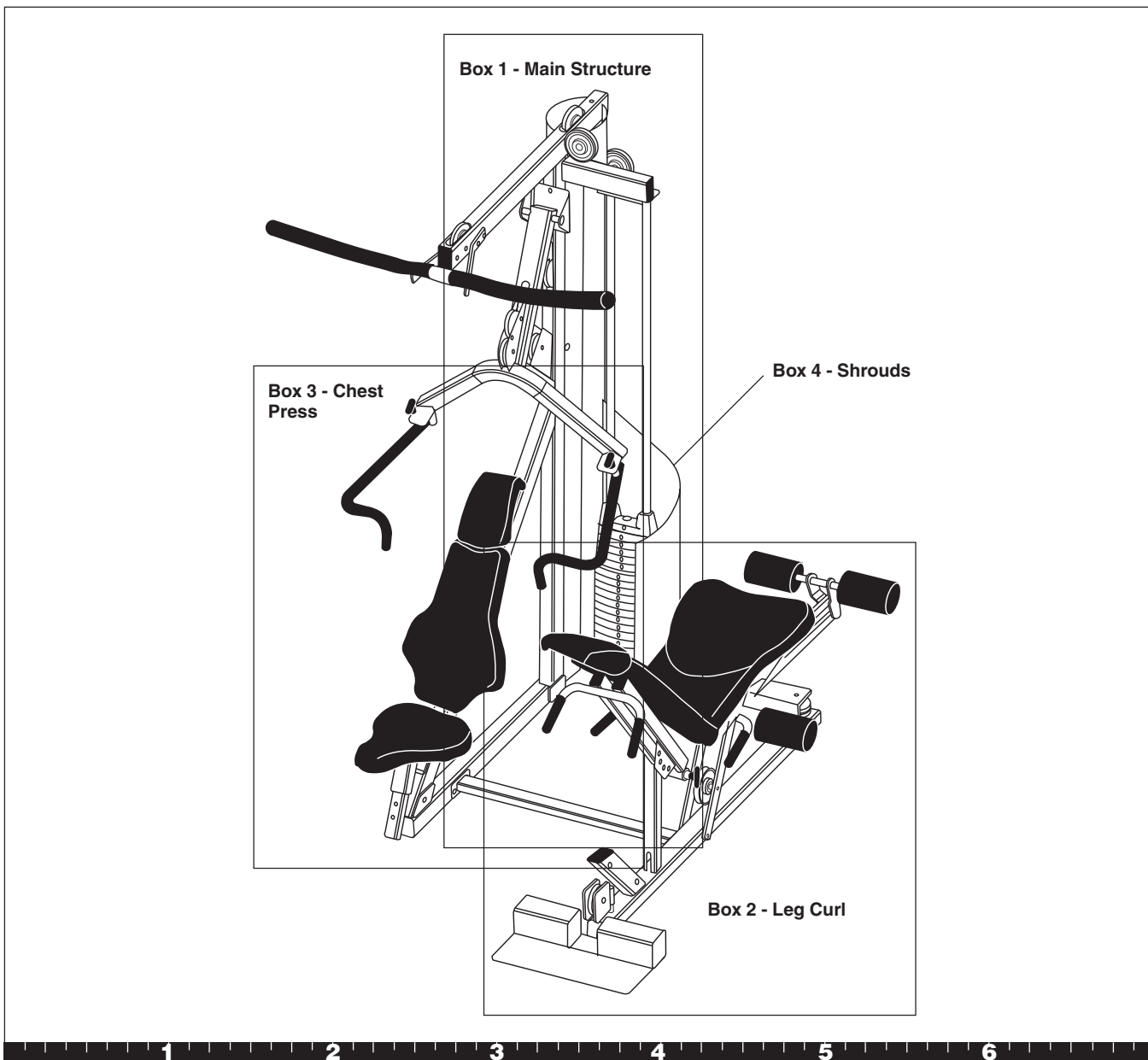

Open Box 1

Use tie cutters to open the box.

The illustration shows how the S3.25 will look after you complete this section.

Note: Some items in these boxes may not be needed until later in the assembly process.

Important: Only use fasteners in bags labeled S3.25. Discard all fasteners in bags labeled S3.45.

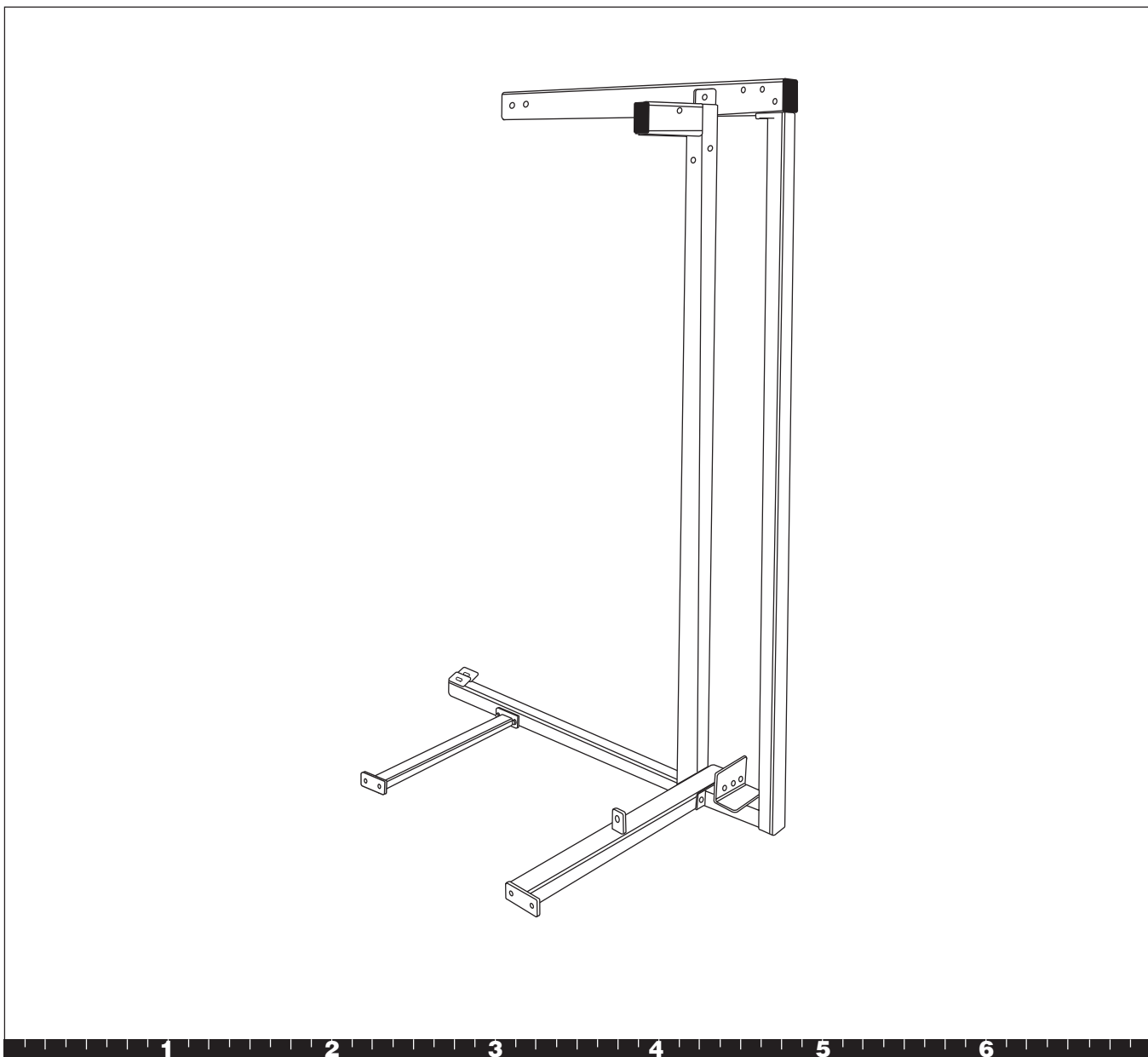

1. Attach Rear Upright to Main Upright

Begin the assembly by placing the Rear Upright and Main Upright on the floor.

- A. Attach the Rear Upright through the Main Upright Base to the Main Upright using two 3¼-inch bolts, four washers, two locknuts. Finger tighten.
- B. Attach the Top Beam to the Rear Upright using one 4-inch bolt, two washers, one locknut. Finger tighten.
- C. Attach the Top Beam to the Main Upright using one 3-inch bolt, two washers, one locknut. Finger tighten.
- D. With someone helping you, lift the structure into position. Place the structure where you intend to keep it permanently.

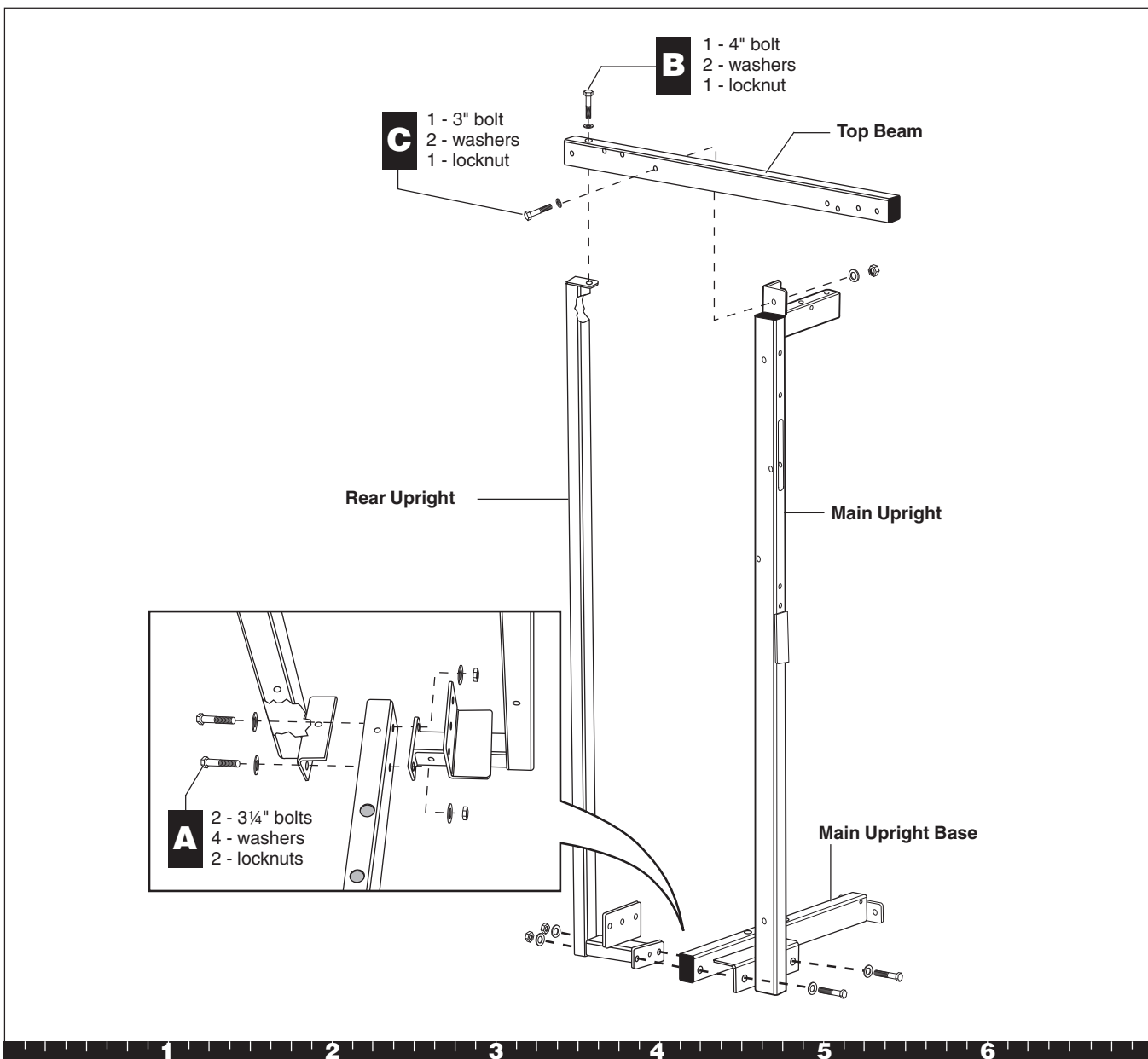

Step 1. Attach Rear Upright to Main Upright

2. Attach Chest Press Base

- A. Attach the Chest Press Base to the Main Upright using
 - one 3¼-inch bolt
 - two washers
 - one locknutFinger tighten.
- B. Attach the Floor Base to the Chest Press Base using
 - two 3-inch bolts
 - four washers
 - two locknutsFinger tighten.

If any parts remain, set them to the side for future steps.

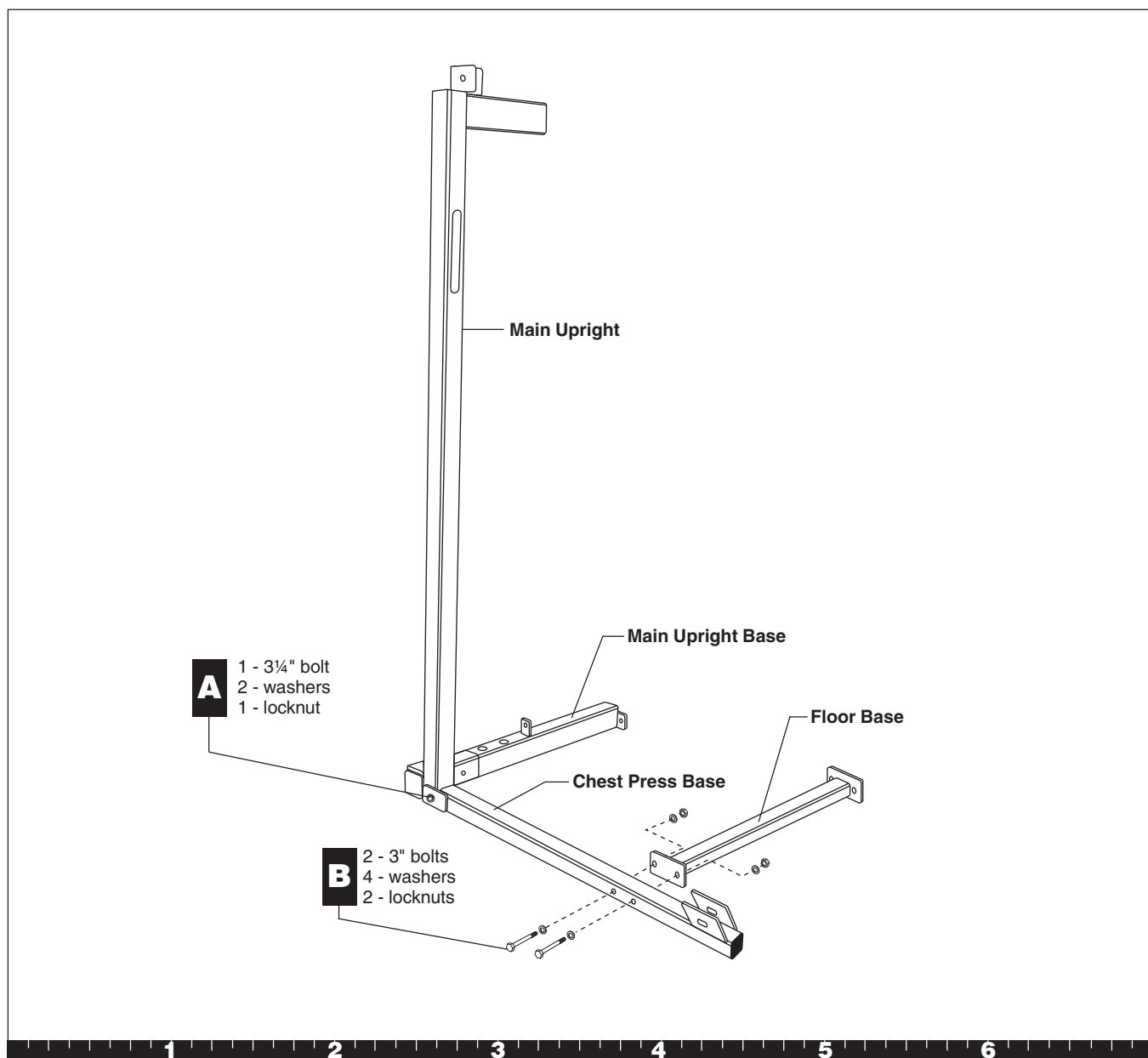

Step 2. Attach Chest Press Base

Open Box 2

Use tie cutters to open the box.

The illustration shows how the S3.25 will look after you complete this section.

Note: Some items in these boxes may not be needed until later in the assembly process.



Open Box 2

3. Assemble Leg Curl Seat Extension

- A. Use a flathead screwdriver to remove the black end cap on the Leg Curl Seat Upright.
- B. Detach the bolts at the bottom of the Upright Flats.
- C. Insert the Leg Curl Seat Extension into the Leg Curl Seat Upright, using a mallet, if necessary. Cover the end cap with a piece of scrap wood to protect the end cap from damage.
- D. Attach the Leg Curl Seat Extension, Leg Curl Seat Upright, and Floor Brace using four $\frac{3}{4}$ -inch bolts four washers Finger tighten.
- E. Reattach the Upright Flats using its bolt, washers, and locknut. Finger tighten.
- F. Attach the Seat Extension to the Main Upright Base using two 4-inch bolts four washers two locknuts Finger tighten.
- G. Attach the Calf Block to the Seat Upright using one $4\frac{1}{4}$ -inch bolt two washers one locknut
- H. Wrench tighten all bolts from this step.

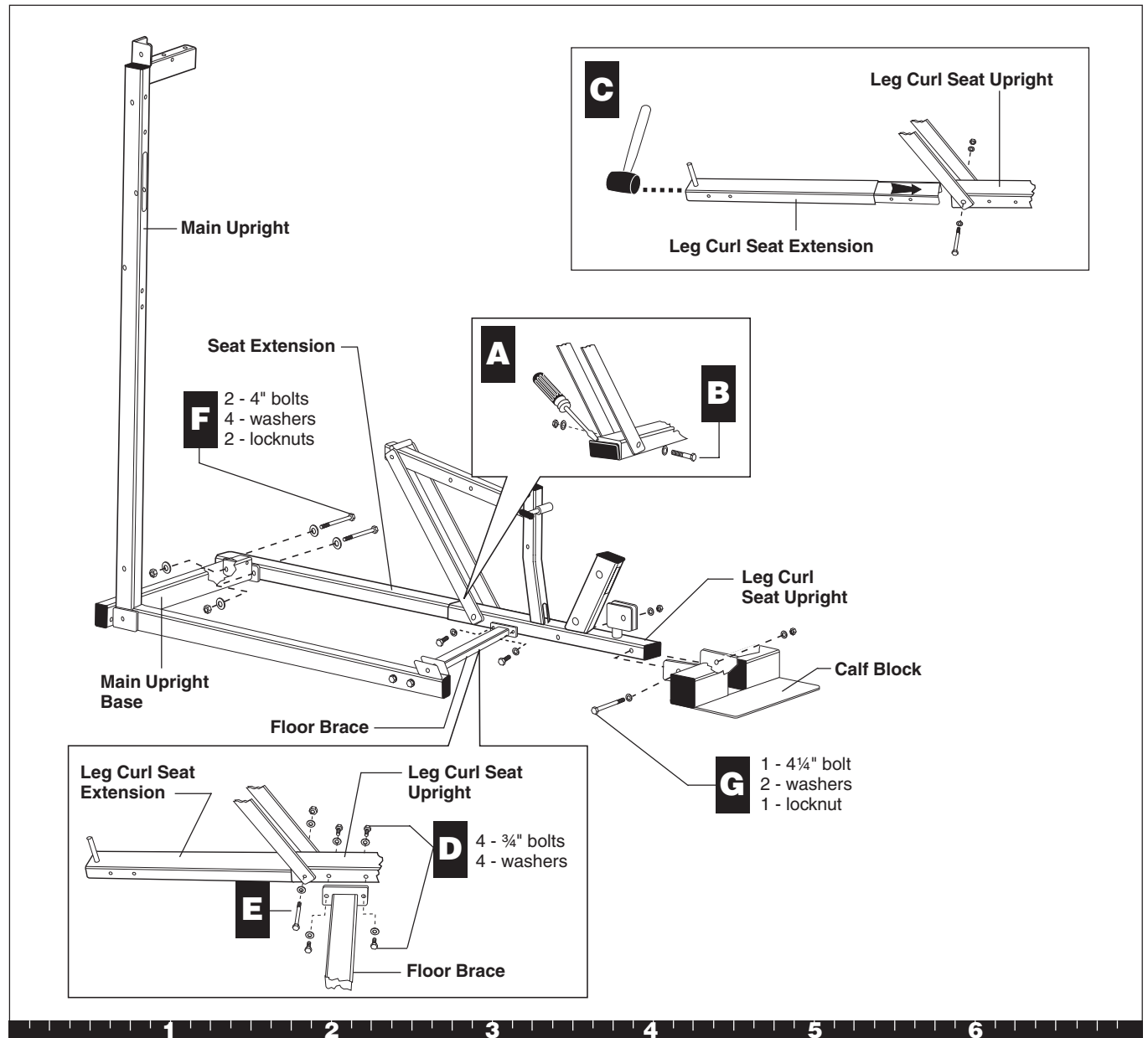

Step 3. Assemble Leg Curl Seat Extension

4. Attach Rotating Arm and Handles

- A. Attach the Rotating Arm to the Upright Flats using two 3/4-inch buttonhead bolts. Tighten with 6-mm Allen wrench.
- B. Attach the Handles to the Seat Upright using two 3/4-inch bolts, four washers, and two locknuts. Wrench tighten.

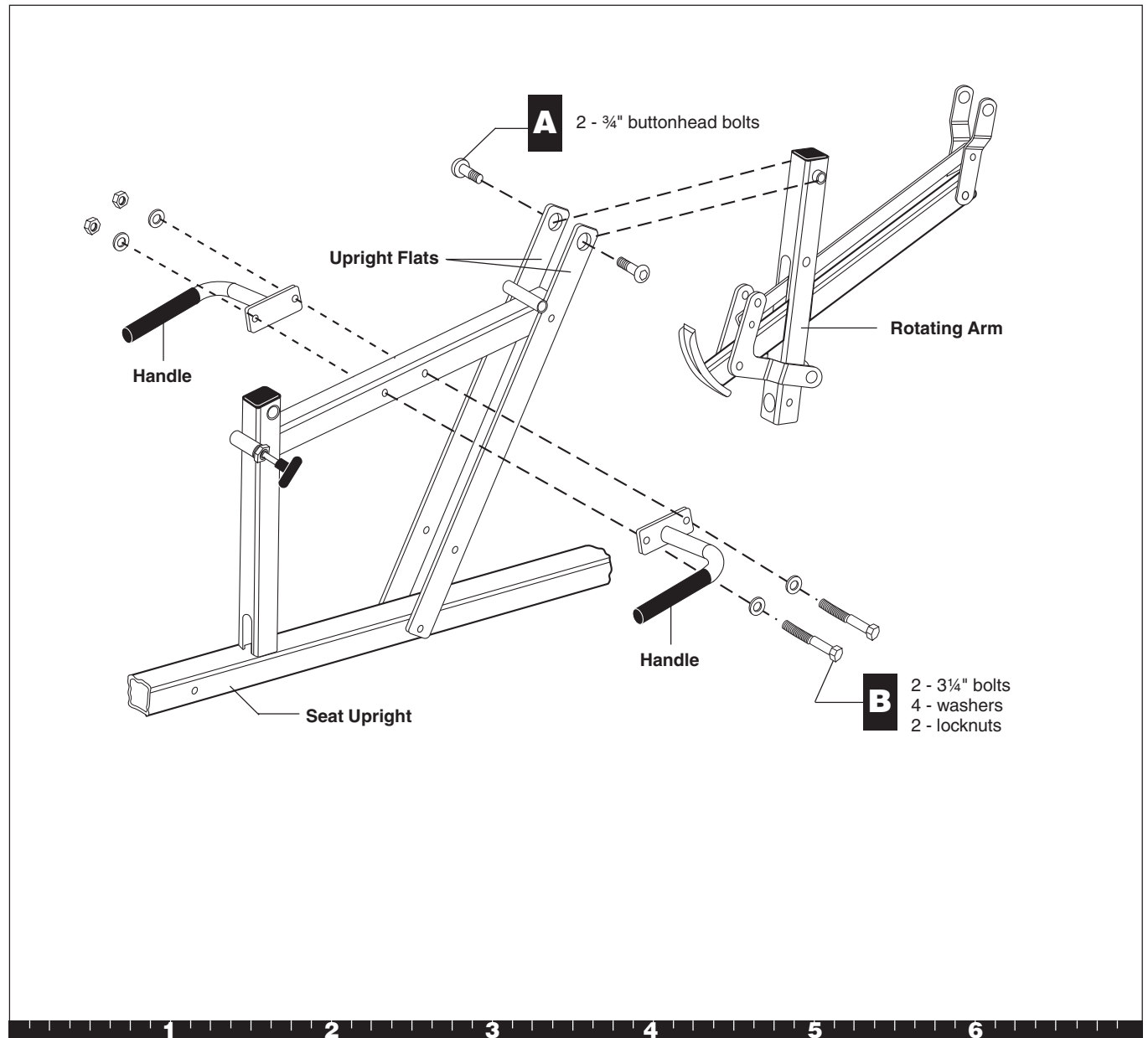

Step 4. Attach Rotating Arm and Handles

5. Attach Roller Pads

- A. Insert the Leg Curl Roller Pad Rod.
- B. Slide the Leg Curl Roller Pads on the Rod. Center the Pads on the Rod. Insert End Caps into the end of the Rod.
- C. Secure the Rod in place from below using two hex set screws.
- D. Repeat steps A through C for the Leg Extension Roller.

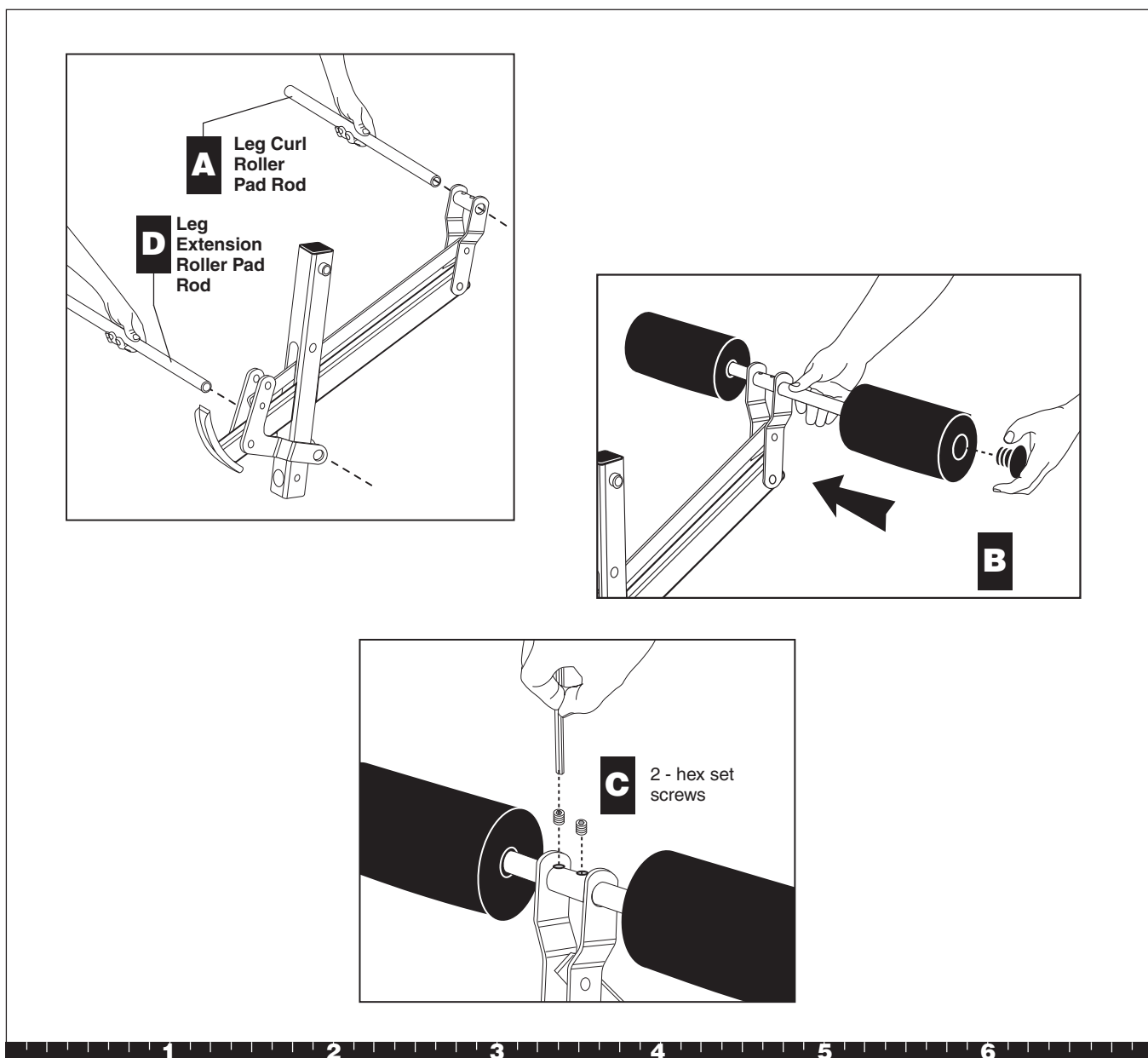

Step 5. Attach Roller Pads

6. Assemble Leg Curl Seat

- A. Attach the Backpad Support Tubes to the Seat Upright using
one 5½-inch bolt
two ½-inch washers
one ½-inch locknut

Note: The tube with the Selector Pivot Flat is nearest the Weight Stack. Also, the hole in the other support tube is positioned closest to the Backpad Pop Pin, as shown.

Wrench tighten, and then loosen until the support tube can fall freely without wobbling.

CAUTION: Keep your hands clear to avoid injury when the support tube falls.

- B. Align the Selector Pivot Flat with the Backpad Pop Pin.
C. Attach the Seat Pad to the Seat Upright using
one 7-inch bolt
one ½-inch locknut
Finger tighten.

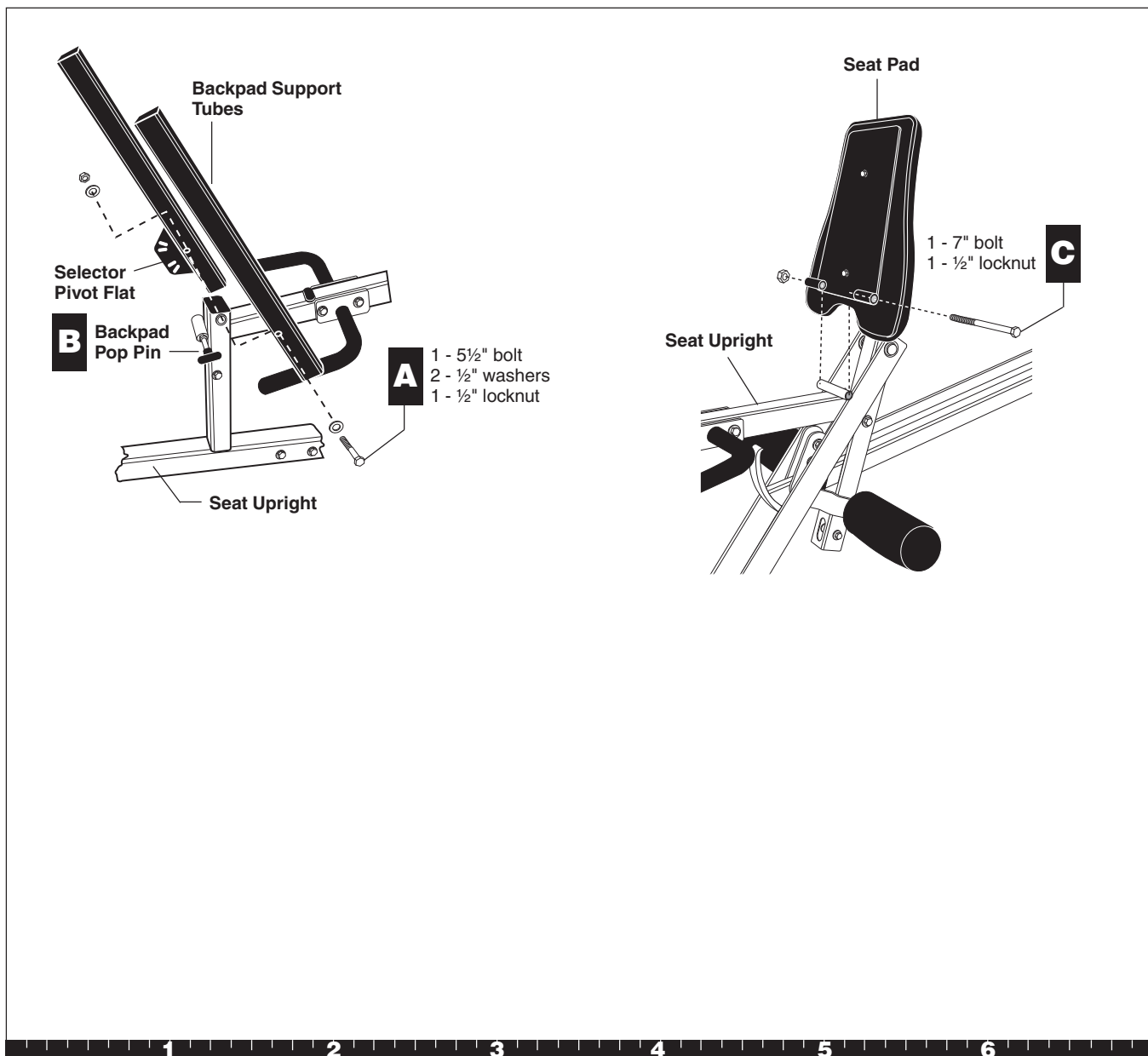

Step 6. Assemble Leg Curl Seat

- D. Attach the lower section of the Backpad to the lower hole of the right Backpad Support Tube using two 3-inch bolt two washers
Finger tighten.
 - E. Attach the Leg Curl Handle to the holes at the top of the Backpad Support Tubes using two 1-inch bolts two washers
 - F. Attach the Backpad Support Tubes to the top of the Backpad using two 3-inch bolts two washers
 - G. Attach the top portion of the Leg Curl Handle to the holes at the top and bottom of the Headrest using two 1¼-inch bolts two washers
- Note:** The Handles should point down when fastened.
- H. Wrench tighten all bolts from this step.
- If any parts remain, set off to the side for future steps.

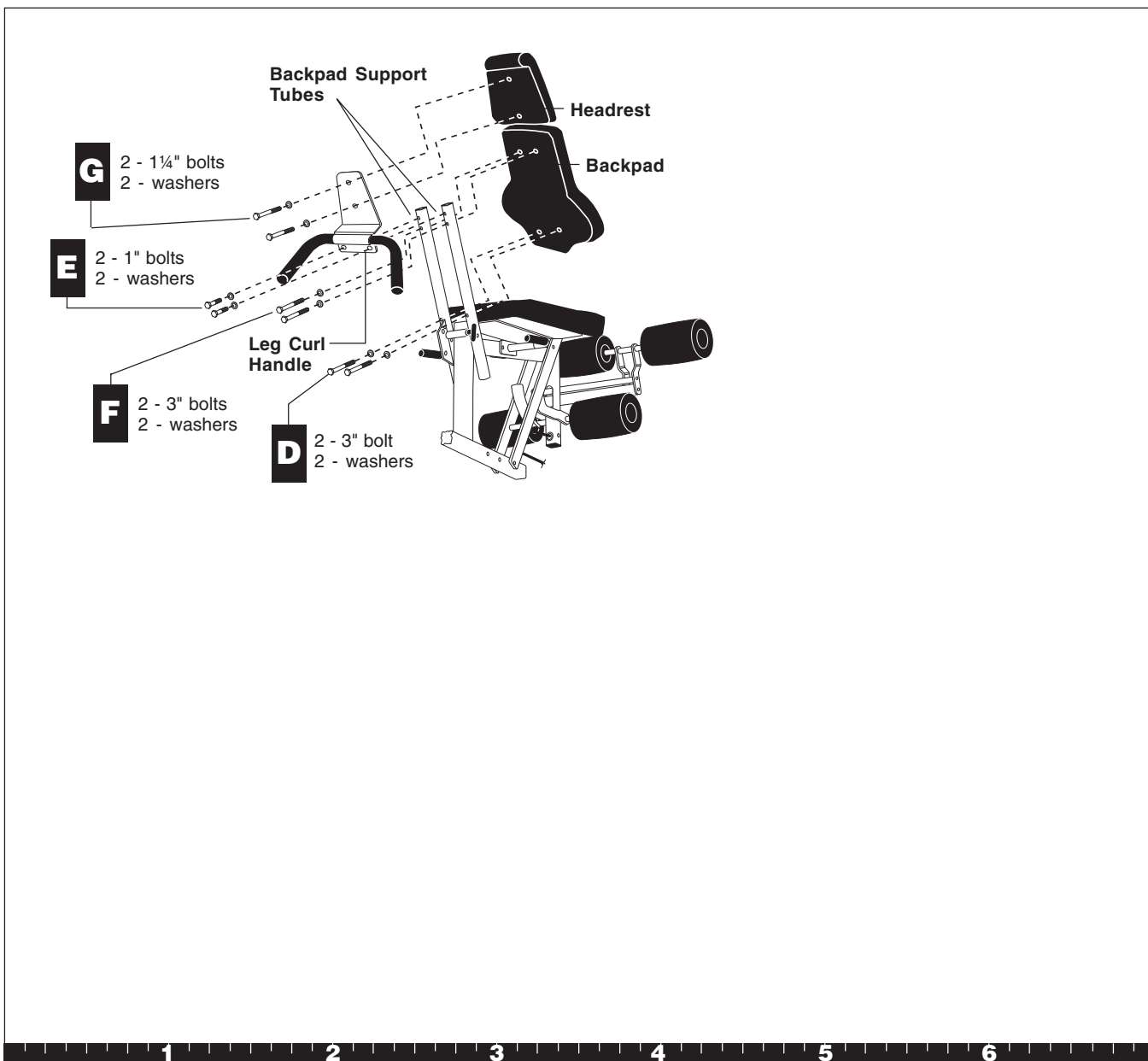

Step 6. Assemble Leg Curl Seat, Continued

Open Box 3

Use tie cutters to open the box.

The diagram shows how the S3.25 will look after you complete this section.

Note: Some items in these boxes may not be needed until later in the assembly process.



Open Box 3

7. Assemble Chest Press Seat

- A. Attach the Chest Press Upright to the Chest Press Seat using
four ¾-inch bolts
four washers
Finger tighten.
- B. Attach the middle hole at top of the Chest Press Upright to the Main Upright using
one 3½-inch bolt
one washer
Finger tighten.
- C. Attach the lower hole at the top of the Chest Press Upright to the Main Upright using
one 3½-inch bolt
one washer
- D. Attach the Chest Press Seat to the Chest Press Base using
one 3-inch bolt
two washers
one locknut
Finger tighten.
- E. Wrench tighten all bolts.
- F. Attach the Prestretch Tube to the Main Upright using
two 3½-inch bolts
six washers
Wrench tighten.
- G. Wrench tighten all bolts.

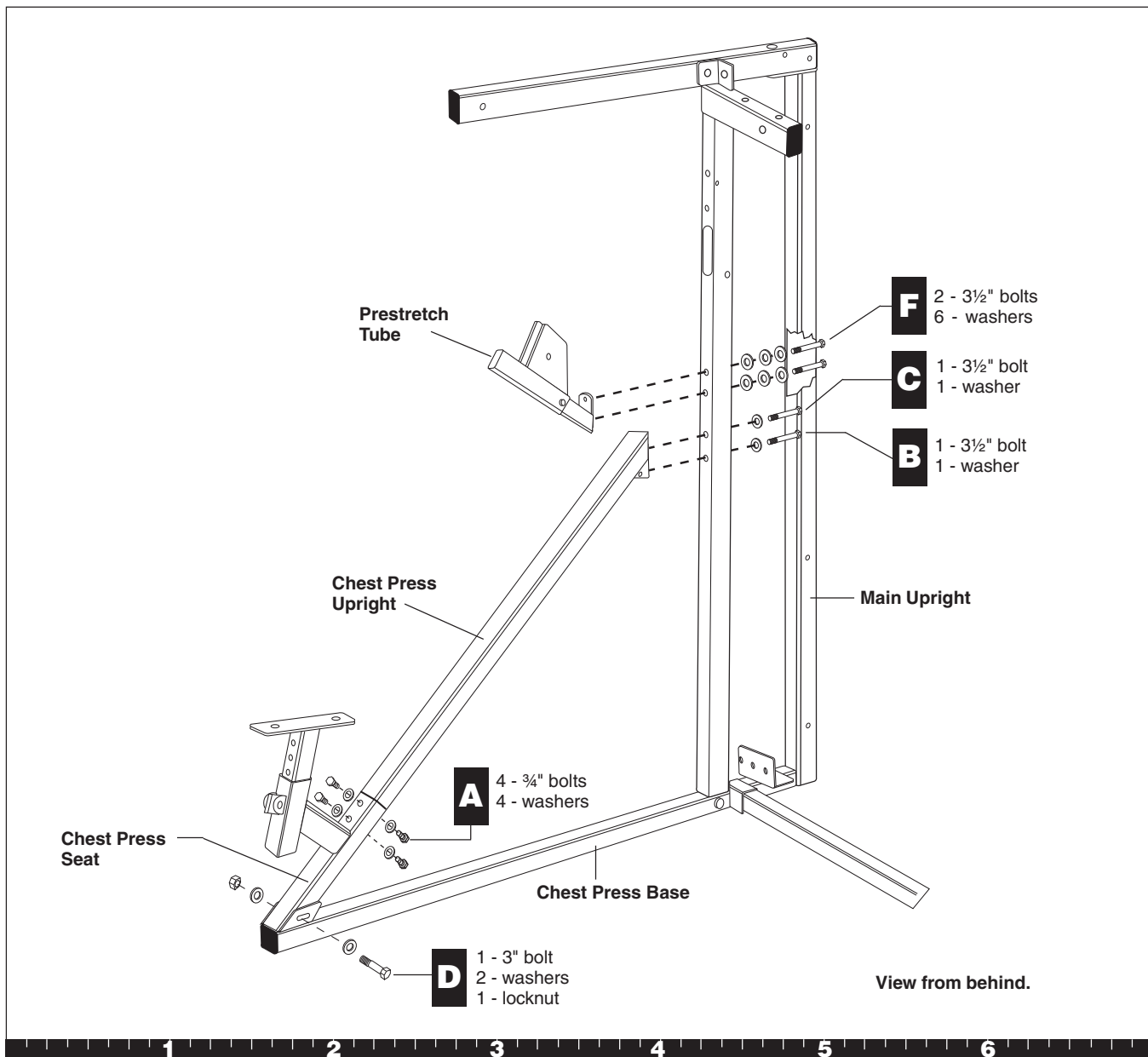

Step 7. Assemble Chest Press Seat

8. Attach Press Arm Assembly

CAUTION: This step requires two people. Do not pinch yourself between the Press Arm and the Prestretch Tube.

- A. Attach the Press Arm Assembly to the Main Upright using two 4-inch bolts, four washers, and two locknuts. Wrench tighten.
- B. Check the alignment of the Press Arm Assembly and Prestretch Tube. Wrench tighten.
- C. Use the supplied allen wrench and tighten the set screws.

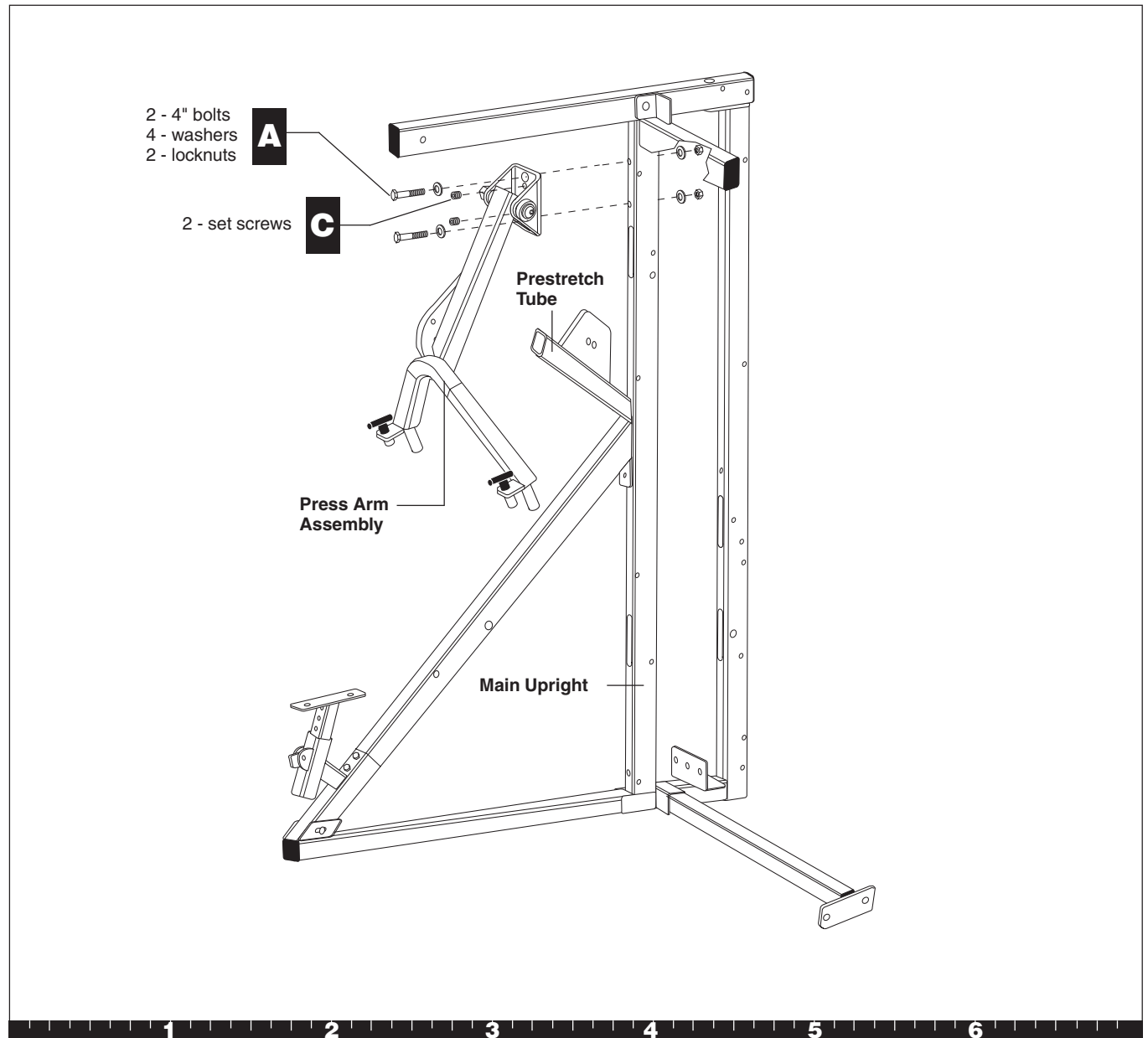

Step 8. Attach Press Arm Assembly

9. Attach Handlebars

- A. Slide each Handlebar (one at a time) on the Pivot Shaft.
- B. To the end of each threaded Pivot Shaft, attach one ½-inch washer
one ½-inch hat washer
one ½-inch locknut

Note: Tighten the locknut until the Handlebars don't move. Then, *loosen* the locknut about one-half turn until the arms pivot freely. A few threads should show beneath the Pivot Shafts if you've tightened it properly.

- C. Secure the Plastic Caps over the locknuts. A rubber mallet may be a useful tool to lightly tap the caps into place.

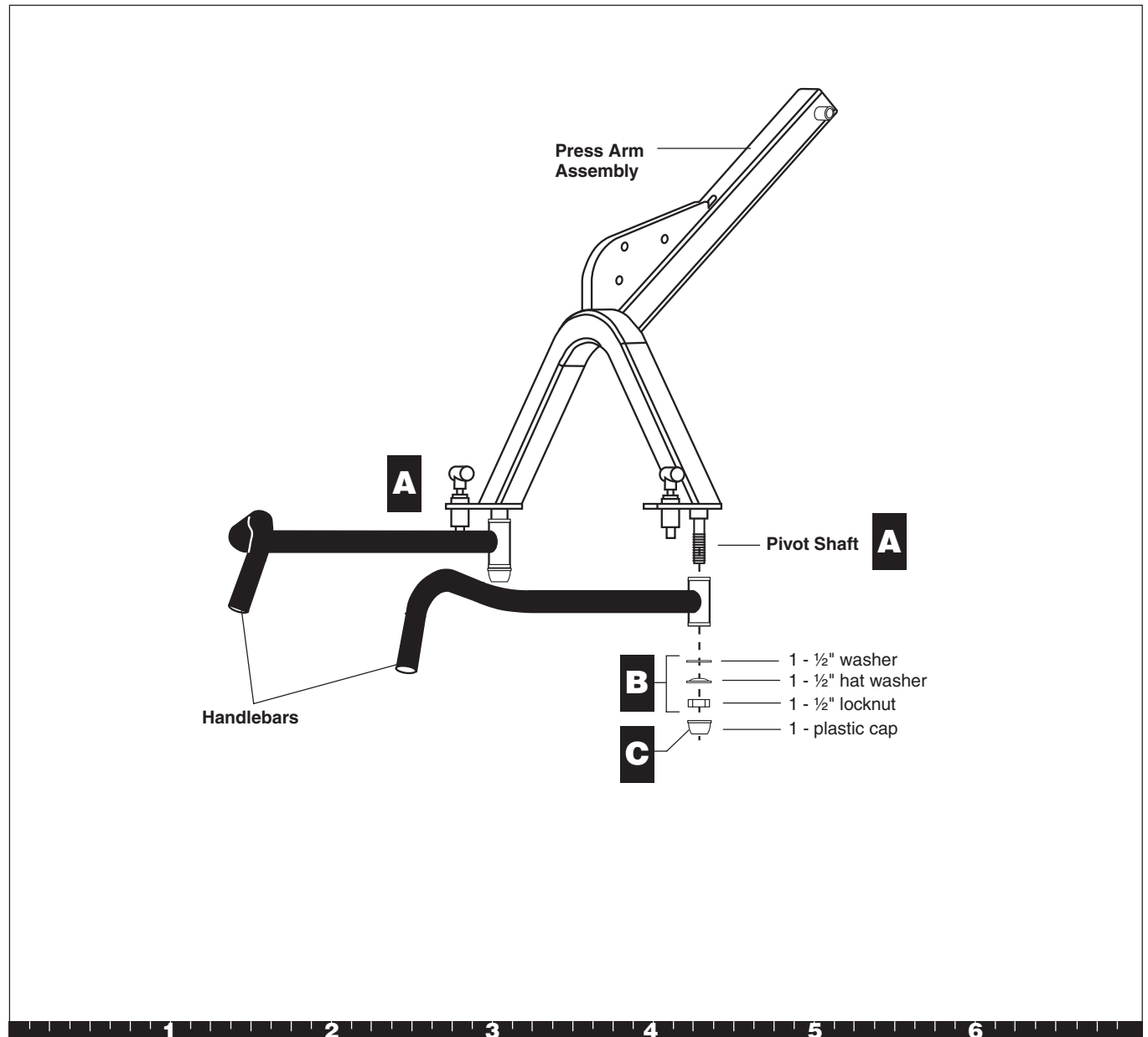

Step 9. Attach Handlebars

10. Assemble Chest Press Seat

- A. Place the Backpad and Headrest on the floor. Place the Long Support Tube and Short Support Tube on the Backpad. Attach at the top using two 1/4-inch bolts two washers
- B. Attach at the bottom using three 3-inch bolts three washers
- C. Attach the Backpad and Headrest assembly to the Chest Press Upright using one 1/2-inch x 5/4-inch bolt two washers one locknut Finger tighten.

Note: The Stop Pad on the seat assembly should be between the Pop Pin and the Support Stop on the Chest Press Upright.

- D. Wrench tighten, still allowing movement.

CAUTION: If you move the Handlebars out of the way for this step, be careful that they don't hit you.

- E. Attach the Seat Pad to the Seat Stem using two 1/4-inch bolts two washers Wrench tighten.

Note: If you have purchased the Leg Press Option, open the S3.25 Leg Press Option box now and begin with Step 2.

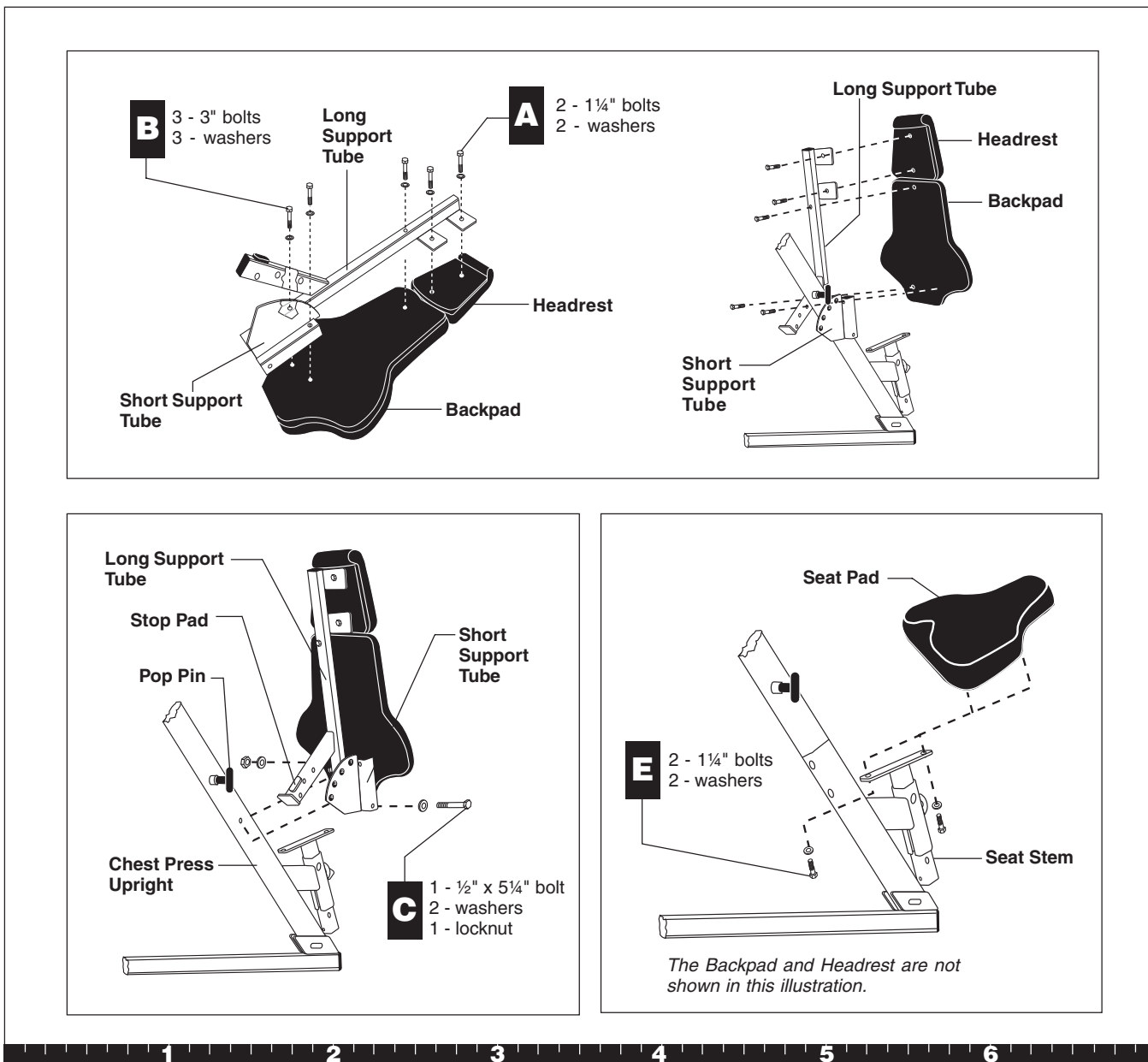

Step 10. Assemble Chest Press Seat

Open Box 4

Use tie cutters to open the box.

The diagram shows how the S3.25 will look after you complete this section.

Note: Set aside the 2 $\frac{3}{4}$ -inch bolt that is wrapped with blue tape. It has special threads than can only be used in step 16E.

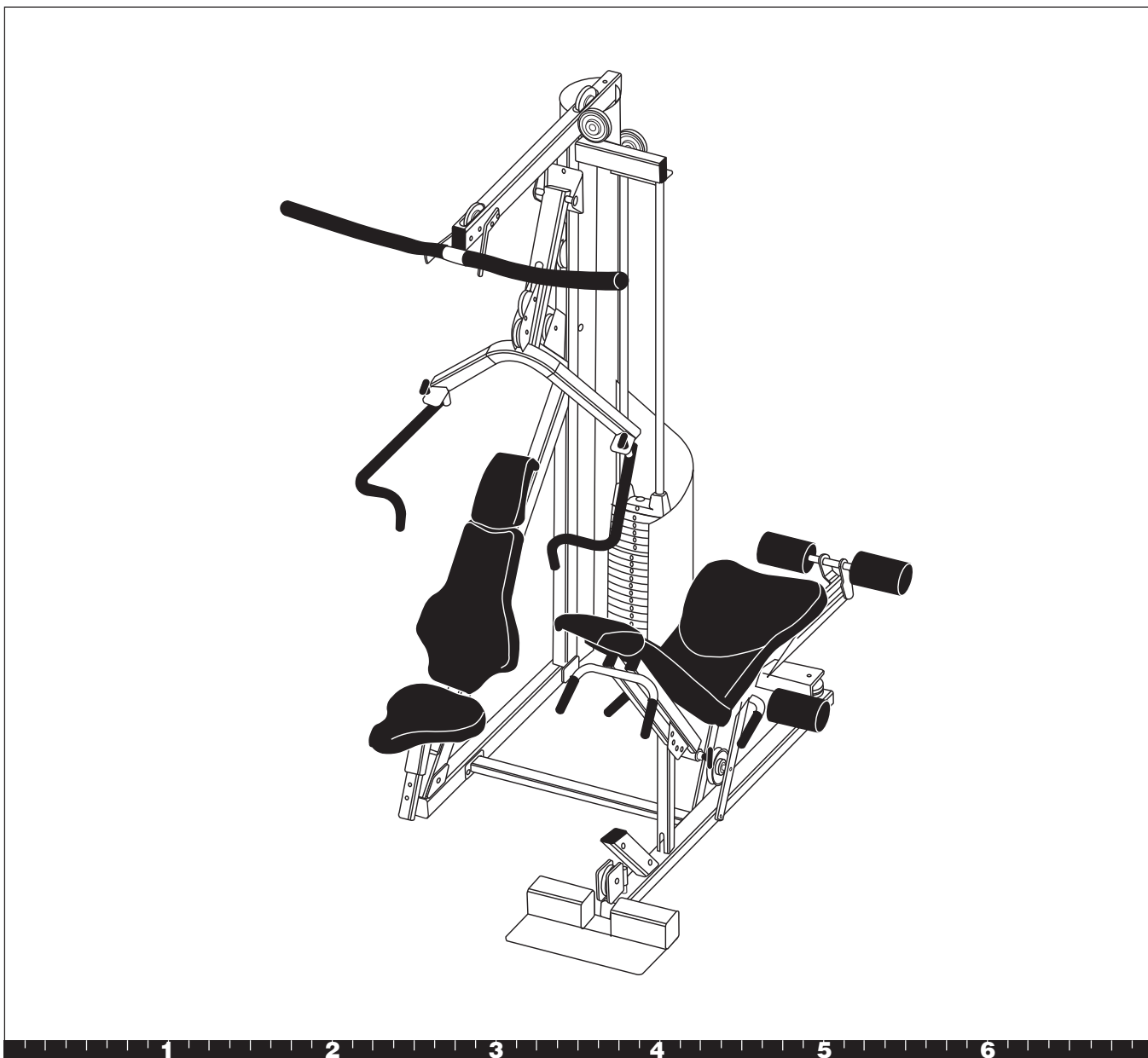

11. Assemble Weight Stack

Important: Position your unit in its permanent location before assembling the Weight Stack.

- A. Place a Weight Cushion on the base of two Guide Rods (found in Box 1).
- B. Insert the Guide Rods in the large holes on the Main Upright Base. The Guide Rods will be unstable until you complete step D. Slide the Weight Stack Cushions onto the top of the Main Upright Base.
- C. Apply one tube of lubricant to each Guide Rod. Avoid getting lubricant on your clothing or on other parts of the machine.

- D. Add the five 15-lb weights, the ten 10-lb weights, and the five 5-lb weights. Note the tab location for the weight stickers (you will attach the stickers later). Hold your finger over the plastic bushing in each weight to prevent the bushing from popping out.

CAUTION: This step requires assistance. The weights are heavy! Handle the weights carefully so as not to drop them or injure yourself. Pick up and place one weight at a time on the Guide Rods. Have someone hold the Guide Rods in place while you slide the weights on the stack.

- E. Position the Top Cap Weight on the Guide Rods so that the hole is inline with the Weight Stack holes.
- F. Insert the retainer pins of the Guide Rod Bracket in the Guide Rods. Attach the Bracket to the Main Upright using two 4-inch bolts, four washers, two locknuts.
- G. Wrench tighten the Weight Stack bolts.

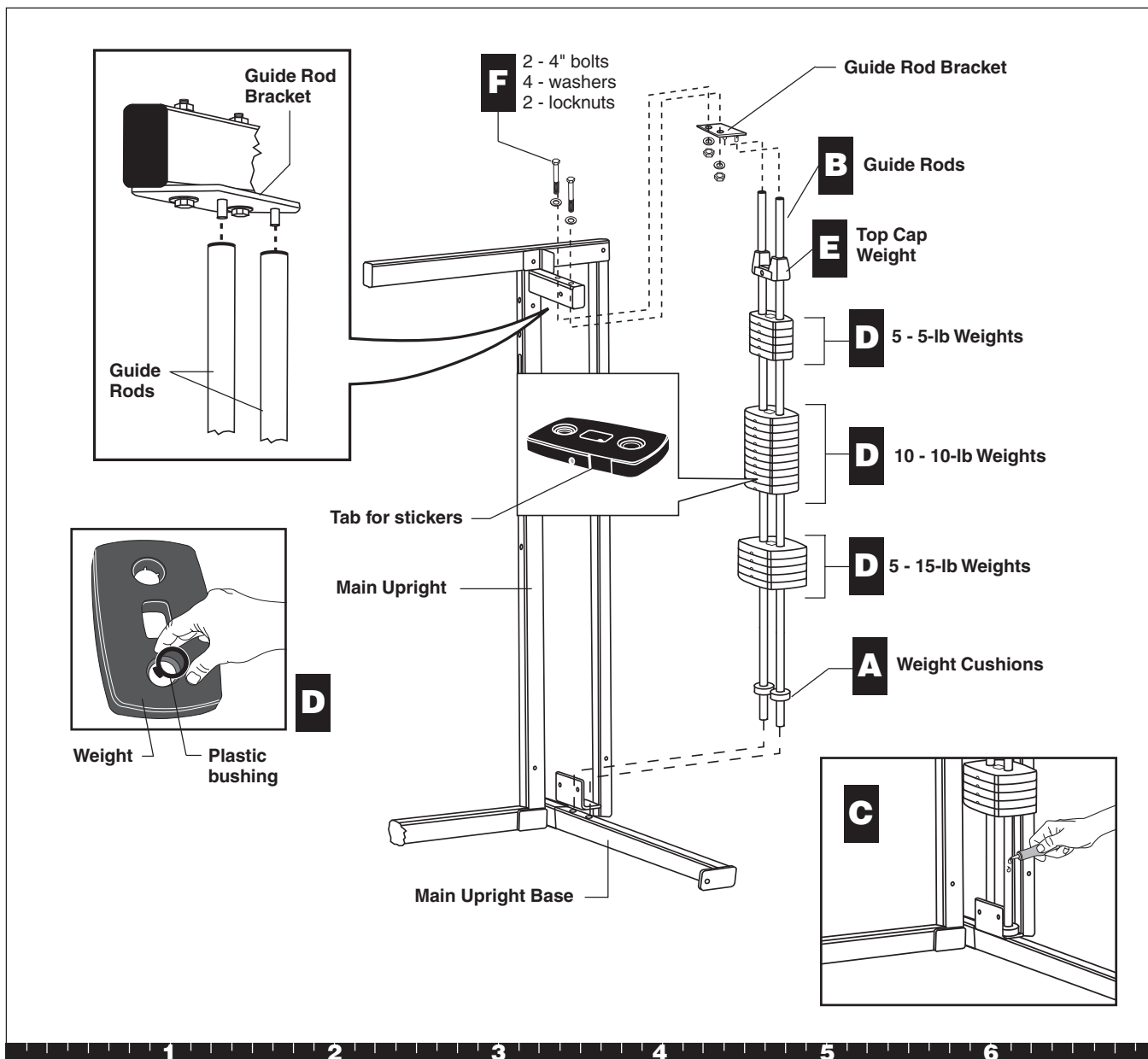

Step 11. Assemble Weight Stack

12. Feed Upper Cable

- A. Attach a 4½-inch pulley to the top of the Main Upright using one 4¼-inch bolt, two washers, one barrel spacer, and one locknut.
- B. Attach a 4½-inch pulley to the Angle Bracket at the top of the Main Upright using one 2½-inch bolt, two washers, one barrel spacer, and one locknut.
- C. Feed the U end of Cable 44370-103 through the pulley window in the Top Beam. Wrap the Cable over a 4½-inch pulley and attach the pulley to the Top Beam using one 2¾-inch bolt, two step spacers, and one locknut.
- D. Create a retainer pin in the remaining hole of the Top Beam using one 2¾-inch bolt, two washers, and one locknut.
- E. Run the cable above the Top Beam and down through the next pulley window and around a 4½-inch pulley. Attach the pulley to the Top Beam using one 3½-inch bolt, two step spacers, one locknut, one washer, one barrel spacer, and one surgical tube. Wrench tighten.
- F. Wrap the Cable around the pulleys as indicated in the diagram and through the hole in the Guide Rod Bracket.

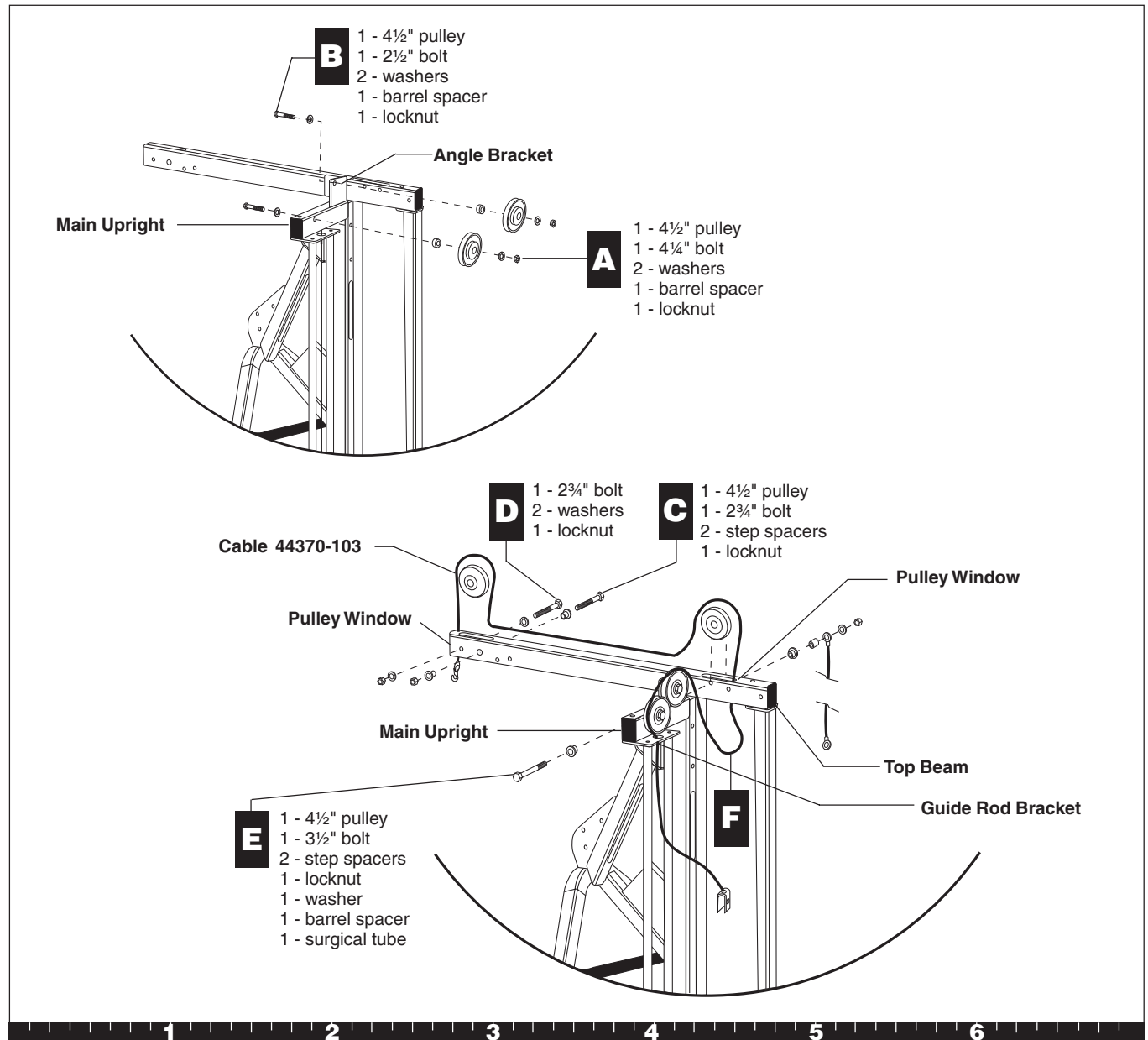

Step 12. Feed Upper Cable

- G. Insert the Selector Stem in the Weight Stack with the threaded hole at the top. Hold the Selector Stem with several holes above the Cap Plate. Insert the Weight Pin to suspend the Selector Stem. Place the loop end of the Weight Pin Lanyard into the U end of the Cable. Align the U end of the Cable, the top of the Selector Stem, and the Cap Plate. Attach using one 1½-inch socket cap bolt
- H. Wrench tighten. Remove the Weight Pin and lower the cap plate.

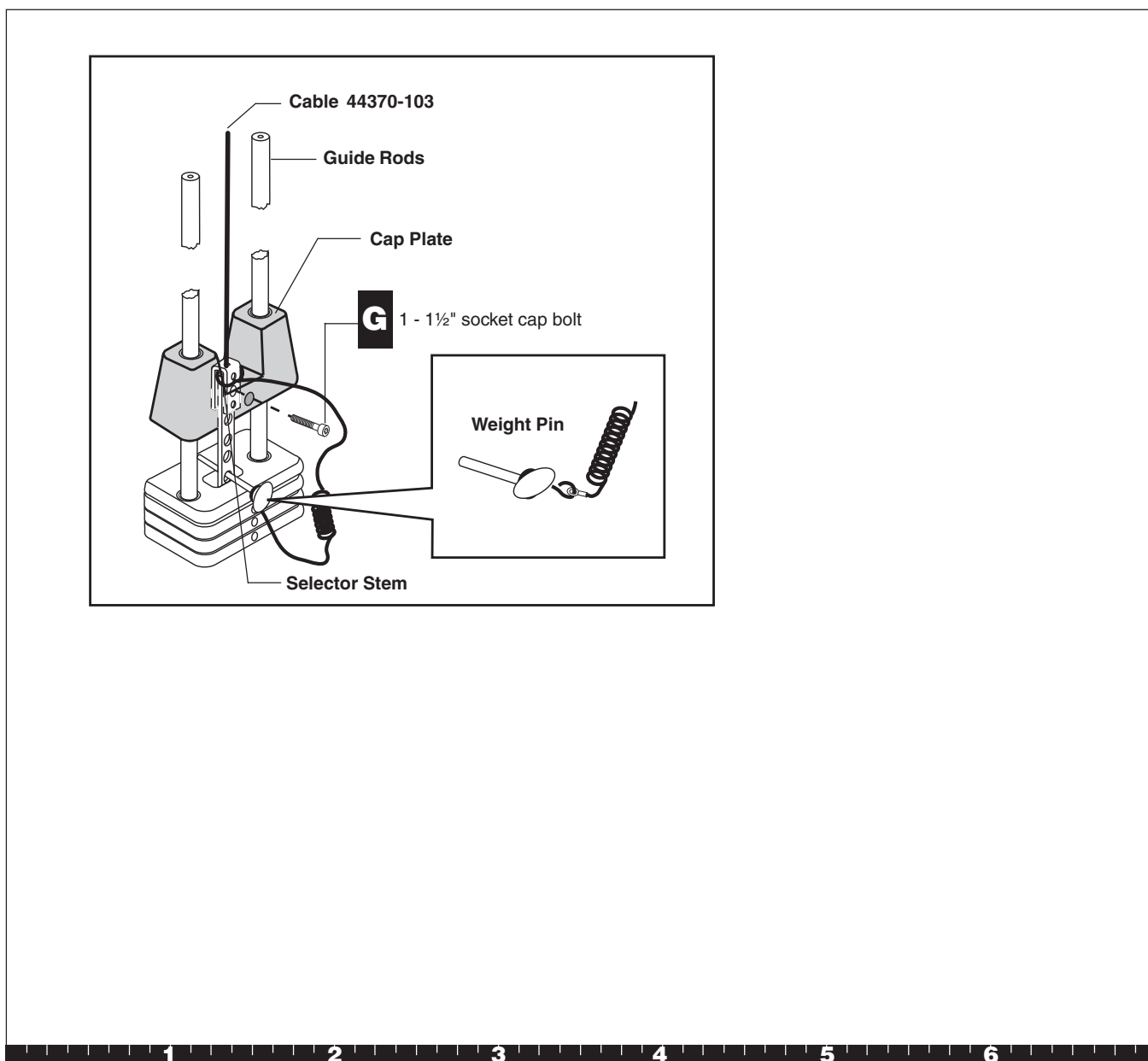

Step 12. Feed Upper Cable, Continued

13. Attach Lat Bar Holders

- A. Attach the Lat Bar Holders to the Top Beam using two 3/4-inch bolts, four washers, and two locknuts.
- B. Wrench tighten.

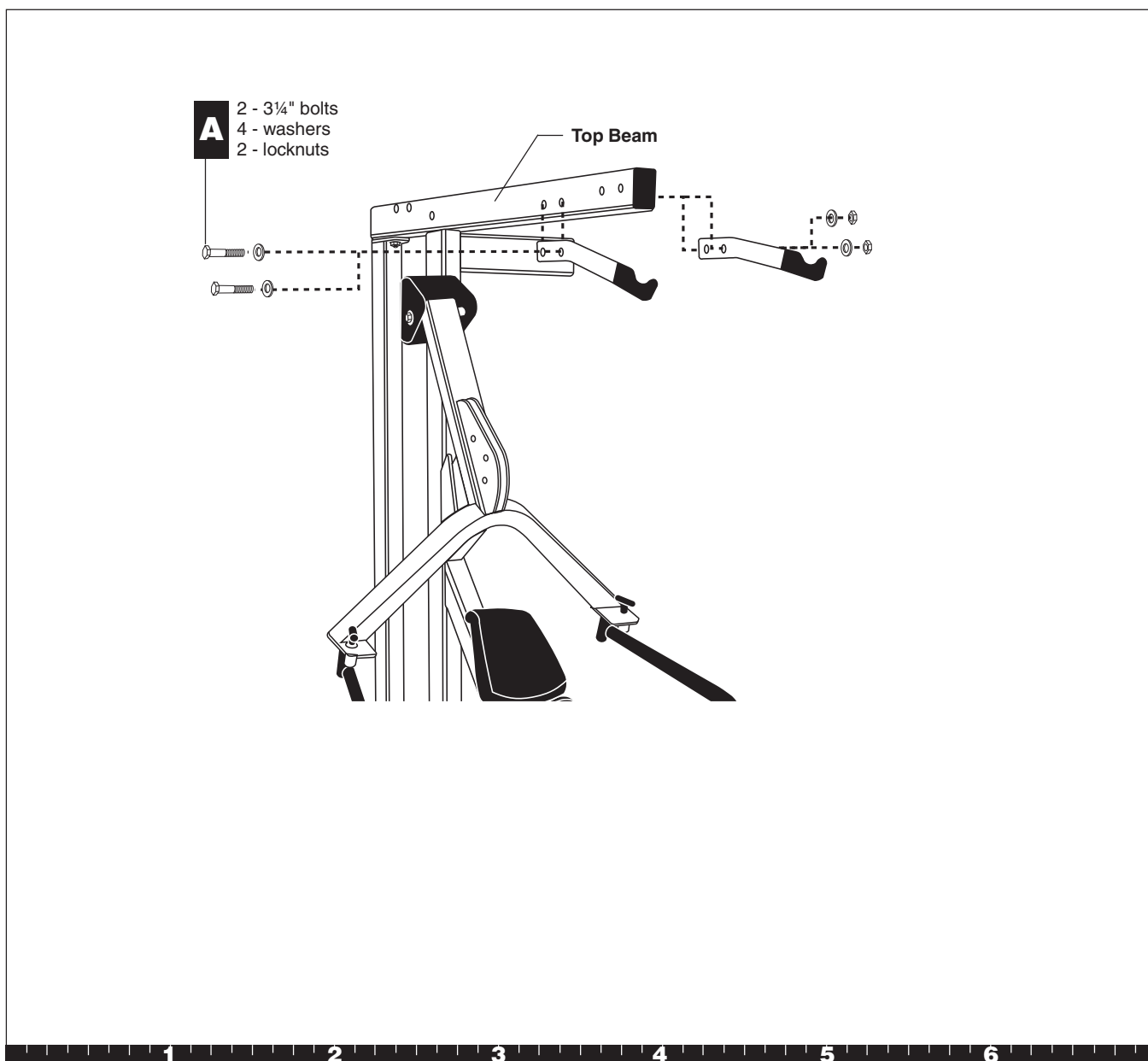

Step 13. Attach Lat Bar Holders

14. Feed Cable From Cable Tree

- A. Feed the Spring Clip end of Cable 44371-103 under a 4½-inch pulley, through the lower pulley window of the Main Upright, and through the upper pulley window of the Main Upright. Attach the pulley to the lower pulley window using
 - one 2¾-inch bolt
 - two step spacers
 - one locknut
- B. Wrap the cable over a 4½-inch pulley and attach it to the upper pulley window using
 - one 2¾-inch bolt
 - two step spacers
 - one locknut
- C. Feed the Cable over one 4½-inch pulley and attach it to the upper hole in the Press Arm Flats using
 - one 2-inch bolt
 - two washers
 - one locknut
 Finger tighten.
- D. Ensure the Cable wraps around the pulley and then feed the Cable back through the Press Arm Flats. Wrap the Cable over and around one 4½-inch pulley and attach it to the Prestretch Tube using
 - one 2-inch bolt
 - two washers
 - one cam washer
 - one locknut
 Finger tighten.

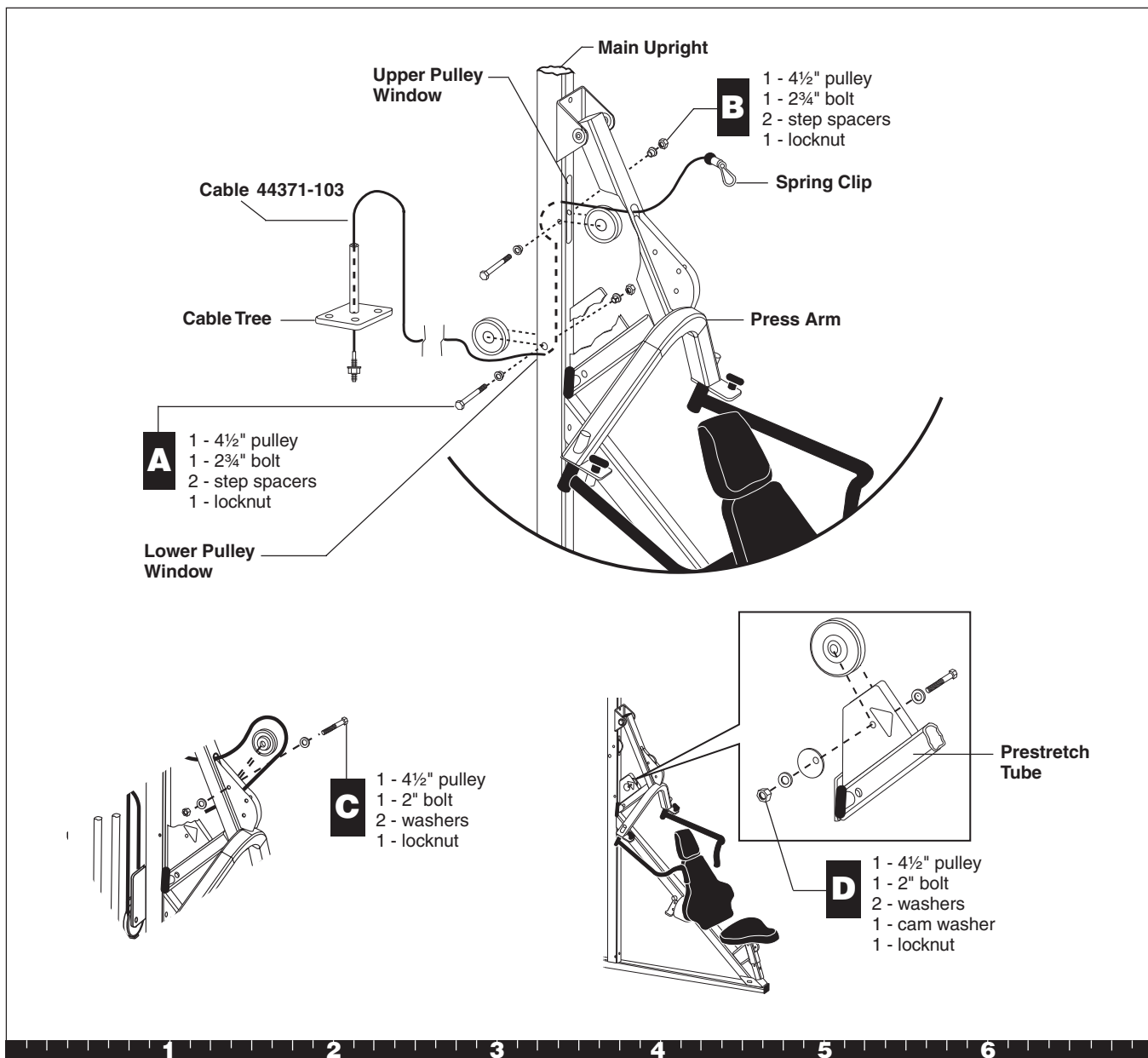

Step 14. Feed Cable From Cable Tree

- E. In the middle hole on the Press Arm Flats, make a retainer pin using one 2-inch bolt, two washers, one barrel spacer, one locknut. Finger tighten.
- F. Wrap the Cable over one 3½-inch pulley and attach it to the bottom hole on the Press Arm Flats using one 2-inch bolt, two washers, one locknut.
- G. Wrench tighten. Do not overtighten.
- H. Attach two large floating Pulley Plates (found in Box 2) to one 4½-inch pulley using one 2-inch bolt, two washers, one locknut. Finger tighten.
- I. Place the pulley on the cable loop from Cable 44370-103.
- J. Loop center Cable 44371-103 from the Cable Tree around a 4½-inch pulley and attach it to the remaining holes in the floating Pulley Plates using one 2-inch bolt, two washers, one locknut.
- K. Wrench tighten.

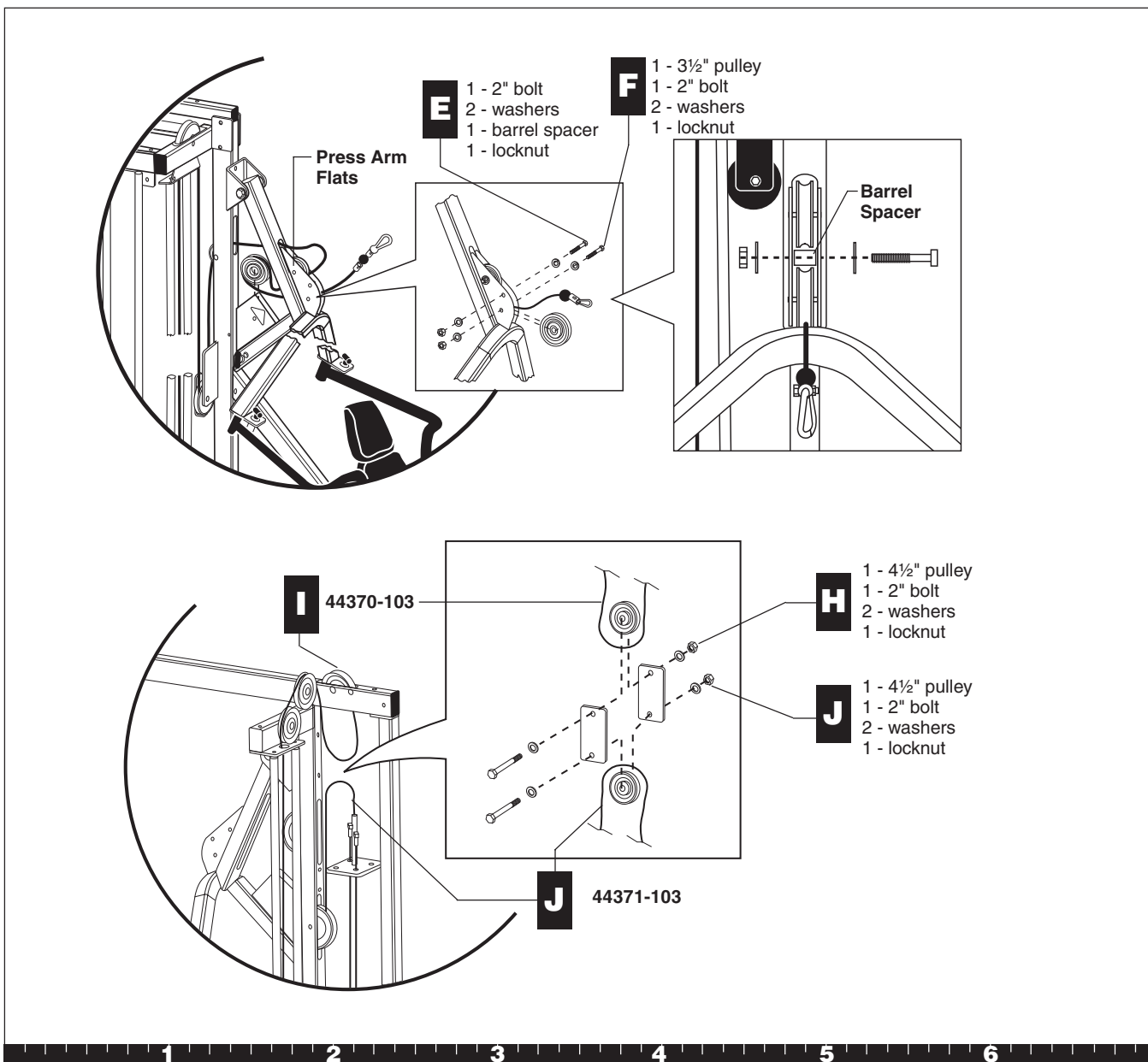

Step 14. Feed Cable From Cable Tree, Continued

15. Attach Leg Curl Cables to Lower Pulley Bracket

- A. Wrap Cable 44376-102 around a 3½-inch pulley so that the U end of the Cable faces up toward the Cable Tree. Attach it and a Cable Retainer to the left hole of the Lower Pulley Bracket at the base of the Rear Upright using
 - one 2-inch bolt
 - two washers
 - one locknut
- B. Wrap Cable 44375-103 around a 3½-inch pulley so that the U end of the Cable faces up toward the Cable Tree. Attach it and a Cable Retainer to the back side of the middle hole of the Lower Pulley Bracket using
 - one 2-inch bolt
 - two washers
 - one locknut
- C. Wrench tighten.

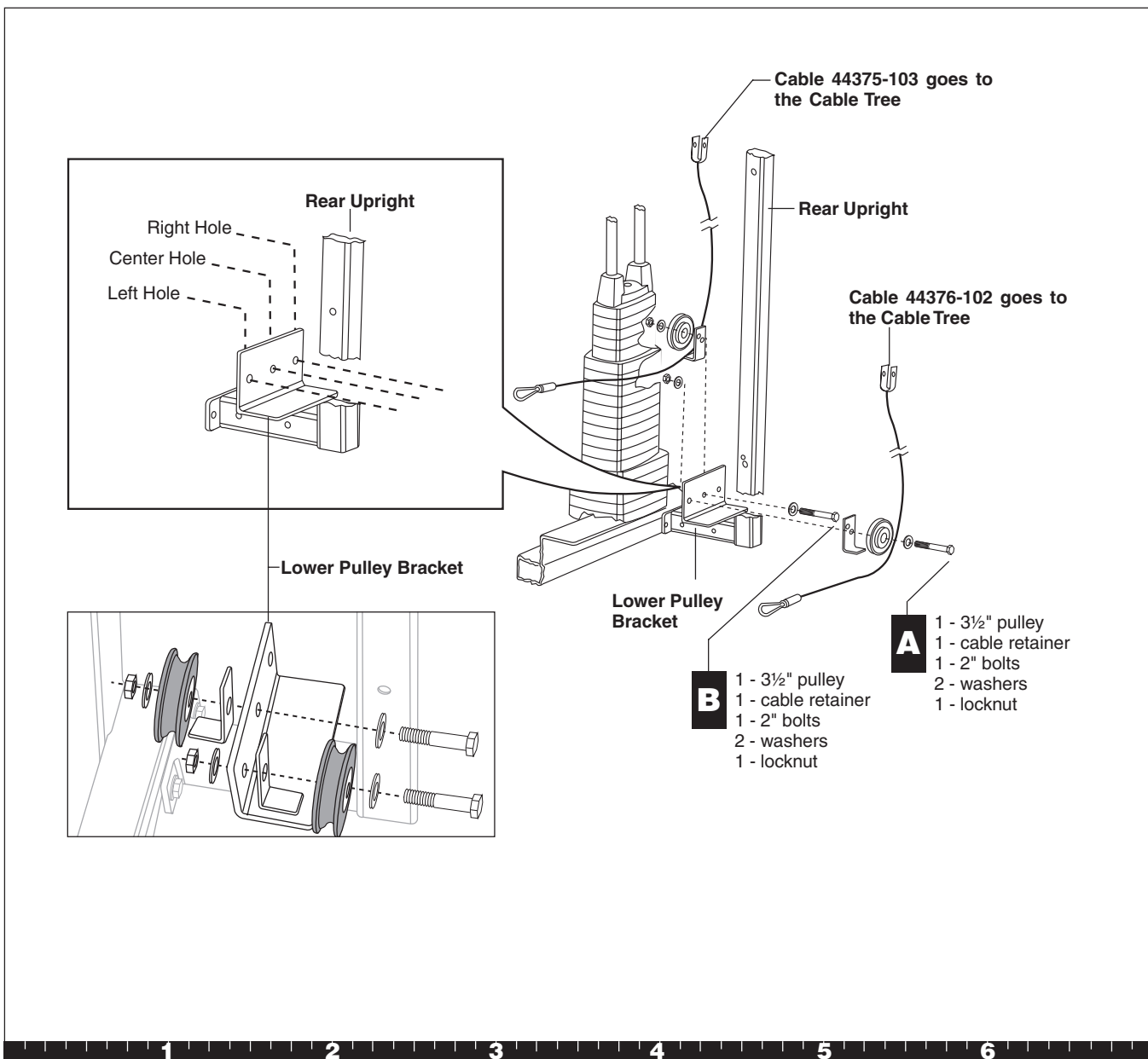

Step 15. Attach Leg Curl Cables to Lower Pulley Bracket

16. Attach Leg Curl Cables to Seat Upright

A. Attach the Pulley Cover to the Main Upright Base using
 one 2¾-inch bolt (without blue tape)
 two washers
 one locknut
 Finger tighten.

B. Place two 3½-inch pulleys on top of each other on the Seat Extension.

C. Wrap Cable 44375-103 around the bottom pulley at the end of the Seat Extension between the pulley and the retainer pin.

D. Wrap Cable 44376-102 around the top pulley at the end of the Seat Extension between the pulley and the retainer pin.

Important: Be sure to use the 2¾-inch bolt wrapped with the blue tape in step E.

E. Attach using
 one 2¾-inch bolt (with blue tape)
 one washer

F. Use the remaining hole in the Pulley Cover to attach the Pulley Cover to the Main Upright Base using
 one 2¾-inch bolt
 two washers
 one locknut
 Finger tighten.

G. Wrench tighten all bolts.

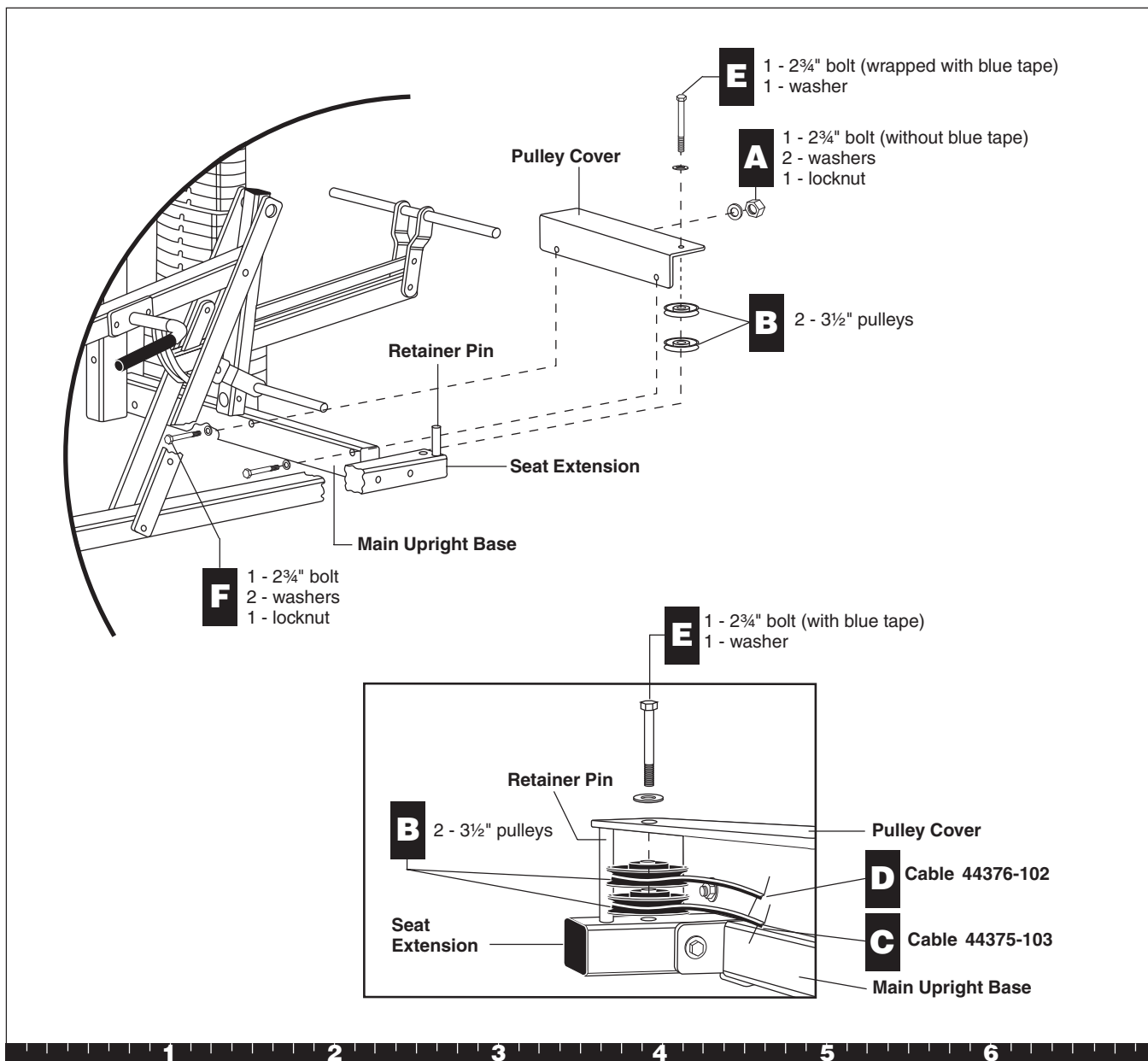

Step 16. Attach Leg Curl Cables to Seat Upright

17. Feed Top Cable 44376-102

- A. Attach Cable 44376-102 to the Rotating Arm using
 one 2¾-inch bolt
 two step spacers
 one locknut
- B. Wrap the Cable around a 4½-inch pulley and
 attach it and a cable retainer to the Upright Flats using
 one 4½-inch bolt
 two washers
 one ⅜-inch barrel spacer
 three ½-inch barrel spacers
 one locknut

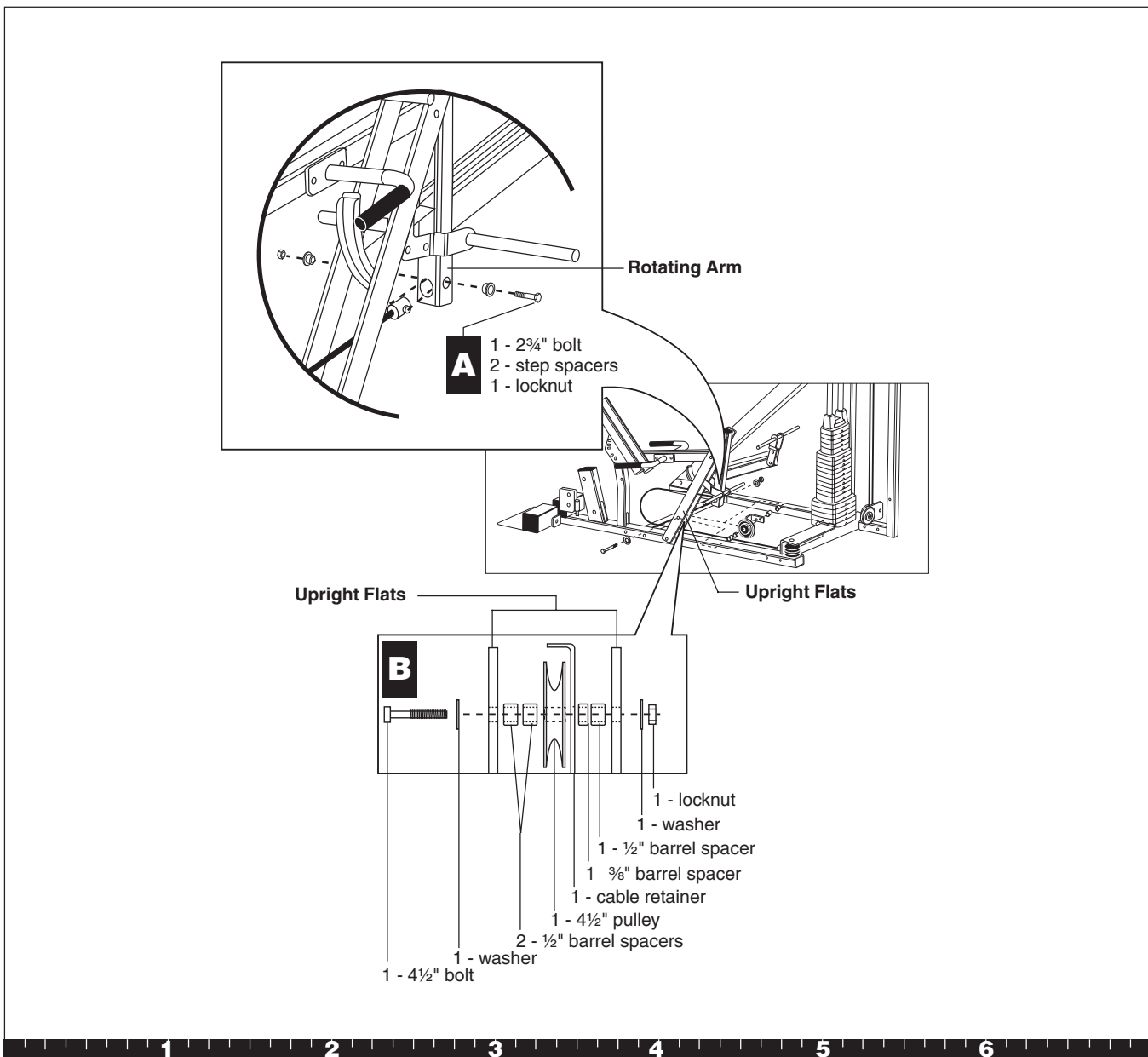

Step 17. Feed Top Cable 44376-102

18. Feed Bottom Cable 44375-103

- A. Feed Cable 44375-103 through the Upright Flats, through the Seat Upright Window, and into the Pulley Window at the end of the Seat Upright.
- B. Review the diagram and feed the Cable around one 3½-inch pulley. Attach the pulley using one 2¾-inch bolt, two step spacers, one locknut.
- C. Wrap the Cable over a 3½-inch pulley and attach it using one 2¾-inch bolt, two step spacers, one locknut. Finger tighten.
- D. Insert a 2-inch bolt as a retainer pin through the base of the End Pulley Bracket. Attach it using two washers, one locknut.
- E. Feed the Cable between the retainer pin and hole in the End Pulley Bracket. Attach the 3½-inch pulley to the End Bracket using one 2-inch bolt, two washers, one locknut. Finger tighten.

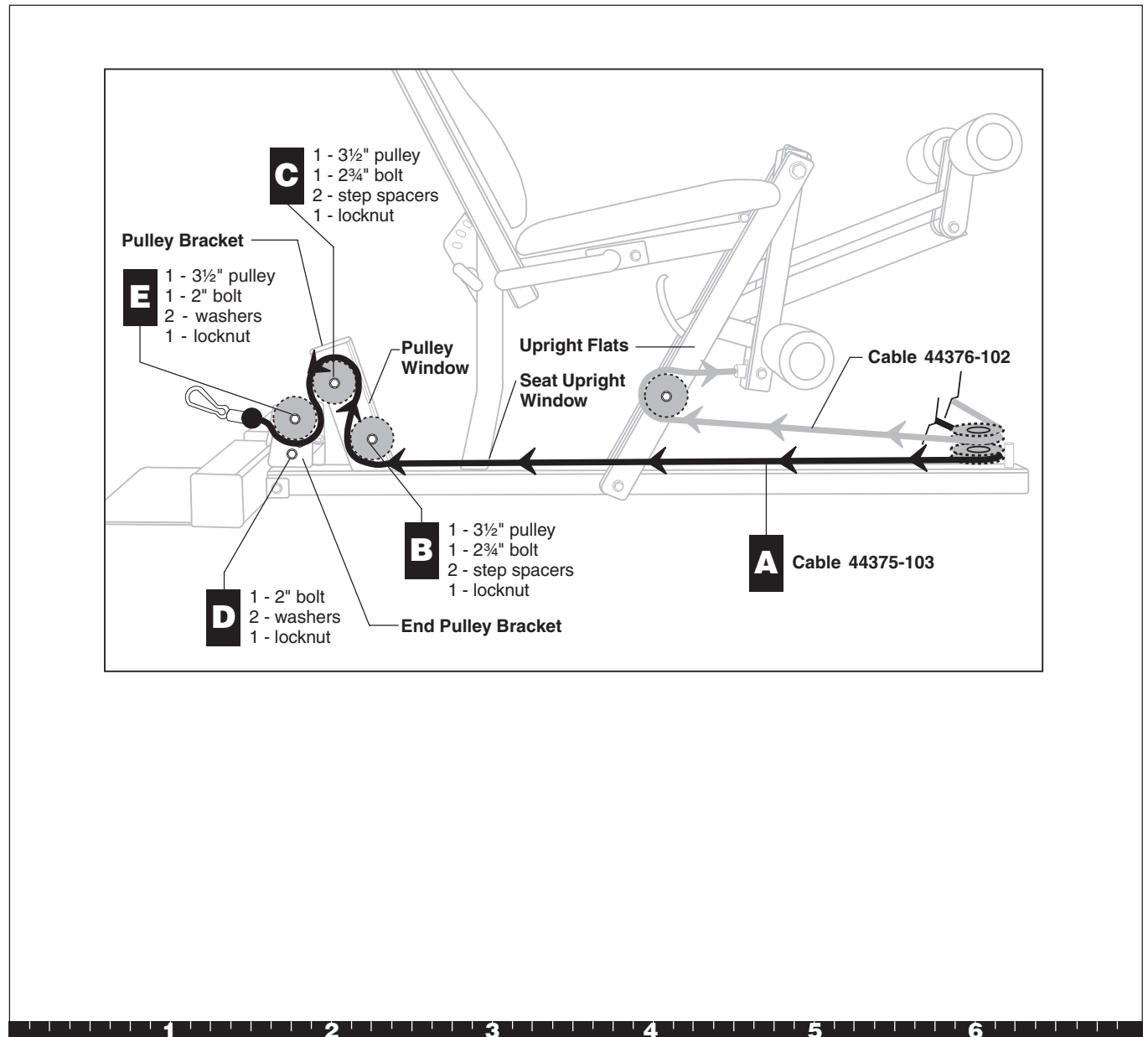

Step 18. Feed Bottom Cable 44375-103

19. Attach Surgical Tubing to Top Beam

- A. Attach the other end of the surgical tubing to the Top Beam using
one 3/4-inch bolt
two washers
one 1/2-inch barrel spacer
one locknut
Wrench tighten.

CAUTION: Surgical tubing may cause injury if allowed to snap back as you pull the rubber tubing tightly.

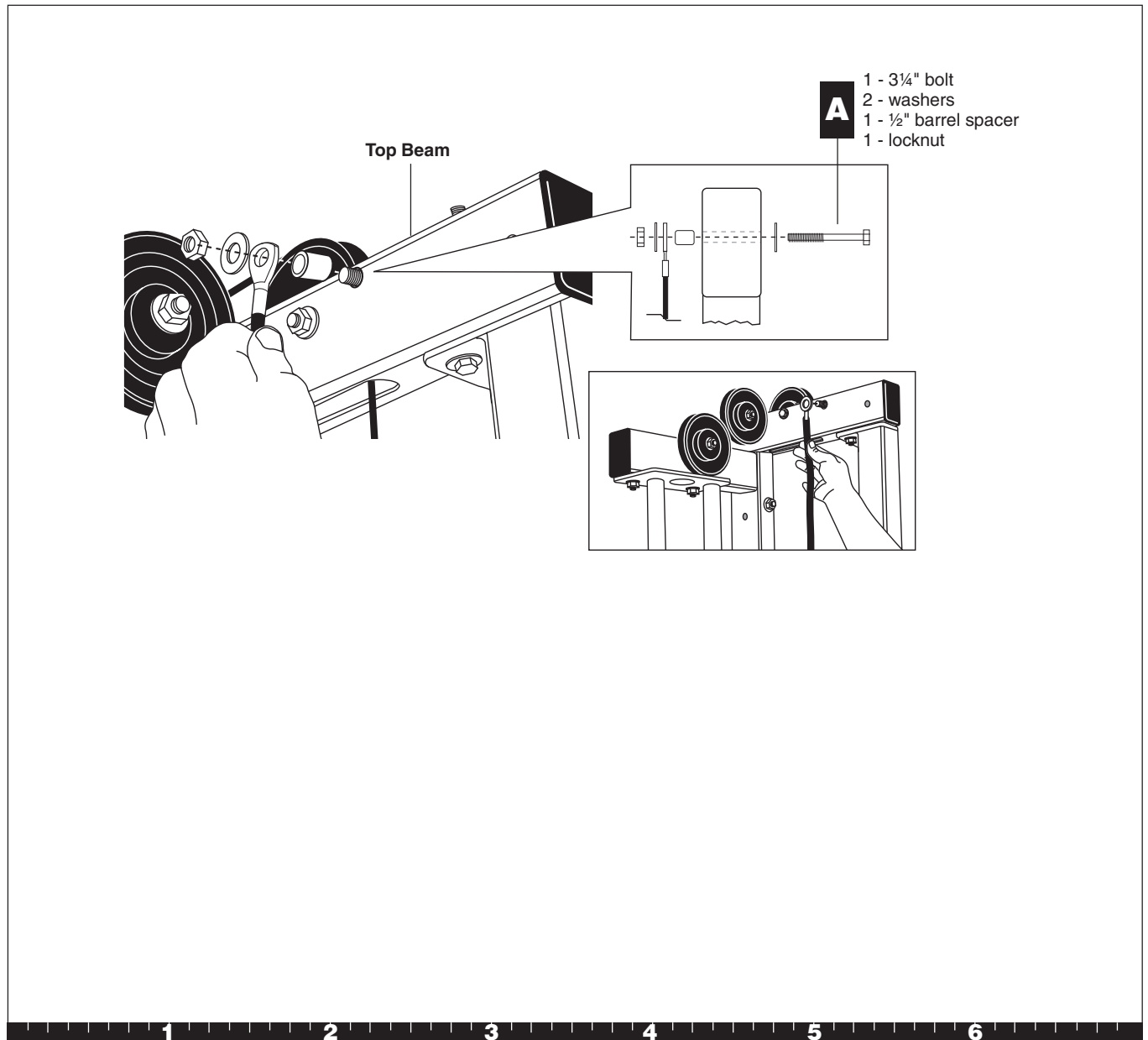

Step 19. Attach Surgical Tubing to Top Beam

20. Attach Leg Curl Cables to Cable Tree

- A. Remove the U end of Cable 44376-102. Insert the Cable in one of the corner holes of the Cable Tree. Reattach the U end of the Cable with surgical tubing.
- B. Remove the U end of Cable 44375-103. Insert the Cable in the opposite corner of the Cable Tree. Reattach the U end of the Cable with surgical tubing.

Note: If you are assembling the Leg Press Option simultaneously, go to Step 5 in the *S3.25 Leg Press Option Assembly Instructions* now.

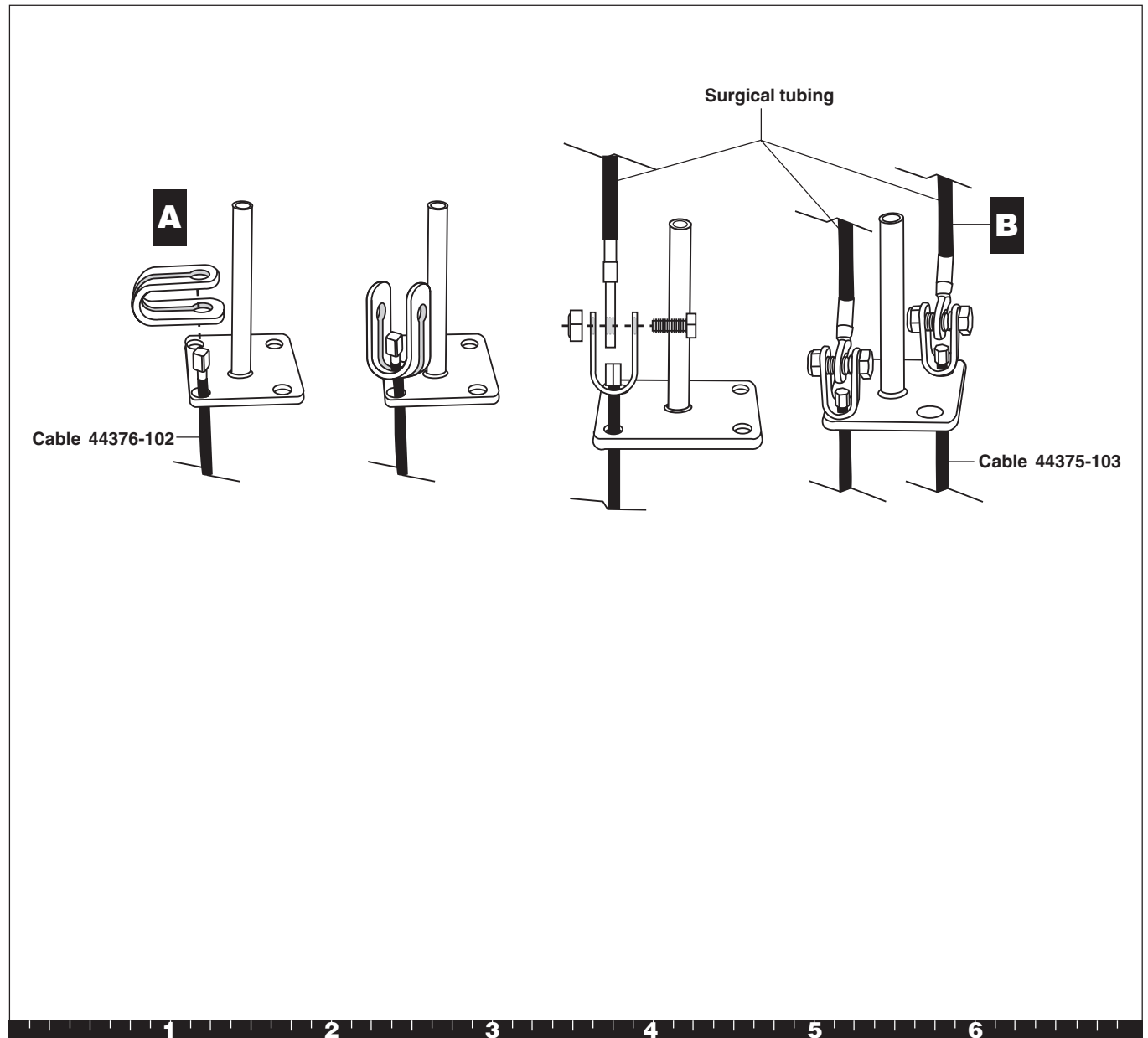

21. Attach Accessories

- A. Attach the Lat Bar to the Spring Clip at the end of the Top Beam.
- B. Attach the Ab Crunch Strap to the Spring Clip on the Press Arm.
- C. Attach the Ankle Strap to the Spring Clip on the Leg Station.
- D. Attach the 18-inch Straight Bar to the Spring Clip on the Leg Station to work out a different muscle group.

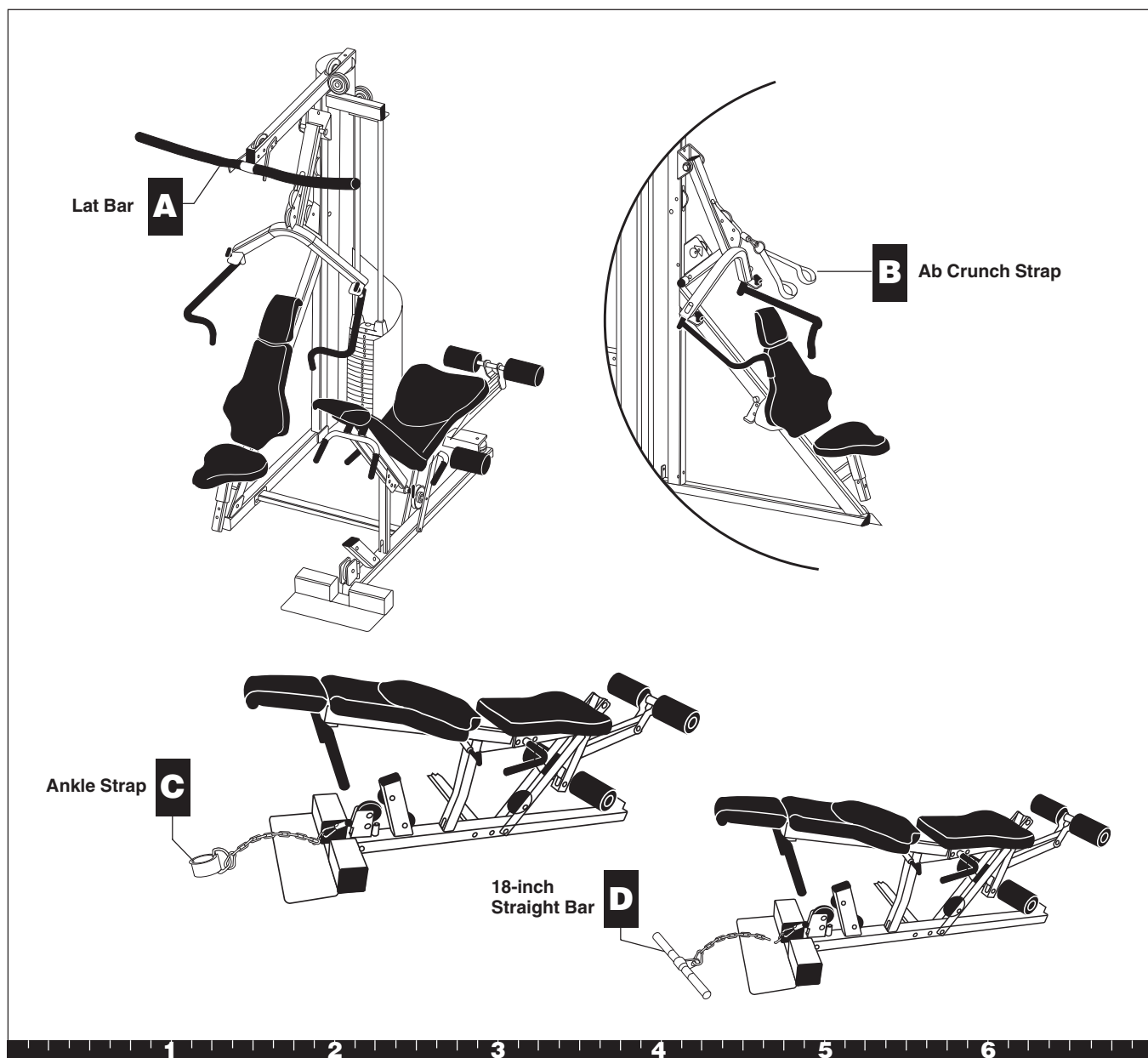

22. Attach Shrouds

Important: Before attaching the Shrouds, make any necessary adjustments. Refer to Chapter 4, "Adjustments and Maintenance" on page 36 for instructions.

- A. Place one Large Shroud on each side of the Main Upright and Rear Upright and attach using
 - six 2 $\frac{3}{4}$ -inch bolts
 - twelve washers
 - six locknuts
- B. Place the Small Shroud around the Weight Stack and attach it to the Large Shroud using
 - two $\frac{3}{4}$ -inch bolts
 - two washers
- C. Attach the Small Shroud to the Angle Bracket in the Main Upright Base using
 - one $\frac{3}{4}$ -inch bolt
 - one washer

This completes the assembly of your Precor S3.25.

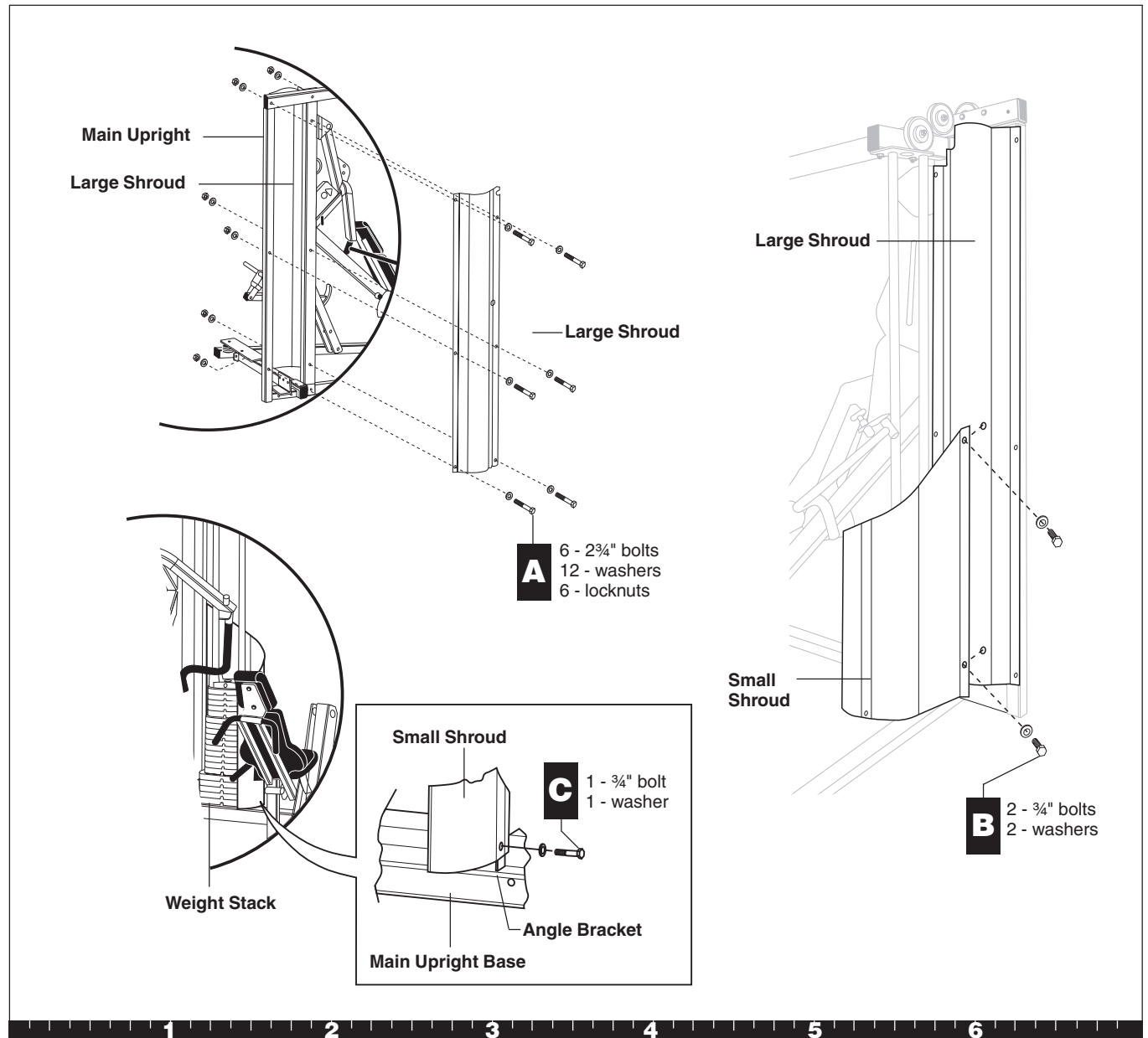

Step 22. Attach Shrouds

4

Adjustments and Maintenance

After the S3.25 is completely assembled, you must check the Cables for proper tension. Obvious signs that Cable problems exist include:

- ✓ The Cap Plate does not rest squarely on the top weight of the Weight Stack.
- ✓ The Cable rubs the inside edges of the pulleys.
- ✓ Excess slack exists in the Cable.

CAUTION: Take the time to perform the following steps. If the Cables do not have the proper tension, you could void the Precor Limited Warranty.

1. Cable Adjustments

- A. Place the Weight Pin in the Top Cap to ensure the least Cable resistance.
- B. To remove slack from the Cable, pull up on the Chest Press Handlebars and adjust the cam washer.
- C. Lower the Chest Press Handlebars.
- D. Check the weights. Move the Weight Pin to each weight plate and Selector Stem location.

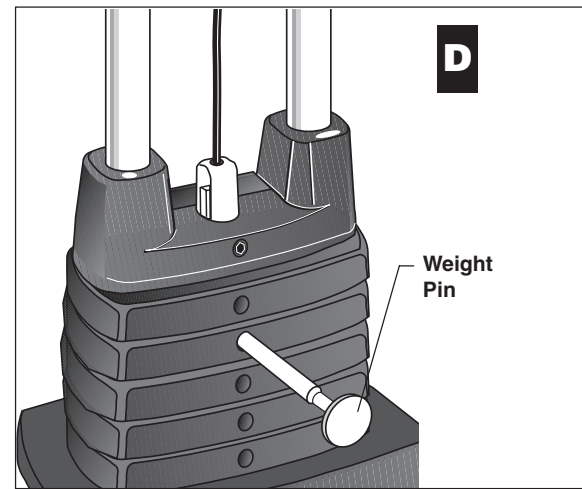
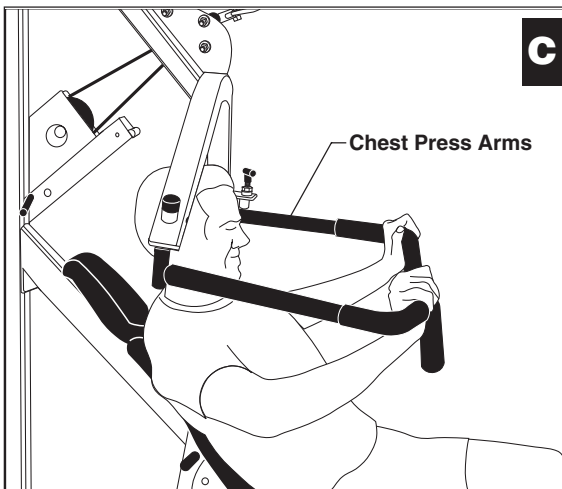
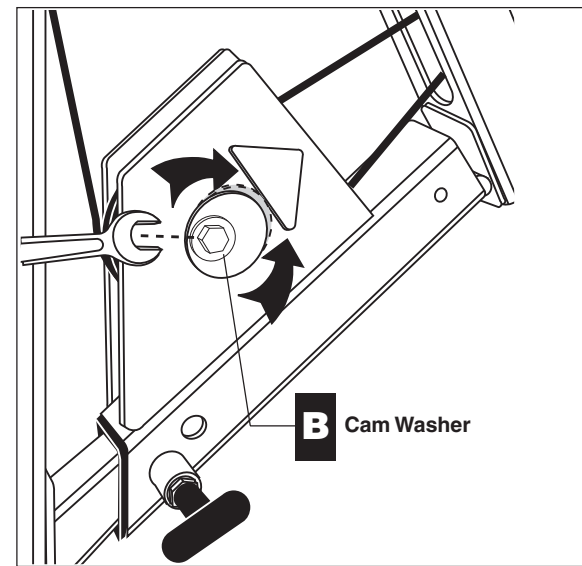
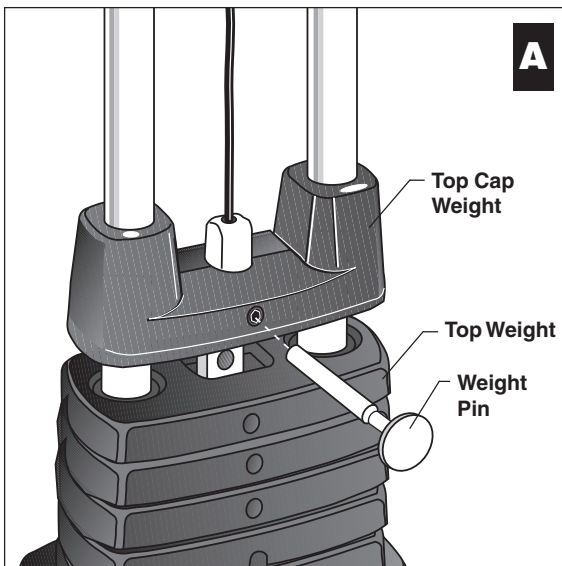

2. Selector Stem Adjustments

To prevent the Selector Stem from contacting the inside of the Weight Stack when the machine is in use, you need to check the vertical angle of the Selector Stem (steps A and B). If the stem slides smoothly without contacting the inside of the weight plates, assembly of the unit is complete.

Caution: Performing the following tasks requires two people.

- A. Remove the Weight Pin from the Weight Stack.
- B. Perform an exercise using each part of the S3.25. When the base of the Selector Stem is clear of the Weight Stack, observe the position of the Selector Stem.

The following sections describe how to adjust the Selector Stem when contact does occur.

The Selector Stem can be adjusted forward or backward, depending on the area of contact.

Forward Angle Adjustment

When the Selector Stem angles forward (toward the seat) and contacts the inside of the Weight Stack during use, adjust it by taking these steps:

Caution: This adjustment requires two people.

- A. Completely disassemble the Cap Plate, Selector Stem, and Cable Clamp.
- B. Thread Allen head set screw into the hole closest to the top of the U end of the cable and turn clockwise until the end of the screw is flush with the inside surface of the clamp.
- C. Turn the set screw clockwise another one-half turn (see diagram).

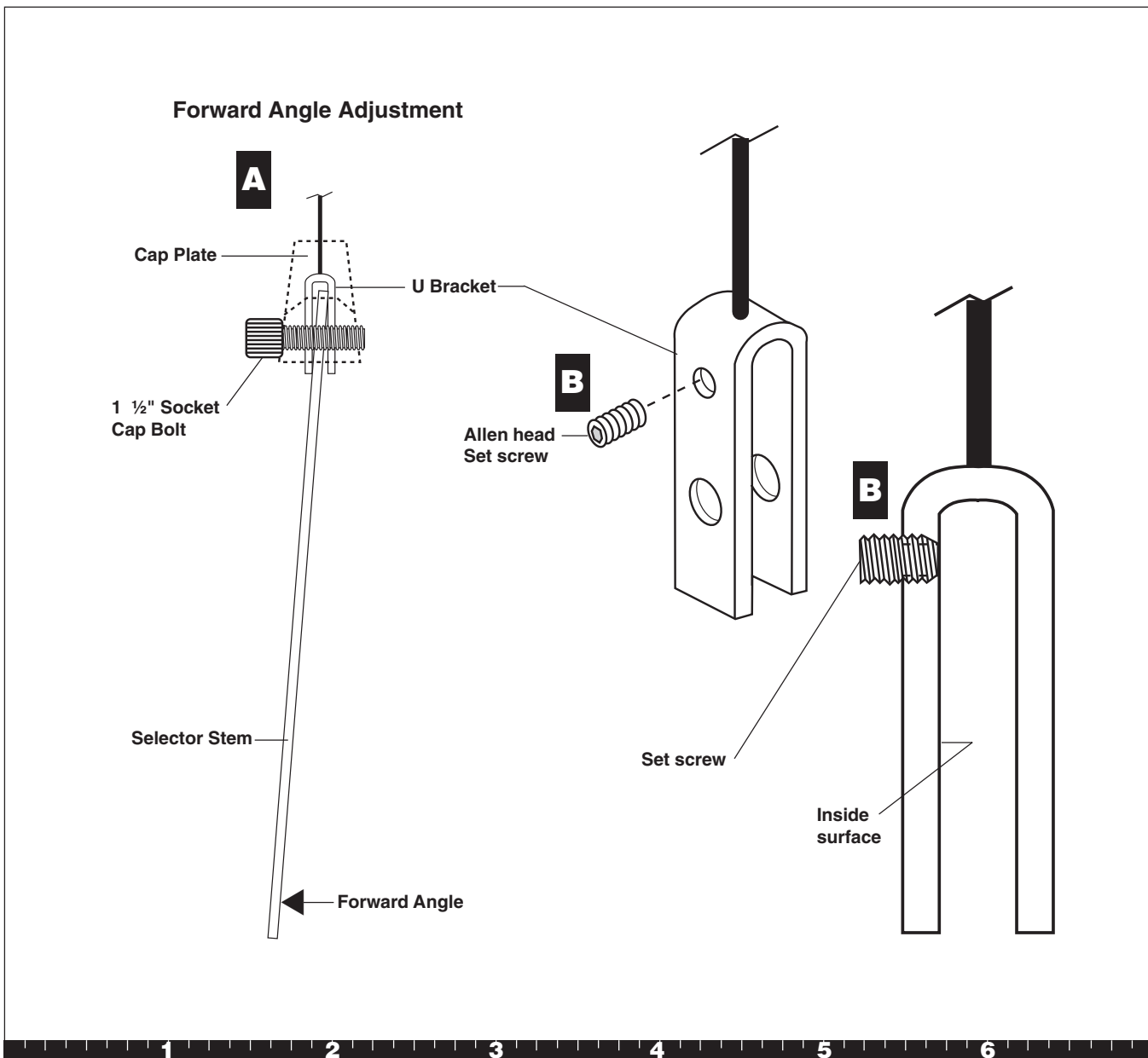

Step 2. Selector Stem Adjustments

- D. Reassemble the Cap Plate, Selector Stem, and Cable Clamp.
- E. Test the movement of the Selector Stem inside the Weight Stack.
- F. If the Selector Stem continues to contact the plates, repeat steps A through E until the Selector Stem slides through the Weight Stack without contacting the plates.

Backward Angle Adjustment

When the Selector Stem angles backward (away from the seat) and contacts the inside of the Weight Stack during use, adjust it by taking these steps:

Caution: This adjustment requires two people.

- A. Completely disassemble the Cap Plate, Selector Stem, and Cable Clamp.
- B. Thread Allen head set screw into the hole closest to the top of the U end of the Cable and turn clockwise until the end of the screw is flush with the inside surface of the clamp.
- C. Turn the set screw clockwise another one-half turn (see diagram).
- D. Reassemble the Cap Plate, Selector Stem, and Cable Clamp.
- E. Test the movement of the Selector Stem inside the Weight Stack.
- F. If the Selector Stem continues to contact the plates, repeat steps A through E until the Selector Stem slides through the Weight Stack without contacting the plates.

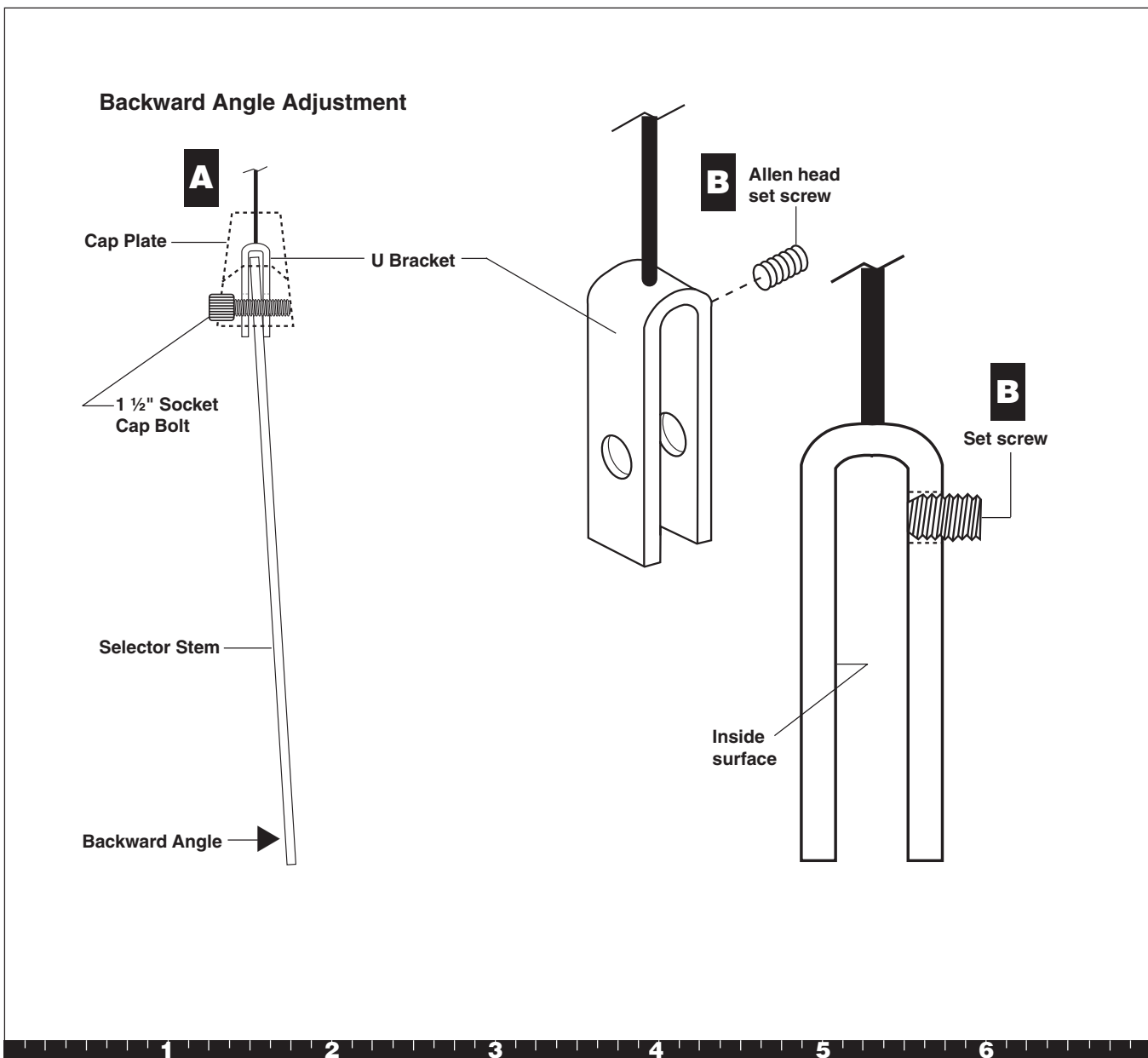

Step 2. Selector Stem Adjustments, Continued

Side-to-Side Vertical Adjustment

If the Selector Stem contacts the inside of the Weight Stack during use or the Weight Pin becomes difficult to insert in the Weight Stack, the Selector Stem may be out of alignment vertically side to side. Adjust the Selector Stem by taking these steps:

Caution: Performing these steps requires two people.

- A. Pull the Selector Stem and Top Cap up to expose at least five Selector Stem holes.
- B. Insert the Weight Pin near the base of the Selector Stem to hold it in place.
- C. To center the Selector Stem, loosen the socket cap bolt that attaches the Top Cap to the U bracket.
- D. Once the Selector Stem is centered, retighten the socket cap bolt securely.
- E. Lower the Selector Stem into the Weight Stack. Test the movement of the Selector Stem inside the Weight Stack.
- F. Make certain that the Weight Pin can be inserted into every hole in the Weight Stack. If the Selector Stem continues to contact the plates, repeat steps A through E until the Selector Stem slides through the Weight Stack without contacting the plates.

After completing the adjustments, fill out the warranty card and mail it in.

3. Maintenance

Lubricate the Guide Rods every six months.

Thank you for choosing Precor!

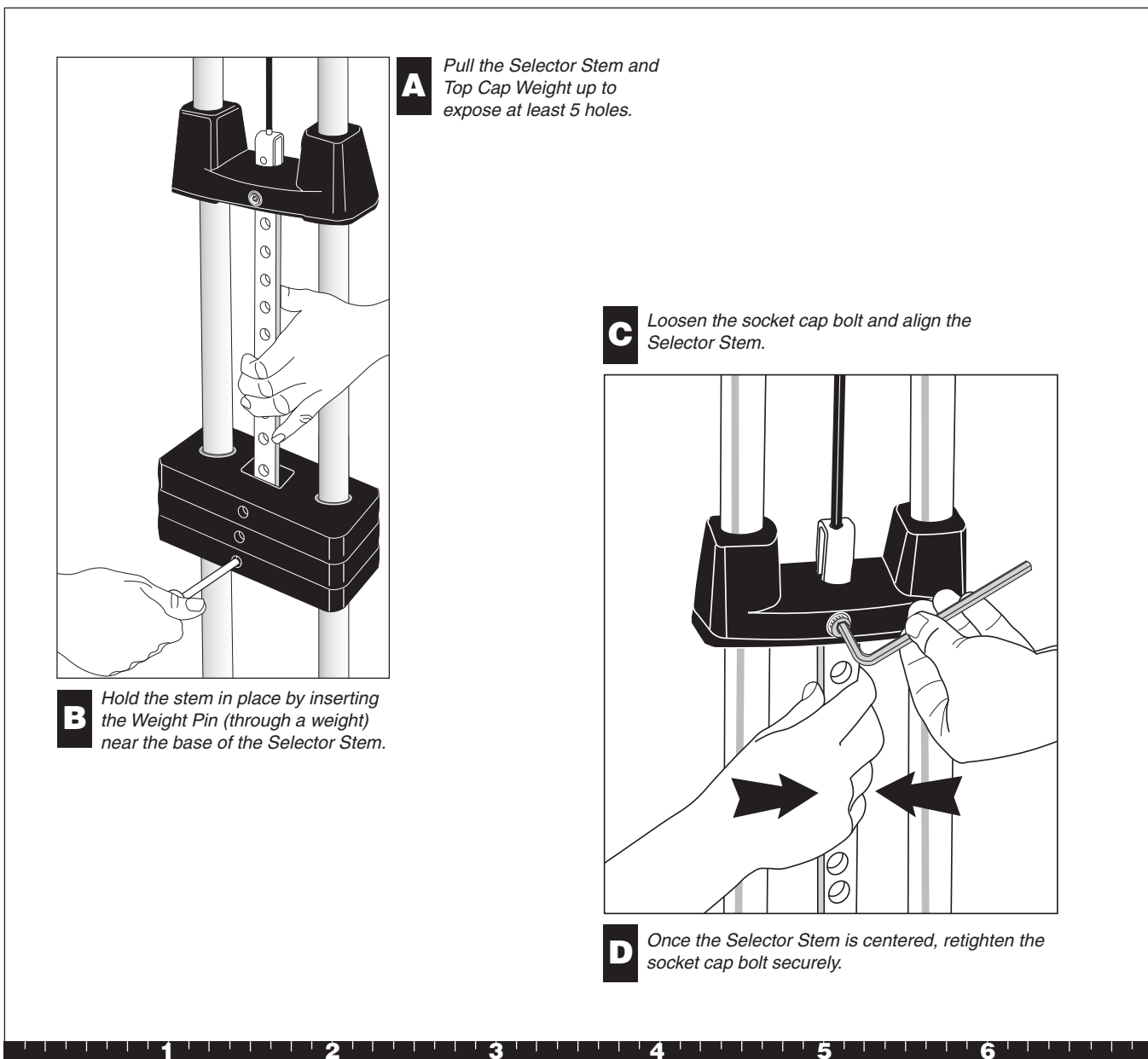

Step 3. Maintenance

Thank You and Welcome to Precor



To allow us to serve you better, please take a few moments to complete and return your warranty registration.

YOU MAY ALSO REGISTER ONLINE AT

www.precor.com/warranty

If you have questions or need additional information, contact your local dealer or call Precor Customer Support at 800-347-4404.

RET.

PRECOR 
Precor Incorporated
20031 142nd Avenue NE
PO Box 7202
Woodinville, WA 98072-4002

PLACE
STAMP
HERE

TELL US ABOUT YOUR NEW PRECOR PRODUCT

Date of Purchase: _____
 Month Day Year

Purchased from: _____
 Dealer Name

Product Serial Number: _____
The serial number is located on the shipping box and on the product.

Please indicate the type of product purchased:

- Elliptical Fitness Cross Trainer (EFFX®)
- Treadmill
- Strength Training System
- StretchTrainer™
- Cycle
- Stair Climber

TELL US ABOUT YOU

Mr. Mrs. Ms.

First Name

Middle Initial

Last Name

Street Address

Apt./Suite:

City

State

Zip Code

Area Code

Telephone

Your Email Address

Gender: Male Female

Marital status: Married Divorced Widowed Never been married

Age: Under 18 18-24 25-34 35-44 45-54 55-64 65+

Annual household income: Under \$50,000 \$51,000-75,000 \$76,000-100,000 \$101,000-150,000 \$151,000+

What are your fitness goals? Weight loss/management Muscle tone enhancement Cardiovascular improvement Overall health Increase energy and flexibility Stress reduction Rehabilitation Other

TELL US ABOUT YOUR PURCHASE

Purchase (check all that apply):

- First Precor product
- Replaces a Precor product of the same type
- Replaces same type of product – different brand
- Addition to equipment currently owned

How did you FIRST become aware of Precor products (choose only one):

- A gift
- Friend/relative
- Physician
- Fitness club
- Internet
- News report or product review
- Magazine advertisement or article
- Print advertisement
- In-store display or demonstration
- Other

What factors MOST influenced your decision to purchase your Precor product (choose up to three):

- Precor reputation
- Prior use of Precor product(s)
- Design/appearance
- Value for the price
- Special product features
- Rebate or sale price
- Quality/durability
- Warranty
- Physician recommendation

Precor Residential Equipment Limited Warranty

PLEASE READ THESE WARRANTY TERMS AND CONDITIONS CAREFULLY BEFORE USING YOUR PRECOR INCORPORATED PRODUCT. BY USING THE EQUIPMENT, YOU ARE CONSENTING TO BE BOUND BY THE FOLLOWING WARRANTY TERMS AND CONDITIONS.

Limited Warranty.

Precor Incorporated warrants all new Precor products to be free from defects in materials and manufacture for the warranty period set forth below. The warranty period commences on the invoice date of original purchase. This warranty applies only against defects discovered within the warranty period and extends only to the original purchaser of the product. Parts repaired or replaced under the terms of this warranty will be warranted for the remainder of the original warranty period only. To make claim under warranty, the buyer must notify Precor or their authorized Precor dealer within 30 days after the date of discovery of any nonconformity and make the affected product available for inspection by Precor or its service representative. Precor's obligations under this warranty are limited and set forth below.

Warranty Periods and Coverage

All residential products and commercial products used in the home are warranted for the following periods:

- Lifetime frame and welds
- 10 years parts and wear items
- 1 year labor
- Coverage for options and accessories defined below.

Options / Accessories

Many options or accessories have components that are connected internally or mounted inside the electronic console. The following guidelines determine the warranty for these components. If the internal components are installed by the factory or by an authorized dealer as part of the original sale and delivery, they have a warranty that is identical to the warranty of the equipment in which they are connected or mounted. If the internal components are not installed by the factory or by an authorized dealer as part of the original sale and delivery, they have a 90-day parts and labor limited warranty. All components that are not internally connected have 90-day parts only limited warranty. Satisfactory proof of purchase is required in all cases.

Conditions and Restrictions

This warranty is valid only in accordance with the conditions set forth below:

1. The warranty applies to the Precor product only while:
 - a. It remains in the possession of the original purchaser and proof of purchase is demonstrated
 - b. It has not been subjected to accident, misuse, abuse, improper service, or non-Precor modifications
 - c. Claims are made within the warranty period
2. This warranty does not cover damage or equipment failure caused by electrical wiring not in compliance with electrical codes or Precor owner's manual specifications, or failure to provide reasonable and necessary maintenance as outlined in the owner's manual.

Complete this portion and keep for your records.

Purchased From: _____ Example: Dealer or store name.
Phone Number: _____ Example: Dealer or store telephone number.
Product/model: _____ Example: M9.31
Serial number: _____ The serial number is found on the shipping container

3. Warranty of all Precor products applies to residential use only and is void when products are used in a nonresidential environment or installed in a country other than where sold.
4. Except in Canada, Precor does not pay labor outside the United States.
5. Warranties outside the United States and Canada may vary. Please contact your local Dealer for details.

This limited warranty shall not apply to:

1. Software version upgrades
2. Cosmetic items, including, but not limited to the following: grips, seats, and labels.
3. Repairs performed on Precor equipment missing a serial number or with a serial tag that has been altered or defaced.
4. Service calls to correct installation of the equipment or instruct owners on how to use the equipment.
5. Pickup, delivery, or freight charges involved with repairs.
6. Any labor costs incurred beyond the applicable labor warranty period.

Disclaimer and Release

The warranties provided herein are the exclusive warranties given by Precor and supersede any prior, contrary or additional representations, whether oral or written. ANY IMPLIED WARRANTIES, INCLUDING THE WARRANTY OF MERCHANTABILITY OR FITNESS FOR A PARTICULAR PURPOSE THAT APPLY TO ANY PARTS DESCRIBED ABOVE ARE LIMITED IN DURATION TO THE PERIODS OF EXPRESS WARRANTIES GIVEN ABOVE FOR THOSE SAME PARTS. PRECOR HEREBY DISCLAIMS AND EXCLUDES THOSE WARRANTIES THEREAFTER. Some states do not allow limitation on how long an implied warranty lasts, so the above limitation may not apply to you. PRECOR ALSO HEREBY DISCLAIMS AND EXCLUDES ALL OTHER OBLIGATIONS OR LIABILITIES, EXPRESS OR IMPLIED, ARISING BY LAW OR OTHERWISE, WITH RESPECT TO ANY NONCONFORMANCE OR DEFECT IN ANY PRODUCT, INCLUDING BUT NOT LIMITED TO: (A) ANY OBLIGATION, LIABILITY, RIGHT, CLAIM OR REMEDY IN TORT, WHETHER OR NOT ARISING FROM THE NEGLIGENCE OF PRECOR OR ITS SUPPLIERS (WHETHER ACTIVE, PASSIVE OR IMPUTED); AND (B) ANY OBLIGATION, LIABILITY, RIGHT, CLAIM, OR REMEDY FOR LOSS OF OR DAMAGE TO ANY EQUIPMENT. This disclaimer and release shall apply even if the express warranty set forth above fails of its essential purpose.

Exclusive Remedies

For any product described above that fails to conform to its warranty, Precor will provide, at their option, one of the following: (1) repair; (2) replacement; or (3) refund of the purchase price. Precor Limited Warranty service may be obtained by contacting the authorized dealer from whom you purchased the item. Precor compensates Servicers for warranty trips within their normal service area to repair equipment at the owner's location. You may be charged a trip charge outside the service area. THESE SHALL BE THE SOLE AND EXCLUSIVE REMEDIES OF THE BUYER FOR ANY BREACH OF WARRANTY.

Exclusion of Consequential and Incidental Damages

PRECOR AND/OR ITS SUPPLIERS SHALL HAVE NO OBLIGATION OR LIABILITY, WHETHER ARISING IN CONTRACT (INCLUDING WARRANTY), TORT (INCLUDING ACTIVE, PASSIVE, OR IMPUTED NEGLIGENCE AND STRICT LIABILITY), OR OTHERWISE, FOR DAMAGE TO THE EQUIPMENT, PROPERTY DAMAGE, LOSS OF USE, REVENUE OR PROFIT, COST OF CAPITAL, COST OF SUBSTITUTE EQUIPMENT, ADDITIONAL COST INCURRED BY BUYER (BY WAY OF CORRECTION OR OTHERWISE) OR ANY OTHER INCIDENTAL, SPECIAL, INDIRECT, OR CONSEQUENTIAL DAMAGES, WHETHER RESULTING FROM NONDELIVERY OR FROM THE USE, MISUSE OR INABILITY TO USE THE PRODUCT. This exclusion applies even if the above warranty fails of its essential purpose and regardless of whether such damages are sought for breach of warranty, breach of contract, negligence, or strict liability in tort or under any other legal theory. Some states do not allow the exclusion or limitation of incidental or consequential damages, so the above limitation might not apply.

This warranty gives you specific legal rights, and you may also have other rights, which vary state to state.

S3.25 Specifications

Length: 66 inches (168 cm)

Height: 82 inches (208 cm)

Width: 48 inches (122 cm) Leg press option adds 15 inches (38 cm)

Shipping weight: 339 lb (154 kg)



Precor Incorporated
20031 142nd Avenue NE
P.O. Box 7202
Woodinville, WA USA 98072-4002

Precor and Pacific Fitness are registered trademarks of Precor Incorporated.
Specifications subject to change without notice.
Copyright 2006 Precor Incorporated.
Precor web site: www.precor.com

NOTICE:

Precor is widely recognized for its innovative, award winning designs of exercise equipment. Precor aggressively seeks U.S. and foreign patents for both the mechanical construction and the visual aspects of its product design. Any party contemplating the use of Precor's product designs is hereby forewarned that Precor considers the unauthorized appropriation of its proprietary rights to be a very serious matter. Precor will vigorously pursue all unauthorized appropriation of its proprietary rights.

S3.25 Literature Kit # 47941-104
Owner's Manual # 47996-104
Warranty Registration # 45623-102
Warranty Card # 36287-110
Effective date: 01 May, 2006