

**Upright Pro Bike  
Recumbent Pro Bike**

---

**OWNER'S MANUAL**

Copyright 2000. Star Trac by Unisen, Inc. All rights reserved, including those to reproduce this book or parts thereof in any form without first obtaining written permission from Star Trac.

Every effort has been made to keep this information current; however, periodically, changes are made to the information herein, and these changes will be incorporated into new editions of this publication. All product names and logos are trademarks of their respective owners. Printed in the USA.

# TABLE OF CONTENTS

|          |   |           |
|----------|---|-----------|
| <b>1</b> | <b>INTRODUCTION</b>                         | <b>1</b>  |
|          | About this Manual .....                     | 1         |
| <b>2</b> | <b>SAFETY INSTRUCTIONS</b>                  | <b>3</b>  |
|          | Precautions .....                           | 4         |
|          | Veiligheidsinstructies .....                | 5         |
|          | Consignes de Sécurité .....                 | 6         |
|          | Sicherheitsvorschriften .....               | 7         |
|          | Istruzioni di Sicurezza .....               | 8         |
|          | Instruções de Segurança .....               | 9         |
|          | Instrucciones de Seguridad .....            | 10        |
|          | Sikkerhedsinstruktioner .....               | 11        |
| <b>3</b> | <b>ASSEMBLY AND SETUP</b>                   | <b>13</b> |
|          | Unpacking .....                             | 13        |
|          | Assembly .....                              | 13        |
| <b>4</b> | <b>OPERATING INSTRUCTIONS</b>               | <b>15</b> |
|          | Sport Utility Display .....                 | 15        |
|          | Getting Started .....                       | 20        |
|          | Heart Rate Training Programs .....          | 23        |
|          | FitLinxx .....                              | 25        |
| <b>5</b> | <b>PERSONAL TRAINING STUDIO™</b>            | <b>27</b> |
|          | Assigning Personal Trainer PIN Codes .....  | 27        |
|          | Using the Personal Training Studio .....    | 28        |
| <b>6</b> | <b>PREVENTATIVE MAINTENANCE</b>             | <b>31</b> |
|          | Daily Maintenance .....                     | 31        |
|          | Weekly Maintenance .....                    | 31        |
|          | Monthly Maintenance .....                   | 31        |
| <b>7</b> | <b>DISPLAY SETTINGS</b>                     | <b>33</b> |
|          | Display Setting Parameters .....            | 33        |
|          | Entering Display Settings Mode .....        | 34        |
|          | Viewing and Changing Display Settings ..... | 34        |
| <b>8</b> | <b>TROUBLESHOOTING</b>                      | <b>35</b> |
|          | Start-Up Service Messages .....             | 35        |

|  |           |
|--|-----------|
| <b>9 REGULATORY INFORMATION</b>          | <b>37</b> |
| FCC and Other Domestic Regulations ..... | 37        |
| Canadian DOC and Other Regulations ..... | 38        |
| European Applications.....               | 38        |

---

# 1

## INTRODUCTION

Thank you for choosing a Star Trac Pro Bike—the world’s most innovative stationary bike. Available as an upright bike or a recumbent bike, the Pro Bike combines innovative technology, ease of use, and total reliability for a real bicycle feel. Through its revolutionary design, the Pro Bike offers several challenging, motivational workouts that recruit a variety of muscle groups.

### ABOUT THIS MANUAL

This manual is applicable to the Star Trac Upright Pro Bike and Recumbent Pro Bike, and is divided into the following sections:

- 1 Introduction**  
Provides an overview of each section within the manual.
- 2 Safety Instructions**  
Includes guidelines in multiple languages for safely operating Star Trac Pro Bikes.
- 3 Assembly and Setup**  
Provides instructions for unpacking, assembling and setting up Star Trac Pro Bikes.
- 4 Operating Instructions**  
Includes a detailed description of the Sport Utility Display and step-by-step instructions for operating Star Trac Pro Bikes.
- 5 Personal Training Studio**  
Enables you to set up and administer personal trainer PIN codes, which can be used to design and save custom cycling cross-training programs.
- 6 Preventative Maintenance**  
Describes the preventative maintenance measures required to keep Star Trac Pro Bikes in top condition.
- 7 Display Settings**  
Provides step-by-step instructions for changing universal parameters on Star Trac Pro Bikes.
- 8 Troubleshooting**  
Describes the start-up and shutdown messages provided as a result of the self-test routine.
- 9 Regulatory Information**  
Provides regulatory information for Star Trac Pro Bikes.

# Star Trac Pro Bikes

---

## OWNER'S MANUAL



CAUTION: Read this owner's manual completely before operating your Star Trac Pro Bike.



CAUTION: Moving parts. Do not drop or insert any object, hands or feet into any openings or moving parts of the equipment.

---

# 2

## SAFETY INSTRUCTIONS

This chapter includes fitness safeguards and precautions for the installation and use of Star Trac Pro Bikes. Please read this chapter carefully before installing or using your equipment.

Safety instructions are provided in the following languages (in the order shown):

- English
- Dutch
- French
- German
- Italian
- Portuguese
- Spanish
- Swedish

## OWNER'S MANUAL

### PRECAUTIONS

These safety notes are directed to you as the owner of the Star Trac Pro Bike. Please train all your members and fitness staff to follow these safety instructions.

#### Do

- Do encourage each of your members to discuss their health program or fitness regimen with a healthcare professional, especially if the member has not exercised for several years, is over 35 years of age, or is overweight.
- Do stop operating your Pro Bike if you feel dizzy or faint.
- Do perform regular preventative maintenance.
- Do exercise slowly until you reach a level of comfort.
- Do use the Pro Bike only for its intended use, as described in this manual.

#### Do Not

- Do not let unsupervised children operate your Pro Bike.
- Do not use without athletic shoes.
- Do not use in rainy weather outdoors, or in an enclosed pool environment.
- Do not drop or insert any object, hands, or feet into any opening, or underneath your Pro Bike.
- Do not attempt to remove any shrouds or modify your Pro Bike.

### WARNING

Your Star Trac Pro Bike is designed for aerobic exercise in a commercial or consumer environment.

Please check with your physician prior to beginning any exercise program.

Do not push yourself to excess. Stop if you are feeling faint, dizzy, or exhausted. Use common sense when cycling.

Read the Owner's Manual in its entirety before operating your cycle.

Failure to obey this warning can result in injury or death.

### VEILIGHEIDSINSTRUCTIES

Deze veiligheidsinstructies zijn aan u gericht als de eigenaar van de Star Trac Pro Bikes. Train uw leden en fitness-personeel om dezelfde veiligheidsinstructies te volgen.

#### Doe Dit Wel

- Moedig uw leden aan om hun gezondheids- of fitnessprogramma met een geneeskundige te bespreken, vooral als ze jarenlang niet getraind hebben, ouder dan 35 zijn of te zwaar zijn.
- Stop met de fiets als u zich duizelig voelt of het gevoel heeft dat u flauwvalt.
- Verricht regelmatig preventief onderhoud.
- Begin langzaam totdat u een comfortabel en veilig niveau heeft bereikt.
- Gebruik het apparaat alleen voor het doel waarvoor het bestemd is en zoals in dit handboek beschreven.

#### Doe Dit Niet

- Laat kinderen niet zonder toezicht de fiets bedienen.
- Plaats uw voeten niet onder uw fiets.
- Gebruik de fiets niet zonder sportschoenen.
- Niet buiten in regenachtig weer gebruiken of in een omgeving met een overdekt zwembad.
- Laat nooit objecten in het apparaat vallen en steek geen objecten, handen of voeten in welke opening dan ook of onder het apparaat.
- Verwijder nooit afschermingen en verander het apparaat niet.

### WAARSCHUWING

Uw Star Trac Pro Bike is ontworpen voor aerobics in een commerciële of consumentenomgeving.

Vraag advies aan uw arts voordat u met een fitnessprogramma begint.

Vraag niet teveel van uzelf. Stop als u het gevoel heeft dat u flauw gaat vallen, als u duizelig bent of uitgeput. Gebruik uw gezonde verstand bij het stappen. Lees de gebruikshandleiding helemaal door voordat u uw fiets gebruikt.

### CONSIGNES DE SÉCURITÉ

Ces consignes de sécurité sont destinées au propriétaire du Vélo d'exercice Star Trac. Veuillez enseigner ces consignes à tous vos membres et employés.

#### À Faire

- Encouragez vos membres à discuter de leur programme de santé ou d'exercice avec un médecin, particulièrement s'ils n'ont pas fait d'exercice depuis plusieurs années, s'ils sont âgés de plus de 35 ans ou s'ils ont un excès de poids.
- Arrêtez tout exercice sur le vélo si vous éprouvez un étourdissement ou une défaillance.
- Effectuez régulièrement un entretien préventif.
- Exercez-vous lentement jusqu'à ce que vous vous sentiez à l'aise et en sécurité.
- N'utilisez cet appareil que dans le but pour lequel il est conçu.

#### À Ne Pas Faire

- Ne laissez pas des enfants utiliser le vélo sans surveillance.
- Ne placez pas vos pieds sous le vélo.
- Ne permettez à personne de s'exercer sans chaussures athlétiques.
- N'utilisez pas l'appareil à l'extérieur par temps pluvieux ou à proximité d'une piscine.
- N'insérez jamais la main, le pied ou un objet dans les ouvertures de l'appareil, ni sous l'appareil.
- Ne modifiez jamais cet appareil et ne retirez aucun de ses éléments protecteurs.

### MISE EN GARDE

Votre Vélo Star Trac est conçu pour l'exercice d'aérobic dans un contexte commercial ou à la maison.

Veuillez consulter votre médecin avant d'entreprendre tout programme d'exercice.

Évitez tout exercice excessif. Arrêtez si vous éprouvez un étourdissement, une défaillance ou de la fatigue. Fiez-vous à votre bon sens. Lisez attentivement la notice d'utilisation dans son intégralité avant d'utiliser votre vélo.

### SICHERHEITSVORSCHRIFTEN

Diese Sicherheitshinweise sind an Sie, den Besitzer des Fitness-Bikes von Star Trac gerichtet. Bitte weisen Sie Ihre Mitglieder und Mitarbeiter an, sich an die folgenden Sicherheitsvorschriften zu halten.

#### Sie Sollten

- Ihren Mitgliedern nahelegen, ihr Gesundheitsprogramm oder Fitneß-Training mit einem Arzt zu besprechen, vor allem, wenn Sie seit mehreren Jahren nicht mehr trainiert haben, über 35 Jahre alt oder übergewichtig sind.
- Die Benutzung des Fitneß-Bikes beenden, wenn Benommenheit oder Schwindel auftritt.
- Das Gerät regelmäßig warten.
- Langsam trainieren, bis Sie sicher mit dem Gerät umgehen können.
- Dieses Gerät nur für den vorgesehenen Zweck gemäß der Beschreibung in diesem Handbuch verwenden.

#### Sie Sollten Niemals

- Kinder das Fitneß-Bike unbeaufsichtigt benutzen lassen.
- Die Füße unter das Fitneß-Bike stellen.
- Die Benutzung des Fitneß-Bikes ohne die passenden Sportschuhe zulassen.
- Das Gerät bei Regenwetter im Freien oder in einem Hallen-bzw. überdachten Schwimmbad verwenden.
- Gegenstände in eine Öffnung des Geräts stecken oder darunter fallen lassen oder Hände bzw. Füße unter das Gerät halten.
- Abdeckungen abnehmen oder das Gerät ändern.

### WARNUNG

Das Fitness-Bike von Star Trac ist für das Aerobik-Training in einem kommerziellen oder Verbraucherumfeld vorgesehen.

Bitte konsultieren Sie Ihren Arzt, bevor Sie mit einem Trainingsprogramm beginnen.

Überanstrengen Sie sich nicht. Hören Sie auf, wenn Schwindel, Benommenheit oder Erschöpfung eintreten. Gehen Sie beim Training vernünftig vor. Lesen Sie bitte das Benutzerhandbuch vor Verwendung des Fitneß-Bikes vollständig durch.

### ISTRUZIONI DI SICUREZZA

Queste indicazioni sono indirizzate ai proprietari dello Star Trac cyclette. Chiedete a tutti i membri della vostra palestra e al vostro staff di seguire queste istruzioni di sicurezza.

#### Da Fare

- Incoraggiate i membri della vostra palestra a discutere il loro programma o regime di allenamento con uno specialista medico, soprattutto se non si sono allenati da qualche anno, se hanno più di 35 anni o se sono in sovrappeso.
- Fermate lo cyclette se avete dei capogiri o vi sentite svenire.
- Eseguite la manutenzione regolarmente.
- Esercitatevi lentamente fino a quando raggiungete un livello confortevole e sicuro.
- Usate questo attrezzo solo per l'uso inteso, come descritto in questo manuale.

#### Da Non Fare

- Non permettete a bambini di usare lo cyclette senza sorveglianza.
- Non inserite i piedi sotto lo cyclette.
- Non usate lo cyclette se non calzate scarpe da ginnastica.
- Non usatelo all'aperto quando piove o vicino ad una piscina coperta.
- Non lasciate cadere oggetti e non inserite mani o piedi nelle aperture o al di sotto di questo attrezzo.
- Non rimuovete nessun coperchio o modificate questo attrezzo.

### ATTENZIONE

Lo Star Trac Cyclette è stato progettato per l'esercizio aerobico in un ambiente commerciale o domestico.

Consultatevi con il vostro medico di famiglia prima di intraprendere un programma di esercizi.

Siate coscienti dei vostri limiti. Fermatevi se avete dei capogiri, vi sentite svenire o siete esausti. Usate il vostro buon senso quando usate lo cyclette. Leggete tutto il manuale delle istruzioni prima di usare lo cyclette.

### INSTRUÇÕES DE SEGURANÇA

Estas observações de segurança destinam-se à você, proprietário da bicicleta Star Trac. Treine todos os membros e funcionários que utilizarão o equipamento para que sigam estas instruções de segurança.

#### Faça

- Estimule seus usuários para que discutam seus programas de saúde ou de exercícios com um profissional de saúde, principalmente se eles não tiverem feito exercícios por vários anos, possuírem mais de 35 anos ou forem obesos.
- Pare de usar a bicicleta se você se sentir fraco ou com tontura.
- Faça manutenção preventiva regularmente.
- Faça o exercício lentamente até que você alcance um nível de conforto e segurança.
- Utilize este equipamento única e exclusivamente para o seu devido fim, conforme descrito neste manual.

#### Não Faça

- Não permita que crianças operem a bicicleta sem supervisão de um adulto.
- Não coloque seus pés embaixo da bicicleta.
- Não utilize a bicicleta sem calçar tênis.
- Não use este equipamento ao ar livre, em dias chuvosos ou em um ambiente de piscina interna.
- Nunca deixe cair ou introduza nenhum objeto, as mãos ou pés em nenhuma abertura do equipamento ou debaixo deste.
- Não remova nenhum protetor ou modifique este equipamento.

### ADVERTÊNCIA

A sua bicicleta Star Trac foi projetada para exercício aeróbico em um ambiente comercial ou residencial.

Faça um exame físico com seu médico antes de iniciar qualquer programa de exercícios.

Não abuse. Para se estiver sentindo tontura, fraqueza ou exaustão. Use bom senso quando se exercitar. Leia o manual do proprietário por completo antes de operar a sua bicicleta.

## **INSTRUCCIONES DE SEGURIDAD**

Estas notas de seguridad van dirigidas a Vd. como propietario del bicicleta Star Trac. Haga que todos los usuarios y preparadores físicos cumplan estas instrucciones de seguridad.

### **Qué Hacer**

- Anime a sus miembros a que discutan su programa de salud o régimen de ejercicio con un profesional de la salud, especialmente si no han hecho ejercicio por varios años, tienen más de 35 años de edad o pesan demasiado.
- Detenga el escalón si se nota desfallecido o mareado.
- Realice un mantenimiento preventivo de manera regular.
- Haga ejercicio despacio hasta alcanzar un nivel de comodidad y seguridad.
- Utilice este producto sólo para los usos indicados, tal como se describe en este manual.

### **Qué No Hacer**

- No permita que los niños utilicen el bicicleta sin supervisión.
- No ponga los pies debajo del bicicleta.
- No permita su uso sin calzado deportivo.
- No lo utilice en el exterior con tiempo lluvioso o en un recinto cerrado con piscina.
- No deje caer ni introduzca ningún objeto, manos o pies en ninguna abertura del aparato o debajo del mismo.
- No quite ninguna cubierta ni modifique este equipo.

## **ADVERTENCIA**

Su bicicleta Star Trac está diseñado para realizar ejercicio aeróbico en un entorno comercial o en forma individual.

Consulte a su médico antes de empezar cualquier programa de ejercicio.

No se exceda. Interrumpa el ejercicio si se nota desfallecido, mareado o agotado. Utilice el sentido común al usar este aparato. Lea el manual del propietario en su totalidad antes de poner en marcha el escalón.

### SIKKERHEDSINSTRUKTIONER

Disse sikkerhedsinstruktioner henvendes til ejeren af Star Trac cykel. Sørg venligst for, at alle medlemmer og alt kondipersonale kender og følger disse sikkerhedsregler.

#### Råd

- Medlemmer bør opfordres til at tale om deres helseprogram eller kondiregime med en læge, især hvis de ikke har drevet kondi i flere år, er over 35, eller er overvægtige.
- Stig af cyklen, hvis du bliver mat i kroppen eller svimmel.
- Foretag forebyggende vedligeholdelse med regelmæssige mellemrum.
- Gør øvelserne langsomt, indtil du når et behageligt og sikkert niveau.
- Udstyret bør udelukkende bruges til det formål, det er beregnet til ifølge denne brugsanvisning.

#### Advarsler

- Tillad ikke børn uden opsyn at bruge cyklen.
- Sæt ikke fødderne under cyklen.
- Brug ikke cyklen uden kondisko.
- Brug ikke cyklen udendørs i regnvejrs eller i et indelukket område med svømmebassin.
- Undgå at tabe eller at stikke genstande, hænder eller fødder ind i en åbning i eller under udstyret.
- Undlad at fjerne afskærmning eller forandre udstyret på nogen måde.

### ADVARSEL

Din Star Trac cykel er konstrueret til konditræning i et erhvervseller forbrugermiljø.

Vær venlig at rådføre dig med din læge, før du påbegynder et kondiprogram.

Du må ikke overanstrenge dig alt for meget. Stop hvis du føler dig mat i kroppen, svimmel eller udmattet. Brug sund fornuft, når du cykler. Vær venlig at læse hele brugsanvisningen, før du stiger på cyklen.

## Star Trac Pro Bikes

---

### OWNER'S MANUAL

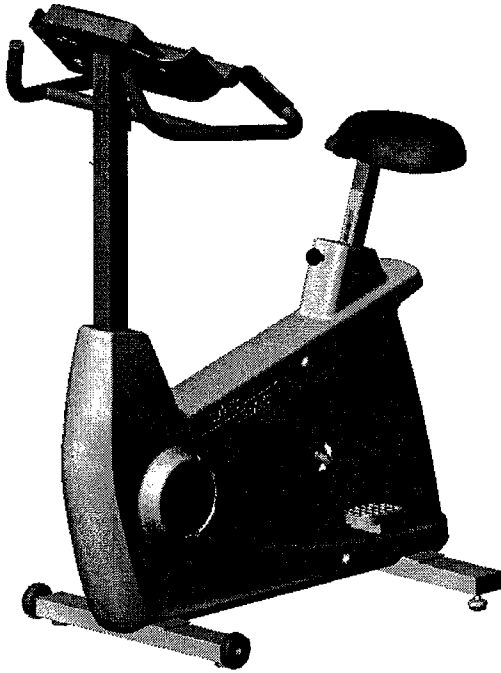

Star Trac Upright Pro Bike

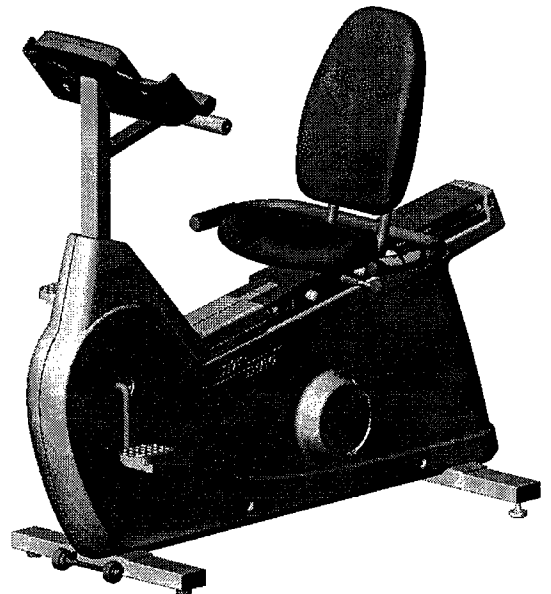

Star Trac Recumbent Pro Bike

# 3

## ASSEMBLY AND SETUP

Your Star Trac Pro Bike comes completely assembled. You will need to adjust the feet of the Pro Bike for uneven surfaces, and raise or lower the seat to suit your height. Detailed instructions for unpacking and setting up your new Pro Bike are provided in this chapter.

### UNPACKING

1. Remove all parts from the crate.
2. Verify that the following parts have been included in your shipment:

| DESCRIPTION   | QUANTITY |
|---|----------|
| Star Trac Pro Bike                                      | 1        |
| 9/16" x 7/8" Combo Wrench                               | 1        |
| 1/8" Hex Key  | 1        |
| Pro Bike Owner's Manual with Warranty Registration Card | 1        |

3. Immediately report any missing components to Star Trac Product Support at (800) 503-1221 or (714) 669-1660. Please be ready to provide both the serial number and model number of your Star Trac Pro Bike.

### ASSEMBLY

#### Leveling the Unit

If necessary, level your Pro Bike using the two adjustable pads located on the bottom rear of the Pro Bike. Unlock the lock nuts using the Combo Wrench, raise or lower the adjustable pad as needed, and retighten the lock nut against the frame.

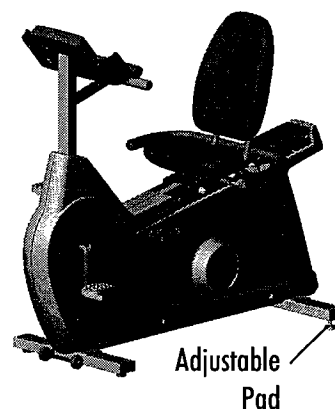

## OWNER'S MANUAL

### Adjusting the Seat on the Upright Pro Bike

When sitting on the seat of your Upright Pro Bike, your knees should be almost fully extended when the pedals are in the lowest point in their rotation. To adjust the seat:

Stand on the pedal at the lowest point with your knee slightly bent. Carefully pull forward on the seat adjustment knob located under the seat, and move the seat to the closest available position that supports your height. Release the knob, ensuring that the spring retracts to its original position and that the seat stays firmly in place.

Note your height adjustment number for future reference. This number is the highest number visible on the seat post located just above the knob.

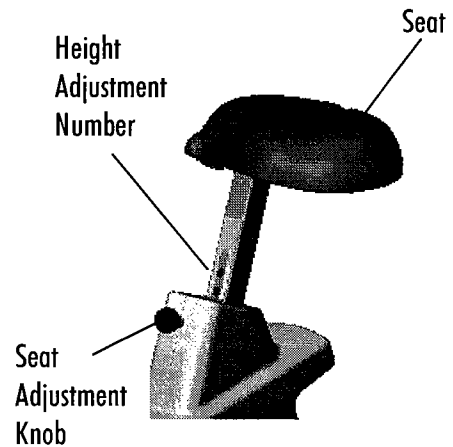

### Adjusting the Seat on the Recumbent Pro Bike

When sitting on the seat of your Recumbent Pro Bike, your knees should be almost fully extended when the pedals are in the lowest point in their rotation. To adjust the seat:

Sit on the seat and grasp the seat adjustment knob located under the lower left side of the seat. Pull the knob outward and move the seat to the closest available position that allows your knees to be slightly bent toward the lower pedal. Release the knob, ensuring that the spring retracts to its original position and that the seat stays firmly in place.

Note your position adjustment number for future reference. This number is the highest number visible on the seat track just in front of the seat.

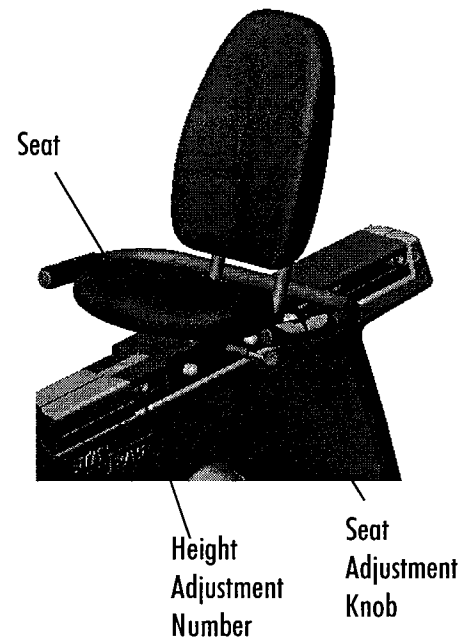

# 4

## OPERATING INSTRUCTIONS

Star Trac Pro Bikes are equipped with an easy-to-use sport utility display. The display features:

- International symbols to ensure easy operation
- One-button start and change of resistance
- Fluorescent graphical digital display that provides instant feedback in large, easy-to-read letters
- Integrated holders for a water bottle, personal stereo, reading materials and a towel.

This chapter describes the display in detail and provides step-by-step instructions for operating your Pro Bike.

### SPORT UTILITY DISPLAY

The Sport Utility Display of your Star Trac Pro Bike is used to operate the unit and includes an integrated reading rack, water bottle holder, personal stereo holder and towel holder to accommodate all of your needs. Each of the components of the display are shown below and described in detail in this section.

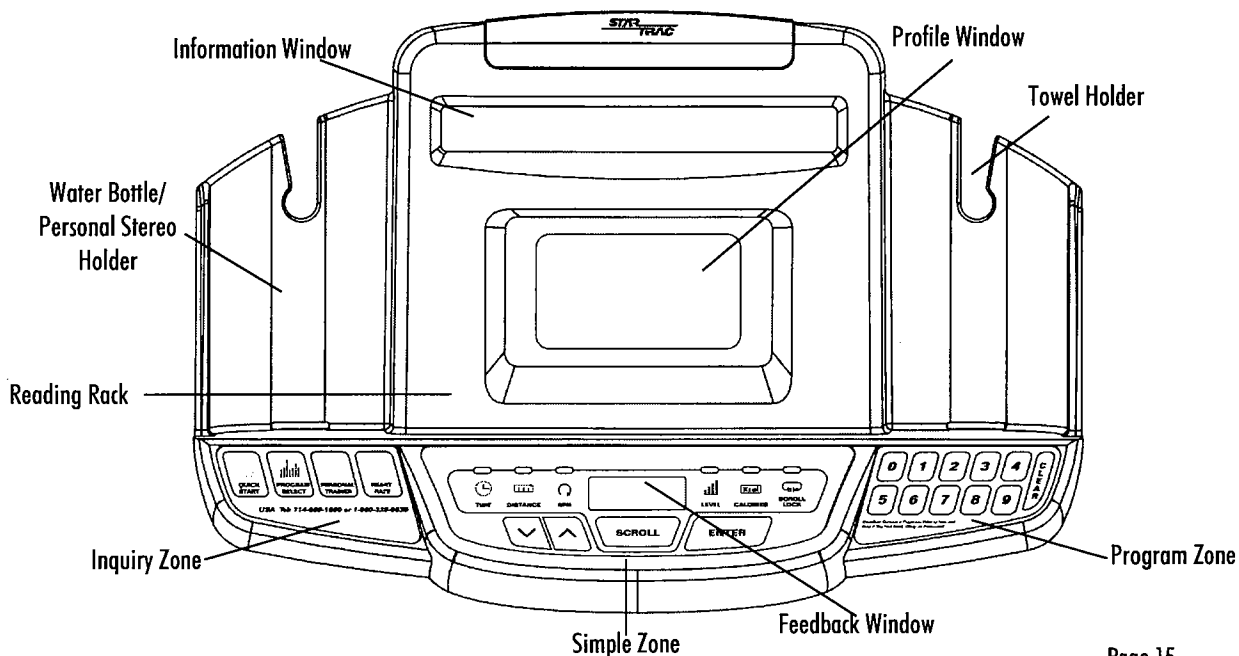

## OWNER'S MANUAL

**IMPORTANT:** The Pro Bike can run self-powered or with an auxiliary power pack. In either configuration, you simply begin pedaling to operate the equipment. The display only remains activated while you are pedaling in self-powered mode. To program your workout, it is important that you continue pedaling.

### Information Window

The Information Window (identified on the previous page) provides two types of information: prompts for user inputs, and statistics that will scroll by during your workout. These statistics include:

| STATISTIC       | DESCRIPTION  |
|-----------------|--|
| MPH/KPH         | Miles or kilometers per hour of your current speed. (Either MPH or KPH can be chosen in the Display Settings, which are described in Chapter 7.)   |
| CAL/HR          | Calories you are burning per hour.   |
| MIN/MILE        | Minutes per mile.  |
| RPM             | Revolutions per minute.  |
| METS            | Accumulated intensity of your workout measured in METs. (Must be turned on in the Display Settings, which are described in Chapter 7.)   |
| Watts           | Accumulated power you have expended. (Must be turned on in the Display Settings, which are described in Chapter 7.)  |
| HR              | Heart rate displayed in beats per minute. (Only shown if you are wearing a Polar heart rate chest strap or holding the contact heart rate grips with both hands.)                          |
| AVG HR          | Average heart rate for this workout displayed in beats per minute. (Only shown if you are wearing a Polar heart rate chest strap or holding the contact heart rate grips with both hands.) |
| xx:xx remaining | Time remaining, shown in minutes and seconds (mm/ss). (Only shown if you selected a time goal.)  |
| x miles to go   | Miles remaining. (Only shown if you selected a distance goal.)   |
| x km to go      | Kilometers remaining. (Only shown if you selected a distance goal.)  |
| x cals to go    | Calories remaining. (Only shown if you selected a calories goal.)  |

## Profile Window

The Profile Window displays the workout course you have selected. A flashing lamp in the window indicates your location on the workout course.

## Inquiry Zone

The Inquiry Zone (shown below) has four keys that enable you to select the program you will use for your workout. A description of each key immediately follows the illustration.

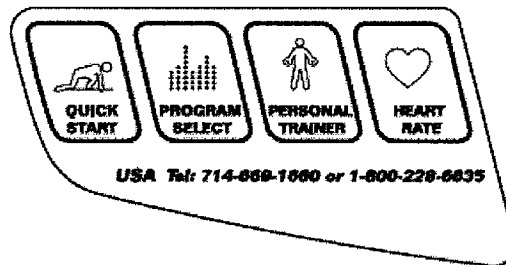

### Quick Start

With a single keystroke, you begin your workout without selecting a preset program. When using Quick Start, you can change the level of your workout at any time.



### Program Select

Scrolls through nine preset programs and enables you to quickly choose the workout you desire. For each program, you enter your target goal, level and weight; resulting in a completely customized workout.



### Personal Trainer

Places you in the Personal Training Studio where you can create and run customized training programs. Personal Training Studio is designed for use by personal trainers and requires a PIN code for access. For further instructions, see Chapter 5.



### Heart Rate

Allows you to choose between Dynamic Heart Rate Control (DHRC) and Steady Heart Rate Control (SHRC) if DHRC is set to "on" in the Display Settings. If DHRC is set to "off", this key allows you to display your current heart rate when you are wearing either a Polar heart rate chest strap, or holding both heart rate grips. For further instructions, see the end of this chapter.

### Simple Zone

The Simple Zone (shown below) includes the Feedback Window and four action keys.

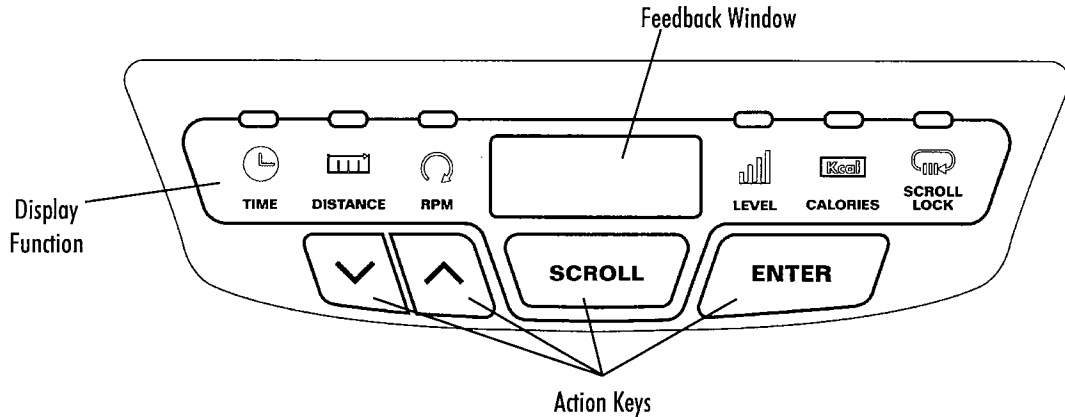

The action keys let you change, enter and view programming information. Instructions for using the action keys (which are described in the following section) are provided later in this section.



#### Up and Down Arrow

Use these keys to increase or decrease the level of your workout, or to change numeric entries when setting up a program.



#### Enter

Use this key to select programs and to enter information required for your workout or for specific features.



#### Scroll

Use this key to scroll through the information provided in the Feedback Window.

The Feedback Window displays information about your workout. You can use the SCROLL key to select the type of information (time, distance, speed, level, or calories) you wish to view. Or you can lock the scroll so that each of the information types is shown in sequence in the Feedback Window.

If you stop pedaling during a program workout, you will be placed in pause mode for 20 seconds. As soon as you stop pedaling, the Feedback Window displays a countdown from 20 seconds. To resume your workout, continue pedaling before the 20 seconds has elapsed. When you complete a program goal, you will go into cooldown mode for two minutes. When cooldown mode begins, the Feedback Window displays a countdown from two minutes.

## To Change the Information Provided in the Feedback Window

1. Press the SCROLL key until the lamp above the desired icon is lit. If you wish to view all the information, press the SCROLL key until the lamp above the SCROLL LOCK icon is lit. Following is a description of each icon.



**TIME**

### **Time**

Indicates the elapsed time in minutes and seconds (mm:ss) of your workout.



**DISTANCE**

### **Distance**

Indicates the elapsed distance, in either miles or kilometers, of your workout.



**RPM**

### **RPM**

Indicates the RPM (revolutions per minute) at which you are currently pedaling.



**LEVEL**

### **Level**

Indicates the current level of resistance (L=XX) for your workout.



**CALORIES**

### **Calories**

Indicates the accumulated number of calories you have burned during your workout.



**SCROLL  
LOCK**

### **Scroll Lock**

Places the Feedback Window into auto-scroll mode in which all of the information will be shown in sequence.



## OWNER'S MANUAL

### Program Zone

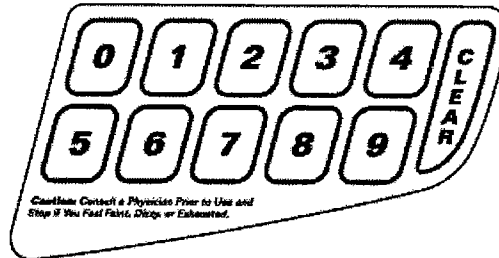
The Program Zone (shown below) is used to input data required for using programs and system set-up. This zone includes a ten-digit keypad (digits 0-9) and a CLEAR key that is used to clear an entry.



### GETTING STARTED

All you need to do to start your workout is to begin pedaling. The console will light up and you will be placed in Quick Start mode. During your workout, you can press a digit key or the   keys to change the level of your workout.

The Pro Bike provides several preset programs that have been designed for optimal interval training. You can choose from any of the following preset programs:



- **Manual**  
This program, which is similar to Quick Start, lets you enter a goal, level, and weight for a more customized workout.
- **Forest Ride**  
Similar to a brisk ride through a forest, this program offers a relatively easy workout that gradually increases your heart rate.
- **Trail Blazer**  
Offering a moderate workout, this program takes you up and down two hills with a brief rest in between.
- **Alpine Pass**  
By offering a series of steep hills and valleys, this program provides a rigorous workout for the serious user.
- **Mystery Ride**  
Mystery Ride randomly chooses from over 250 different hill and valley configurations, enabling you to add variety to your workout. Not only do you not know which course will be selected, the course won't be shown in the Profile Window—adding to the mystery of the workout.
- **Fat Burner**  
Using a quick series of peaks and valleys, this program offers a rewarding workout that is optimized for burning calories.

- **Custom Interval**  
You can design a custom workout with up to 20 intervals, each of a different length and duration.
- **¼ Mile Track or 400 Meter Track**  
By letting you take the course as quickly or slowly as you want, this workout accommodates both the serious and recreational user.
- **Fitness Test**  
Fitness Test is a six-minute workout, at 50 RPM, that identifies your fitness level and calculates your VO2 Sub Max, a physiological measurement of the body's ability to absorb oxygen, that has specific correlation to the fitness level.

### Using a Preset Program (Except Custom Interval and Fitness Test)

With the exception of the Custom Interval and Fitness Test programs, you will use the same procedure to use any of the preset programs. The Custom Interval and Fitness Test programs have unique set-up steps and features; therefore, additional steps are required.



For all of the programs except Fitness Test, you can select your goal from three options: time (duration in minutes), distance (miles or kilometers), or calories.

1. Start pedaling and do not stop until your workout is finished.
2. Press the PROGRAM SELECT key to scroll to the program you wish to use.
3. Press ENTER to select the program.
4. Press the appropriate digit to select a goal:  
1 = Time, 2 = Distance, 3 = Calories.
5. Use the keypad or   keys to enter the appropriate information when prompted. The required information varies according to the goal you entered, as shown in the following table:

|                        | TIME GOAL | DISTANCE GOAL    | CALORIES GOAL |
|------------------------|-----------|------------------|---------------|
| 1 <sup>st</sup> Prompt | Minutes   | Miles/Kilometers | Calories      |
| 2 <sup>nd</sup> Prompt | Weight    | Weight           | Weight        |
| 3 <sup>rd</sup> Prompt | Level     | Level            | Level         |

6. After each entry, press ENTER to save the information and continue. After you have entered the level, your workout will begin.

### Using the Custom Interval Program

1. Start pedaling and do not stop until your workout is finished.
2. Press the PROGRAM SELECT key to scroll to the Custom Interval program.
3. Press ENTER to select the program.
4. Press the appropriate digit to select a goal:  
1 = Time, 2 = Distance, 3 = Calories.
5. Use the keypad or   keys to enter the appropriate information when prompted. The required information varies according to the goal you entered, as shown in the following table:



|                        | TIME GOAL | DISTANCE GOAL    | CALORIES GOAL |
|------------------------|-----------|------------------|---------------|
| 1 <sup>st</sup> Prompt | Minutes   | Miles/Kilometers | Calories      |
| 2 <sup>nd</sup> Prompt | Weight    | Weight           | Weight        |

*As a default, the system divides your workout into 20 equal segments. For each segment, you must enter the level and duration (in minutes). For any segment, if you enter a value for time, distance or calorie (depending on your goal) that is greater or less than the default value, the number of segments will be increased or decreased accordingly. For instance, if you have a 20-minute goal, and enter eight minutes each for the first two segments and four minutes for the third segment, you will not be offered any additional segments.*

6. Enter the level for the first segment.
7. Press ENTER to set the level.
8. Enter the duration, in minutes, for the segment.
9. Press ENTER to set the duration.
10. Repeat steps 6 through 9 for each of the remaining segments.

### Using the Fitness Test Program

1. Start pedaling and do not stop until your workout is finished.
2. Press the PROGRAM SELECT key to scroll to the Fitness Test program.
3. Press ENTER to select the program.
4. Press the appropriate digit for your gender: 1 = Male, 2 = Female
5. Enter your weight and press ENTER.
6. Enter your age and press ENTER. The program will begin.

7. While wearing either a Polar heart rate chest strap, or holding both contact heart rate grips, pedal at 50 RPM for six minutes. The level will be set to 2. Use the   keys to increase the level to 3 or decrease the level to 1.

At the end of six minutes, the Pro Bike will beep and two values will be displayed in the Information Window: VO2 Sub Max and Fit Level. The fitness level ranges from 1 to 10, with 1 being very, very weak and 10 being very, very strong.

8. Continue pedaling in cool down mode.

### HEART RATE TRAINING PROGRAMS

Your Pro Bike features two programs designed to control your workout using a desired heart rate range or a specified heart rate:

- Dynamic Heart Rate Control (DHRC) is designed to gradually elevate your heart rate to the upper end of your training range, then gradually decrease your heart rate to the lower end, while varying your level of resistance.
- Steady Heart Rate Control (SHRC) is designed to maintain a selected training heart rate, while varying your level of resistance.

DHRC and SHRC can be operated by using either a Polar telemetry heart rate chest strap or the contact heart rate grips on your Pro Bike.

#### Dynamic Heart Rate Control

You can select your goal from three options: time (duration in minutes), distance (miles or kilometers), or calories.

Before using DHRC for the first time, we recommend that you calculate your UPPER HEART RATE (HR) LIMIT (75% of your maximum heart rate) and your LOWER HEART RATE (HR) LIMIT (60% of your maximum heart rate), using the following formulas. (Note: This feature requires at least an 18 BPM (Beats Per Minute) range between the upper and lower heart rates to ensure an interval workout.)

To calculate your training zone, use the following formulas. Note, you can determine your theoretical max HR by subtracting your age from 220 (220 - Age).

Upper Heart Rate Limit

(Your Theoretical Max HR) \_\_\_\_\_ x 0.75 = \_\_\_\_\_ UPPER HR LIMIT



Lower Heart Rate Limit

(Your Theoretical Max HR) \_\_\_\_\_ x 0.60 = \_\_\_\_\_ LOWER HR LIMIT





1. Start pedaling and do not stop until your workout is finished.
2. Press the HEART RATE key to choose either DHRC or SHRC.

## Star Trac Pro Bikes

### OWNER'S MANUAL

3. Press 1, then ENTER to select DHRC.
4. Press the appropriate digit to select a goal:  
1 = Time, 2 = Distance, 3 = Calories.
5. Use the keypad or   keys to enter the appropriate information when prompted. The required information varies according to the goal you entered, as shown in the following table:

|                        | TIME GOAL | DISTANCE GOAL    | CALORIES GOAL |
|------------------------|-----------|------------------|---------------|
| 1 <sup>st</sup> Prompt | Minutes   | Miles/Kilometers | Calories      |
| 2 <sup>nd</sup> Prompt | Weight    | Weight           | Weight        |
| 3 <sup>rd</sup> Prompt | Age       | Age              | Age           |

6. After each entry, press ENTER to enter the information and continue.
7. Using the keypad or   keys, enter your "UPPER HR LIMIT" (as calculated using the prior formula) and press ENTER.
8. Using the keypad or   keys, enter your "LOWER HR LIMIT" (as calculated using the prior formula) and press ENTER. Your workout program will begin.
9. Follow the instructions provided in the Information Window.



If you are using a Polar heart rate chest strap, your heart rate will be displayed continuously in the Profile Window. The level will increase and decrease accordingly to maintain your heart rate within the specified range. If your UPPER or LOWER range is not met with level changes, you will be instructed to "Increase Speed" or "Decrease Speed" accordingly. These messages will appear in the Information Window.

If you do not have a Polar heart rate chest strap, you must use the contact heart rate grips on your Pro Bike to monitor your heart rate. Lightly grip the handles when instructed and continue to do so throughout the program.



#### Steady Heart Rate Control

You can select your goal from three options: time (duration in minutes), distance (miles or kilometers), or calories.

1. Start pedaling and do not stop until your workout is finished.
2. Press the HEART RATE key to choose either DHRC or SHRC.
3. Press 2, then ENTER to select SHRC.
4. Press the appropriate digit to select a goal:  
1 = Time, 2 = Distance, 3 = Calories.

5. Use the keypad or   keys to enter the appropriate information when prompted. The required information varies according to the goal you entered, as shown in the following table:

|                        | TIME GOAL | DISTANCE GOAL    | CALORIES GOAL |
|------------------------|-----------|------------------|---------------|
| 1 <sup>st</sup> Prompt | Minutes   | Miles/Kilometers | Calories      |
| 2 <sup>nd</sup> Prompt | Weight    | Weight           | Weight        |
| 3 <sup>rd</sup> Prompt | Age       | Age              | Age           |

6. After each entry, press ENTER to save the information and continue.
7. Using the keypad or   keys, enter your desired heart rate and press ENTER. Your workout program will begin.
8. Follow the instructions provided in the Information Window.

If you are using a Polar heart rate chest strap, your heart rate will be displayed continuously in the Profile Window. The level will increase and decrease accordingly to maintain your specified heart rate. If your specified heart rate is not met with level changes, you will be instructed to “Increase Speed” or “Decrease Speed” accordingly. These messages will appear in the Information Window.

If you do not have a Polar heart rate chest strap, you must use the contact heart rate grips on your Pro Bike to monitor your heart rate. Lightly grip the handles when instructed and continue to do so throughout the program.

Note: The performance of the contact heart rate grips may not always be accurate due to biological differences among people. For this reason, when the contact heart rate grips are used, the unit may not be able to calculate the correct heart rate for some people. The contact heart rate also can be affected by body oils, metal in clothing, and outside electrical interference.

### **FITLINXX**

If your club or fitness facility is equipped with FitLinxx and you have been assigned an active ID number, just follow these steps:

1. Start pedaling and do not stop until your workout is finished.
2. Using the keypad, enter your five-digit FitLinxx ID number and press ENTER. (As not all facilities are FitLinxx equipped, check with facility management before trying to enter an ID number.)

**OWNER'S MANUAL**

3. If your ID is accepted, follow the prompts to begin your workout.

or

If your ID is not accepted, enter your five-digit FitLinxx ID number again. After two unsuccessful attempts, contact facility management for assistance. If your ID is accepted, follow the prompts to begin your workout.

Once you have completed your workout, the time, distance, and calories burned during your workout will be sent automatically to the on-site FitLinxx management system for review by a qualified instructor or trainer.

# 5

## PERSONAL TRAINING STUDIO™

Star Trac's unique Personal Training Studio lets up to 50 personal trainers design and save five custom cycling cross-training programs. This is especially beneficial to fitness professionals who want to create and store their own sport-specific exercise programs, such as mountain biking, or more results-oriented programs, like weight management. Personal Training Studio lets trainers:

- Customize their client workouts
- Make their clients accountable for performing the recommended amount and intensity of cardio exercise
- Provide feedback to users to enable them to accurately assess their cardio program.

Using the Personal Trainer Master PIN number (4321), you can assign up to 50 four-digit PIN numbers, each of which can customize up to five cross-training programs. You also can use the Personal Trainer Master PIN code to delete a PIN code and view the list of all assigned PIN codes.



### ASSIGNING PERSONAL TRAINER PIN CODES

You can use the Personal Trainer Master PIN code to assign up to 50 four-digit PIN codes. You can delete a PIN code at any time or scroll through the list of PIN codes. The default Master PIN code is 4321.

#### Adding and Deleting a Personal Trainer PIN Code

1. While pedaling, press the PERSONAL TRAINER key.
2. Enter the Personal Trainer Master PIN code (4321) and press ENTER.
3. Press 1 to add a PIN code.  
or  
Press 2 to delete a PIN code.
4. Enter the four-digit PIN code to be added or deleted.
5. Press ENTER. "PIN saved" or "PIN deleted" will be shown in the Information Window to confirm the addition or deletion.
6. Repeat steps 3, 4 and 5 for each PIN code you wish to add or delete.
7. Press ENTER to exit the Personal Training Studio.





### Viewing the Personal Trainer PIN Codes

1. While pedaling, press the PERSONAL TRAINER key.
2. Enter the Personal Trainer Master PIN code (4321) and press ENTER.
3. Press 3 to view all the PIN codes.
4. Press the   keys to scroll through the list of PIN codes.
5. Press ENTER to return to the Personal Training Studio administration menu.
6. Press ENTER to exit the Personal Training Studio.



### USING THE PERSONAL TRAINING STUDIO

Once you have assigned a Personal Trainer PIN code, a trainer can use it to create/edit, delete or run up to five customized cross-training programs.





#### Running a Personal Trainer Program

1. While pedaling, press the PERSONAL TRAINER key.
2. Enter an existing Personal Trainer PIN code and press ENTER.
3. Press 1 to run a program.
4. Press the   keys to scroll to the program you wish to run. The program number will be shown in the Information Window and the profile will be shown in the Profile Window.
5. Press ENTER to select the program.
6. Press the appropriate digit to select a goal:  
1 = Time, 2 = Distance, 3 = Calories.
7. Use the keypad or   keys to enter the appropriate information when prompted. The required information varies according to the goal you entered, as shown in the following table:



|                        | TIME GOAL | DISTANCE GOAL    | CALORIES GOAL |
|------------------------|-----------|------------------|---------------|
| 1 <sup>st</sup> Prompt | Minutes   | Miles/Kilometers | Calories      |
| 2 <sup>nd</sup> Prompt | Weight    | Weight           | Weight        |
| 3 <sup>rd</sup> Prompt | Level     | Level            | Level         |

8. After each entry, press ENTER to enter the information and continue.
9. Press the   keys or a digit on the keypad during your workout to select a new level. If you use the keypad, press ENTER after entering a value.

### Creating/Editing a Personal Trainer Program

1. While pedaling, press the PERSONAL TRAINER key.
2. Enter an existing Personal Trainer PIN code and press ENTER.
3. Press 2 to edit a program.
4. Press the   keys to scroll to the program you wish to create/edit. The program number will be shown in the Information Window and the profile will be shown in the Profile Window.
5. Press ENTER to select the program.
6. Press the   keys to select a level for the first segment.
7. Press SCROLL to advance to the next segment.
8. Continue with steps 6 and 7 until you have set a desired level for each of the 20 segments.
9. Press ENTER to save the program and exit to the Personal Training Studio main menu.
10. Press ENTER to exit the Personal Training Studio.

### Deleting a Personal Trainer Program

1. While pedaling, press the PERSONAL TRAINER key.
2. Enter an existing Personal Trainer PIN code and press ENTER.
3. Press 3 to delete a program.
4. Press the   keys to scroll to the program you wish to delete. The program number will be shown in the Information Window and the profile will be shown in the Profile Window.
5. Press ENTER to select and delete the program.
6. Press ENTER to return to the Personal Training Studio main menu.
7. Press ENTER to exit the Personal Training Studio.

# Star Trac Pro Bikes

## OWNER'S MANUAL

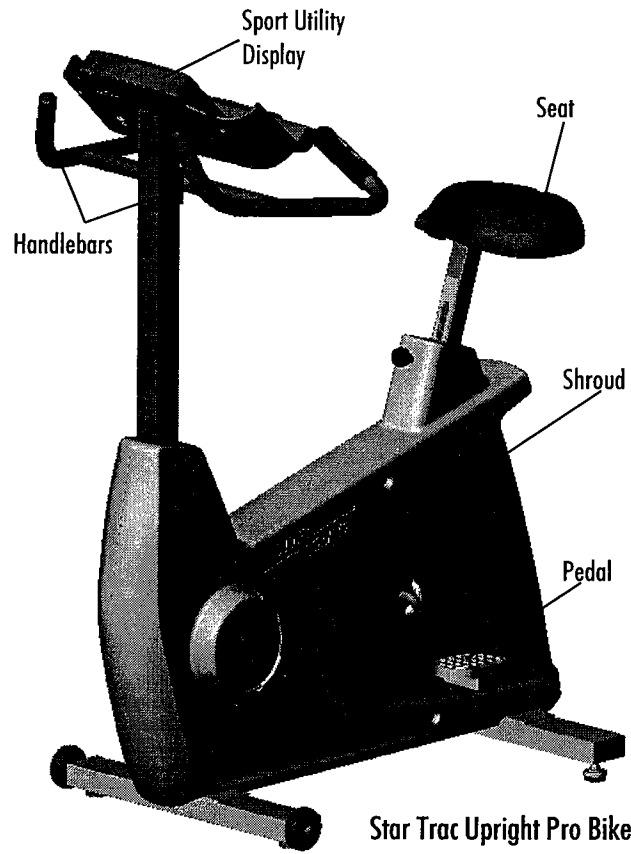

Star Trac Upright Pro Bike

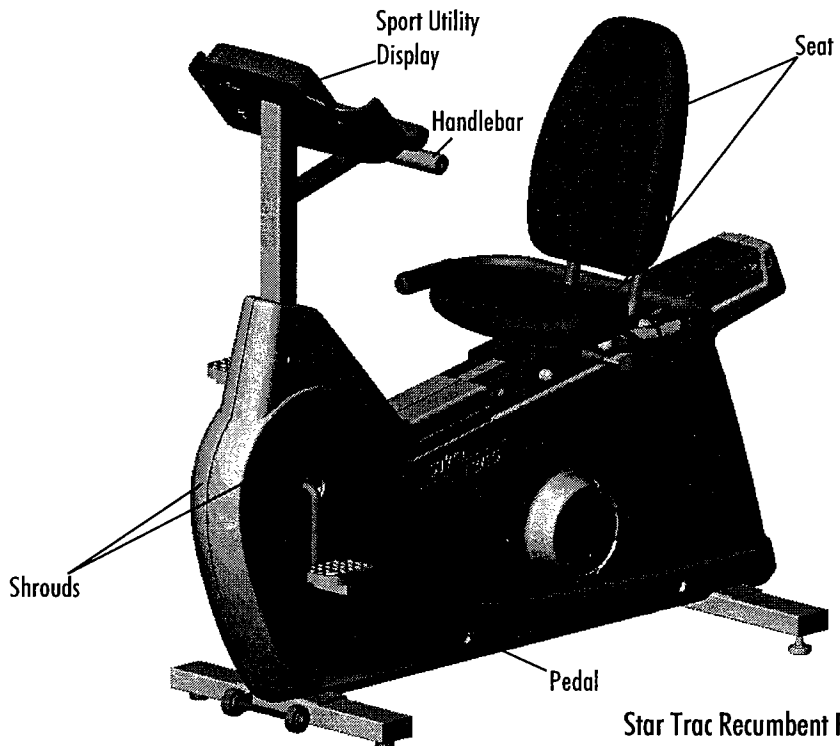

Star Trac Recumbent Pro Bike

---

# 6

## PREVENTATIVE MAINTENANCE

With durable, high performance components, Star Trac Pro Bikes are designed for heavy usage and minimal maintenance. To keep your Pro Bike in top condition, Star Trac strongly recommends that you perform daily, weekly, and monthly maintenance routines.

Any unusual symptoms, such as a loud, continuous noise, should be reported immediately to Star Trac Product Support at (800) 503-1221 or (714) 669-1660.

### DAILY MAINTENANCE

Remove dust, dirt and other substances from the Pro Bike using a clean, soft cloth and a liquid, non-abrasive cleaner. Wipe the exterior of the display board, handlebars, seat, pedals, and shrouds.

### WEEKLY MAINTENANCE

Each week, perform the following activities:

- Vacuum the floor under and around the Pro Bike.
- Inspect the screws of the Sport Utility Display panel to ensure the screws are not loose. Retighten if necessary.
- Inspect the Sport Utility Display panel for wear.

### MONTHLY MAINTENANCE

Each month or as needed, perform the following activities:

- Check that the seat, pedals, and shrouds are secure.
- Tighten the handlebars by turning the four attaching screws with the Combo Wrench.
- Tighten the pedals to their respective crank arms using the Combo Wrench.
- Tighten the shrouds by turning their respective fasteners with the Hex Key.

This page has been intentionally left blank.

# 7

## DISPLAY SETTINGS

The Display Settings mode allows you to view and customize several universal settings for your Pro Bike. The values set for the Display Settings parameters apply to all users.

### DISPLAY SETTING PARAMETERS

The following nine parameters can be customized to suit your specific needs. Upon delivery, the settings are set to the default values shown.

| PARAMETER | DESCRIPTION   | DEFAULT VALUE |
|-----------|---|---------------|
| Minutes   | Sets the maximum workout time, in minutes. The selection can be between 1 and 99. This also is the Quickstart workout time.   | 60            |
| Units     | Sets the units to English units or Metric units. If English is selected, distance will be shown in miles (displayed in tenths of a mile), speed in miles per hour, and weight in pounds. If Metric is selected, distance will be shown in kilometers (displayed in tenths of a kilometer), speed in kilometers per hour, and weight in kilograms. | Eng (English) |
| Weight    | Sets the weight (in pounds) that will be displayed as the default when users use a preset program. This number is provided as a default only; users will be prompted to enter their weight, which is used for calculating total calories burned. This value is interpreted in the current units selected.   | 155           |



| PARAMETER | DESCRIPTION  | DEFAULT VALUE |
|-----------|--|---------------|
| HR        | Activates and deactivates the Polar Heart Rate and Contact Heart Rate functions.           | Pol (Polar)   |
| DHRC      | Enables or disables the Dynamic Heart Rate Control and Steady Heart Rate Control programs. | On            |
| RPM       | Enables or disables the revolutions per minute (RPM) display.                              | On            |
| Watts     | Enables or disables the Watts display.   | Off           |
| Mets      | Enables or disables the Mets display.  | Off           |
| Language  | Selects the language used in the Information Window.                                       | English       |

### ENTERING DISPLAY SETTINGS MODE

You must enter the Display Settings Mode within 12 seconds after the display becomes active. If you are using the Pro Bike, or miss the 12-second window, you must stop pedaling and wait for the equipment to shut down before attempting to enter the Display Settings Mode.

1. With the display off and the equipment idle, begin pedaling. Within 12 seconds after the display is active, press the ENTER key, digit 0 key and digit 1 key simultaneously, then release the 1 key.
2. When you hear a series of beeps and see "Display Settings" in the Information Window, the Display Settings mode is active. Release the ENTER and 0 keys.

### VIEWING AND CHANGING DISPLAY SETTINGS

1. While in Display Settings mode, press the SCROLL key to scroll through the display setting parameters and to select the parameter you wish to view or change. For each parameter, the current setting will be displayed in the Information Window.
2. Press the   keys to scroll through the possible values for the parameter and to set the new value.
3. Press the SCROLL key to advance to the next parameter.
4. Press the ENTER key to save the new settings, exit Display Settings mode, and return to the standard operating mode.

# 8

## TROUBLESHOOTING

Star Trac Pro Bikes perform a self-test at the beginning of every workout. If a problem is detected, a message will be displayed before or after the workout (depending on the type of problem).

### START-UP SERVICE MESSAGES

The following messages are displayed at the beginning of a workout:

| MESSAGE       | DESCRIPTION   |
|---------------|---|
| Key Down      | One or more keys on the keypad are stuck in an "on" mode. This can occur if the user presses keys before the system is turned on. Call Star Trac Product Support for assistance if the <i>Key Down</i> message continues to be displayed. |
| Needs Service | A failure has occurred in an electronic component. Call Star Trac Product Support for assistance.   |

This page has been intentionally left blank.

## REGULATORY INFORMATION

This chapter provides regulatory information pertaining to Star Trac Pro Bikes.

### FCC AND OTHER DOMESTIC REGULATIONS

This device has been tested and found to comply with the limits for a Class B digital device, pursuant to Part 15 of FCC rules. Under the FCC guidelines, operation is subject to the following two guidelines: (1) This device may not cause harmful interference, and (2) this device must accept any interference received, including interference that may cause undesired operation.

The Star Trac Pro Bike generates and uses radio frequency energy. If the product is not installed and used in accordance with the instructions provided in the owner's manual, interference with radio communications may occur. Likewise, if unapproved accessories are installed, interference with radio communications may occur. The intent of the FCC Class B limit is to provide reasonable protection against harmful interference in a residential installation. However, there is no guarantee that interference may not occur in a specific installation. In the event that interference is experienced, turn off the unit to verify that it is the source. If the interference clears with the unit off, then try each of the following measures and combinations thereof:

- Reorient or relocate the Pro Bike.
- Reorient or relocate the receiving antennae for your television, radio, or VCR.
- Connect the unit to a different power outlet if you are using the AC adapter option.
- Consult Star Trac Product Support, your authorized dealer, or a qualified radio/television technician for help.

This product also has been tested to meet the following standards:

- UL 1647 (Massage and Exercise Machine Standard, Applicable Sections)

### CANADIAN DOC AND OTHER REGULATIONS

This Class B digital apparatus meets all requirements of the Canadian Interference Causing Equipment Regulations.

This product has been tested to meet: CSA 22.2 No. 68, Applicable Sections.

Cet appareil numérique de la classe B respecte toutes les exigences du Règlement sur le matériel brouilleur du Canada.

Cet appareil a été testé pour être conforme à la norme CSA 22.2 No 68 (articles applicables).

### EUROPEAN APPLICATIONS

This product conforms to the requirements of the European Council Directives:

- 89/336/EEC, Electromagnetic Compatibility
- 92/590/EEC, General Product Safety Directive
- 73/23/EEC, Electrical Equipment Low Voltage Safety Directive

Under the directives, the product was tested to the following standards:

#### **EN 55014-2 (1997)**

EN 6100-4-2  
EN 6100-4-4  
EN 6100-4-5 (1995)  
EN 6100-4-11 (1995)  
EN V 50204

ESD  
Electrical Fast Transients  
High Energy Surge  
Voltage Dips and Interruptions  
Conducted Immunity

#### **EN 6100-4-3 (1995)**

Radiated Immunity

#### **EN 55014-1 (1997)**

Disturbance Power, Conducted Emissions

#### **EN 50081-1 (1992)**

Conducted & Radiated Emissions

#### **EN 6100-3-2 (1995)**

Harmonic Current Emissions

#### **EN 6100-3-3 (1995)**

Flicker and Voltage Fluctuation

#### **EN 957-1**

Safety of Machinery



P/N: 620-4734 Revision A  
MARCH 2000

World Headquarters:  
14410 Myford Rd, Irvine, CA 92606 • Tel: 800-228-6635, 714-669-1660 • Fax: 714-508-3303 • <http://www.startrac.com>

