

Star Trac Instinct™
Pectoral Fly / Rear Deltoid

OWNER'S MANUAL



STAR TRAC
14410 Myford Road
Irvine, California 92606
Telephone: (800) 228-6635, (714) 669-1660
Fax: (714) 508-3303
<http://www.startrac.com>
email: support @startrac.com



TABLE OF CONTENTS

Introduction	4
About This Manual	4
Safety Instructions	5
Assembly and Setup	6
Parts and Materials	6
Siting Requirements	6
Unpacking	6
Assembly	7
Anchoring	11
Exercise Guidelines	11
General Guidelines	11
Product Use and Maintenance	11
Preventative Maintenance	12
Maintenance Schedule	12
Maintenance Procedures	13
Labels and Placards	15
Warranty and Disclaimer	16

Copyright 2006. Star Trac by Unisen, Inc. All rights reserved, including those to reproduce this book or parts thereof in any form without first obtaining written permission from Star Trac.

Every effort has been made to keep this information current; however, periodically, changes are made to the information herein, and these changes will be incorporated into new editions of this publication. All product names and logos are trademarks of their respective owners. Printed in the USA.



INTRODUCTION

Thank you for choosing the *STAR TRAC INSTINCT PECTORAL FLY / REAR DELTOID*. This unit has been designed to provide the user the most rewarding experience based upon the carefully planned features it possesses. The design elements of this product will provide you with a comfortable, intuitive, safe and reliable experience, guiding you to a habit-forming lifestyle. Our mission is to provide products to mold lifelong habits for health and fitness, and the *INSTINCT PECTORAL FLY / REAR DELTOID* will provide the path to meet your goals.

ABOUT THIS MANUAL

This manual is applicable to the *INSTINCT PECTORAL FLY / REAR DELTOID*. The manual is divided into eight sections, as follows:

Introduction

Provides an overview of each section within the manual.

Safety Instructions

Provides guidelines for safely operating the *INSTINCT PECTORAL FLY / REAR DELTOID*.

Assembly and Setup

Provides instructions for unpacking, assembling and setting up the *INSTINCT PECTORAL FLY / REAR DELTOID*.

Exercise Guidelines

Provides general guidelines to be followed when using the *INSTINCT PECTORAL FLY / REAR DELTOID*.

Preventative Maintenance

Describes the preventative maintenance measures required to keep the *INSTINCT PECTORAL FLY / REAR DELTOID* in top condition.

Labels and Placards

Provides illustrations and part number information for labels and placards used on *STAR TRAC INSTINCT* products.

Regulatory Information

Provides warrant and servicing information for the *INSTINCT PECTORAL FLY / REAR DELTOID*.

WARRANTY & DISCLAIMER

STAR TRAC warrants all frameworks for a period of 10 years. All moving parts are warranted for 1 year. 10 year limited warranty on structural frame not including coatings. 90 days on upholstery stitching only, cables and belts. Warranty is for parts only. Warranty is good and available to the original purchaser only as noted by **STAR TRAC** invoice and is not transferable nor assumable. **STAR TRAC** cannot warrant products that have been abused, neglected and or poorly maintained. All equipment should be reviewed at the time of delivery for damage, breakage, loosening of nuts and bolts, components and or any other moving parts. Any and all claims for warranty must be received in writing within 70 days of defect. Do not alter, modify or redesign any **STAR TRAC** products or use any replacement parts or materials other than those components original to **STAR TRAC** as it will limit the warranty and liability of **STAR TRAC**. **STAR TRAC** reserves the right to change, replace or modify products, parts, accessories and or design without notice. Deposits on cancelled orders will be subject to handling and restocking charges.

WHAT IS COVERED

This **STAR TRAC INSTINCT PECTORAL FLY / REAR DELTOID** is warranted to be free of all defects in material and workmanship.

WHO IS COVERED

The original purchaser or any person receiving the Product as a gift from the original purchaser.

WHO PAYS TRANSPORTATION & INSURANCE FOR SERVICE

If the Product or any covered part must be returned to a service facility for repairs, We, **STAR TRAC**, will pay all transportation and insurance charges for the first year. You are responsible for transportation and insurance charges for all subsequent years.

WHAT WE WILL DO TO CORRECT COVERED DEFECTS

We will ship to you any new or rebuilt replacement part or component, or, at our option, replace the Product. Such replacement parts are warranted for the remaining portion of the original warranty period.

WHAT IS NOT COVERED

Any failures or damage caused by unauthorized service, misuse, accident, negligence, improper assembly or installation, debris resulting from any construction activities in the Products environment, rust or corrosion as a result of the Product(s) location, alterations or modifications without our written authorization or by failure on your part to use, operate and maintain the Product as set out in your Owners Manual.

OWNERS MANUAL

It is VERY IMPORTANT THAT YOU READ THIS MANUAL before operating the Product. Remember to perform the periodic maintenance requirements specified in the Manual to assure proper operation and your continued satisfaction.

HOW TO GET PARTS & SERVICE

Simply call Customer Support Services at (800) 966-3539 or (951) 600-3800, Monday through Friday from 8:00 a.m. to 5:00 p.m. Pacific Standard Time, and tell them your name, address and the model number of your Product. They will tell you how to get a replacement part, or, if necessary, arrange for service where your Product is located or advise you on how and where to ship the Product for service. You can also contact us via Fax at (951) 600-1706 or e-mail us at

Before shipping:

1. Obtain a Return Authorization Number (RA#) from Customer Support Services
2. Securely pack your Product (use the original shipping carton, if possible)
3. Write the RA# on the outside of the carton
4. Insure the Product, and
5. Include a letter explaining the defect or problem and a copy of your proof of purchase if you believe the service is covered by warranty.

EXCLUSIVE WARRANTY

THIS LIMITED WARRANTY IS IN LIEU OF ALL OTHER WARRANTIES OF ANY KIND EITHER EXPRESSED OR IMPLIED, INCLUDING BUT NOT LIMITED TO THE IMPLIED WARRANTIES OF MERCHANTABILITY AND FITNESS FOR A PARTICULAR PURPOSE, AND ALL OTHER OBLIGATIONS OR LIABILITIES ON OUR PART. We neither assume nor authorize any person to assure for us any other obligation or liability concerning the sale of this Product. Under no circumstances shall we be liable under this warranty, or otherwise, of any damage to any person or property, including any lost profits or lost savings, for any special, indirect, secondary, incidental or consequential damages of any nature arising out of the use of or inability to use this Product. Some states do not allow the exclusion or limitation of implied warranties or of liability for incidental or consequential damages, so the above limitations or exclusions may not apply to you.

CHANGES IN WARRANTY NOT AUTHORIZED

No one is authorized to change, modify or extend the terms of this limited warranty.

EFFECT OF STATE LAWS

This warranty gives you specific legal rights and you may have other rights, which vary, from state to state.

OUR PLEDGE TO YOU

Our Products are designed and manufactured to the highest standards. **STAR TRAC** wants you completely satisfied with our Products and will do everything possible under the terms of this warranty to keep you secure in knowing you have bought the best!

SAFETY INSTRUCTIONS

Read this Owner's Manual carefully before assembling, servicing or using your **STAR TRAC INSTINCT PECTORAL FLY / REAR DELTOID**.

WARNING: SERIOUS INJURY MAY OCCUR IF THESE SAFETY PRECAUTIONS ARE NOT OBSERVED. UNDERSTANDING EACH AND EVERY WARNING TO THE FULLEST IS IMPORTANT. IF ANY OF THESE WARNINGS ARE UNCLEAR, CONTACT STAR TRAC PRODUCT SUPPORT FOR CLARIFICATION.

1. Do not use any equipment in any way other than designed or intended by the manufacturer. It is imperative that weight stack machines as well as any other **STAR TRAC INSTINCT** equipment is used properly to avoid injury.
2. Make sure there is enough room for safe access and operation of the **INSTINCT PECTORAL FLY / REAR DELTOID**.
3. Keep hands, feet, head, limbs, fingers and hair clear at all times from moving parts to avoid injury. Use appropriate positioning, speed and controlled movements.
4. DO NOT use any equipment that is damaged and or has worn or broken parts. Use only replacement parts supplied by **STAR TRAC**.
5. DO NOT wear loose or dangling clothing while using the **INSTINCT PECTORAL FLY / REAR DELTOID**. Keep away from all moving parts.
6. Obtain a medical examination prior to beginning an exercise program.
7. If at any time during exercise you feel faint, dizzy or experience pain, STOP IMMEDIATELY and consult your physician before continuing.
8. Children must NOT be allowed to operate the **INSTINCT PECTORAL FLY / REAR DELTOID**. Adolescents must be supervised when using the **INSTINCT PECTORAL FLY / REAR DELTOID**.
9. DO NOT attempt to fix a broken or jammed unit. Notify authorized personnel.
10. Use the **INSTINCT PECTORAL FLY / REAR DELTOID** only for the intended use. Obtain instruction on proper use of the unit. It is the purchaser's sole responsibility to properly instruct end users and supervising personnel as to the proper operating procedures of all **STAR TRAC INSTINCT** equipment. DO NOT modify the unit.
11. Load plates evenly and carefully to avoid tipping equipment and possible crushing injuries.
12. DO NOT use the **INSTINCT PECTORAL FLY / REAR DELTOID** if guards or shrouds are missing or damaged.
13. USE A SPOTTER.
14. DO NOT add incremental weights, except those provided by **STAR TRAC**.
15. MAINTAIN PLACARDS AND LABELS: Do not remove labels for any reason; they contain important information. If illegible or missing, contact the STAR TRAC Parts Department for replacement.
16. SECURING EQUIPMENT: The **INSTINCT PECTORAL FLY / REAR DELTOID** MUST be secured to the floor to stabilize and eliminate rocking or tipping over. This must be performed by a licensed contractor.
17. Make sure that each machine is set up and operated on a solid level surface. DO NOT install equipment on an uneven surface.
18. MAINTAIN ALL EQUIPMENT: Preventative maintenance is the key to ensuring smooth and reliable operation of the **INSTINCT PECTORAL FLY / REAR DELTOID**, as well as keeping your liability to a minimum. Inspect the unit prior to use. Give particular attention to the areas most susceptible to wear. DO NOT use if the unit is damaged or inoperable.
19. Ensure that adjustment, maintenance and/or repair of the **INSTINCT PECTORAL FLY / REAR DELTOID** is performed by qualified personnel ONLY. Immediately replace worn or damaged components then remove the **INSTINCT PECTORAL FLY / REAR DELTOID** from service until repairs are made.
20. Keep a repair log of all maintenance activities.
21. Routinely inspect all accessory clips that join attachments to weight belts or cables, and replace at the first sign of wear.
22. Use only weight selector pins supplied by **STAR TRAC** on weight stacks. Substitutes are forbidden.
23. Cables and belts pose an extreme liability if used when frayed. Always replace any cable or belt at first sign of wear (consult **STAR TRAC** Product Support if uncertain).
24. Fully insert the weight selector pin when selecting the desired weight. Partially inserted pins can cause weights to fall unexpectedly. NEVER remove the weight selector pin if any weights are suspended. NEVER attempt to release jammed weights or parts.
25. DO NOT use Lat Pulldown Bars on Multi-jungle Crossover cable systems or any other pulley systems. These bars are designed for lat pulldown machines ONLY. If improperly used, the Lat Bar could fall unexpectedly, striking the user when weight selector pin is removed.
26. Lat Pulldown Machines pose a danger if used with worn or damaged cables and connecting links. The user can be struck in the head if the cable or related parts break during use.
27. When adjusting any seat, knee hold down pad, range of motion limiter, foothold pad or any other type of adjuster, make certain that the adjusting pin is fully engaged in the retainer hole to avoid injury.

NOTE: It is the sole responsibility of the user / owner or facility operator to ensure that regular maintenance is performed.

ASSEMBLY AND SETUP

PARTS AND MATERIALS

The following parts are included with the **STAR TRAC INSTINCT PECTORAL FLY / REAR DELTOID**:

1	Frame, Weight Stack	1	26	Cap, Rubber	2
2	Frame, Main	1	27	Guide Post, Weight Stack	2
3	Support, Range-of-Motion Flywheel	1	28	Pulley (factory installed)	5
4	Bracket, Leverage Arm (factory installed)	2	29	Plate, Top, Weight Stack	1
5	Range-of-Motion Flywheel, Right (factory installed)	1	35	Shaft, Leverage Arm	2
6	Range-of-Motion Flywheel, Left (factory installed)	1	42	Washer, Large	6
8	Post, Seat	1	45	Weight, 5lb	4
9	Leverage Arm, Right	1	46	Weight, 10lb	6
10	Leverage Arm, Left	10	47	Weight, 15lb	4
13	Cushion, Seat	1	48	Screw, Retaining	2
14	Cushion, Back	1	49	Screw, Button Head Socket Cap, 10X130M	4
18	Shroud, Lower, Rear	1	50	Screw, Button Head Socket Cap, 10X95M	2
19	Shroud, Lower, Front	1	51	Screw, Button Head Socket Cap, 10X70M	2
20	Shroud, Upper	2	53	Screw, Button Head Socket Cap, 10X35M	4
21	Belt	1	54	Screw, Button Head Socket Cap, 10X30M	2
22	Support, Weight Stack	2	55	Screw, Button Head Socket Cap, 8X20M	6
23	Retainer, Belt	2	61	Washer, 10M	12
25	Selector Pin	1	62	Washer, 8M	6
			64	Lock Nut, Nylon Insert, 10M	8
			66	Nut, Tapped Hole	6

TOOLS REQUIRED

Most **STAR TRAC INSTINCT** machines can be assembled using the following tools:

- Metric Hex Key Wrenches - 2.5mm, 5mm, 6mm, 8mm, 10mm
- Channel Lock Pliers
- Metric Open-End Wrenches - 10mm, 15mm, 17mm
- Vice Grip Pliers
- Metric Ratchet Socket Wrench Set (including 17mm socket)
- Rubber Mallet
- Torque Wrench
- Phillips Head Screwdriver - #2

Your **INSTINCT PECTORAL FLY / REAR DELTOID** includes a hex key set and combination open-end wrench.

SITING REQUIREMENTS

Your **INSTINCT PECTORAL FLY / REAR DELTOID** requires approximately 32 square feet of floor space to ensure safe operation of the unit.

UNPACKING

Your **INSTINCT PECTORAL FLY / REAR DELTOID** is shipped in one or more shipping cartons. Each carton will generally contain one subassembly of the entire unit. To unpack:

- Remove the shipping straps from the outside of each shipping carton.
- Open the top of each carton and fold back all four flaps.
- Remove the packing materials, foam inserts, and ALL parts from each shipping carton. Keep the contents of each carton in a *separate area* to facilitate assembly. To ensure personal safety during assembly, place all packing materials *outside* the assembly area.
- Verify that all parts listed above are included in your shipment.

Take time now to enter your **INSTINCT PECTORAL FLY / REAR DELTOID** serial number in the space below. If parts are missing, or if you have any operational questions, please call Star Trac's Service department at (800) 503-1221; have your serial number ready.

Serial No. _____

LABELS AND PLACARDS

PECTORAL FLY/REAR DELTOID

PECTORAL FLY

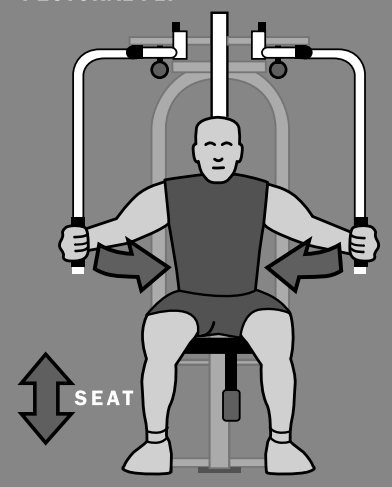

SEAT

- 1 ADJUST OVERHEAD POSITION TO FLY, GRASP HANDLES
- 2 BRING HANDLES TOGETHER IN FRONT OF BODY, RETURN SLOWLY

REAR DELTOID

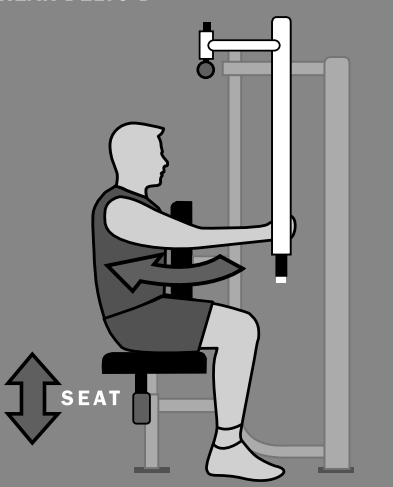

SEAT

- 1 ADJUST OVERHEAD POSITION TO REAR, GRASP HANDLES
- 2 PULL HANDLES APART AND BACK, RETURN SLOWLY

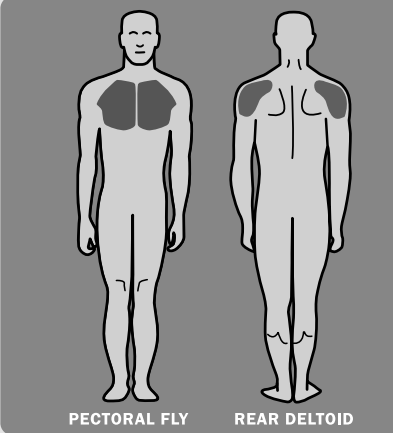

PECTORAL FLY REAR DELTOID

STAR TRAC

INSTINCT

WARNING
 As with all exercise equipment, consult your physician prior to use and stop if you feel faint, dizzy or exhausted. Inspect the machine before using it if it appears damaged or inoperable. For proper use and operation of this machine, please consult with management of the facility.

WWW.STARTRAC.COM U.S. 800-503-1221 INTERNATIONAL +1 714-669-1660



CAUTION

Pinch Points.
Keep hands away from moving parts.

WARNING

THIS MACHINE SHOULD BE PERMANENTLY SECURED TO THE FLOOR

WEIGHT BELT INSPECTION REQUIREMENTS

WARNING: REPLACE WORN WEIGHT BELTS IMMEDIATELY. FAILURE TO COMPLY CAN RESULT IN HAZARDOUS CONDITIONS FOR USERS OR OTHER BYSTANDERS.

Inspect all weight belts for evidence of excessive wear or other damage. Give particular attention to the following conditions:

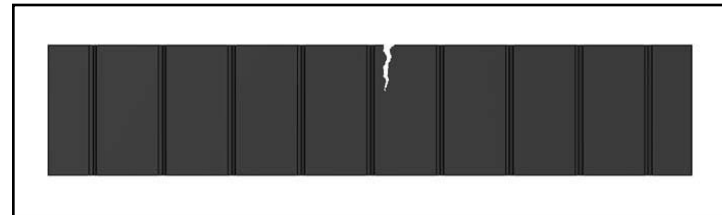

- Torn or cracked belt

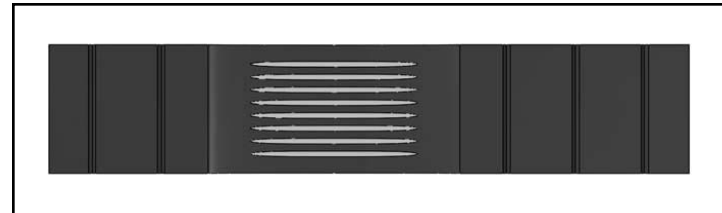

- Exposed belt cords

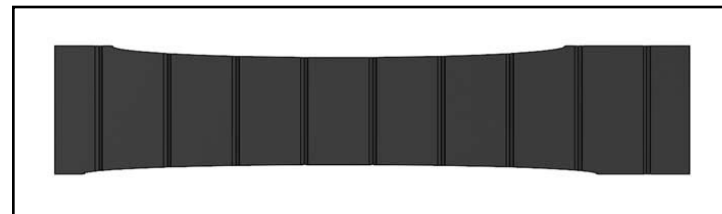

- Worn edges

ASSEMBLY

1. Assemble the Main Frame to the Weight Frame

Align the two drilled holes in the main frame (2) with the mating holes in the bottom of the weight stack frame (1). Secure the main frame to the weight frame using two screws (49), four washers (61), and two lock nuts (64). Tighten the nuts securely.

Align the two drilled holes in the bottom of the range-of-motion flywheel support (3) with the mating holes at the top of the main frame (2). Secure the support to the main frame using two screws (51), two washers (61), two washers (42) and two lock nuts (64). Tighten the nuts securely.

Align the two drilled holes in the crossbeam of the range-of-motion flywheel support (3) with the mating holes at the top of the weight stack frame (1). Secure the support to the weight stack frame using two screws (49), four washers (61) and two lock nuts (64). Tighten the nuts securely.

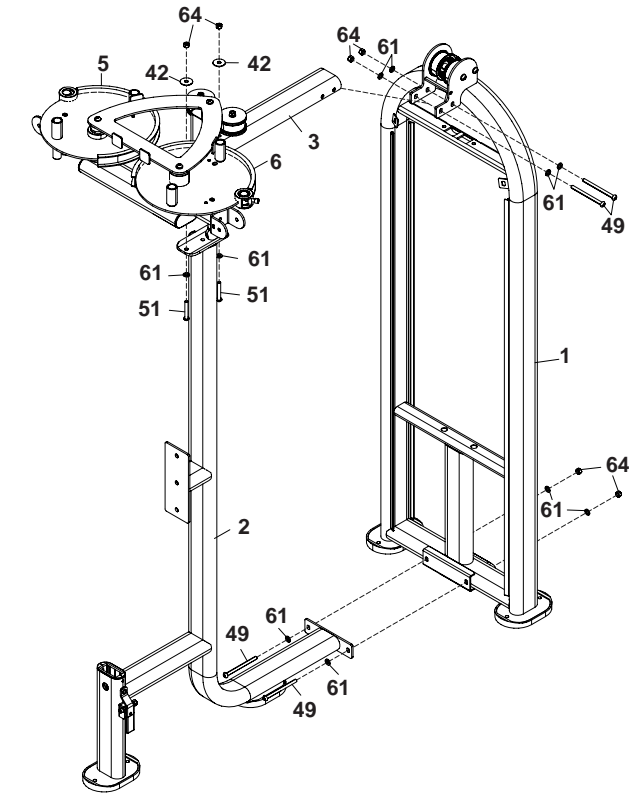

2. Install the Leverage Arms

NOTE: Two people are required to install the leverage arms; one to hold the leverage arm in position, and one to install the leverage arm shaft.

Insert one leverage arm shaft (35) in the right leverage arm (9).

Hold the right leverage arm (9) and shaft (35) in position between the flanges of the leverage arm bracket (4) (factory installed).

Secure the leverage arm (8) to the leverage arm bracket (4) using one screw (50), two large washers (42) and one lock nut (64). Tighten the nut securely.

Repeat for the left leverage arm (10).

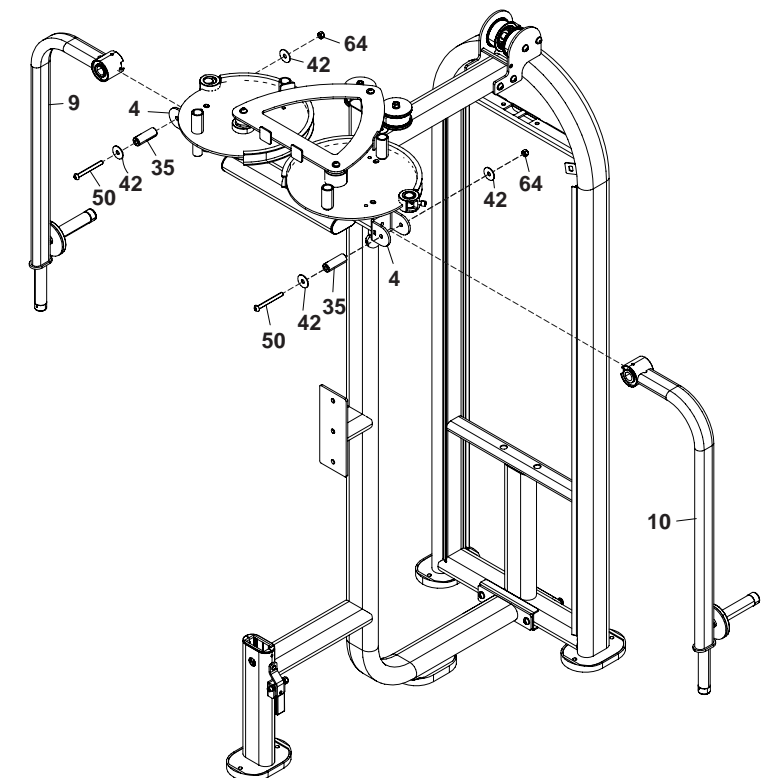

3. Assemble the Weight Stack

NOTE: Two people are required to assemble the weight stack; one to hold the weight stack guide posts in position, and one to assemble the weight stack components onto the posts.

Slide one weight stack support (22) onto each weight stack guide post (27).

Insert the weight stack guide posts (27) into the retaining holes in the base of the weight stack frame (1). BE SURE the drilled ends of the weight stack guide posts face upwards, toward the top of the weight stack frame.

WARNING: TO PREVENT INJURY, INSTALL THE WEIGHTS ONE AT A TIME.

Install weights (45, 46, 47) on the weight stack guide posts (27), one at a time, in the following sequence:

- Weight, 15lb (47) - four required
- Weight, 10lb (46) - six required
- Weight, 5lb (45) - four required

Slide the looped end of the lanyard on the selector pin (25) onto the shaft of the top plate (29).

NOTE: BE SURE to hold the lanyard in place when installing the top plate.

Install the top plate (29) on the weight stack guide posts (27), inserting the top plate shaft through the holes in the weights. Insert the selector pin (25) through one weight until it engages the top plate shaft.

Install one rubber cap (26) onto each weight stack guide post (27).

Lift up on one weight stack guide post (27) until the rubber cap (26) contacts the underside of the weight stack frame cross-member. Secure the post to the weight stack with one screw (54) and one washer (61). Repeat for the remaining guide post.

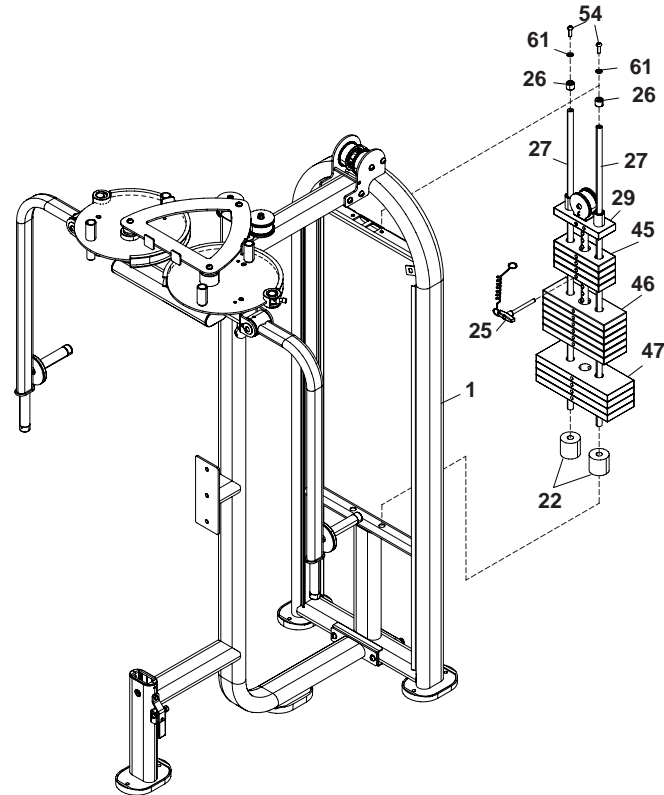

4. Install the Weight Belt

NOTE: The weight belt (21) is attached to the left and right range-of-motion flywheels (5, 6) using cinch fasteners (see detail below). Two people may be required to properly install and tension the weight belt.

Remove the retaining screws (48) and belt retainers (23) from the belt clamps on the left and right range-of-motion flywheels (5, 6).

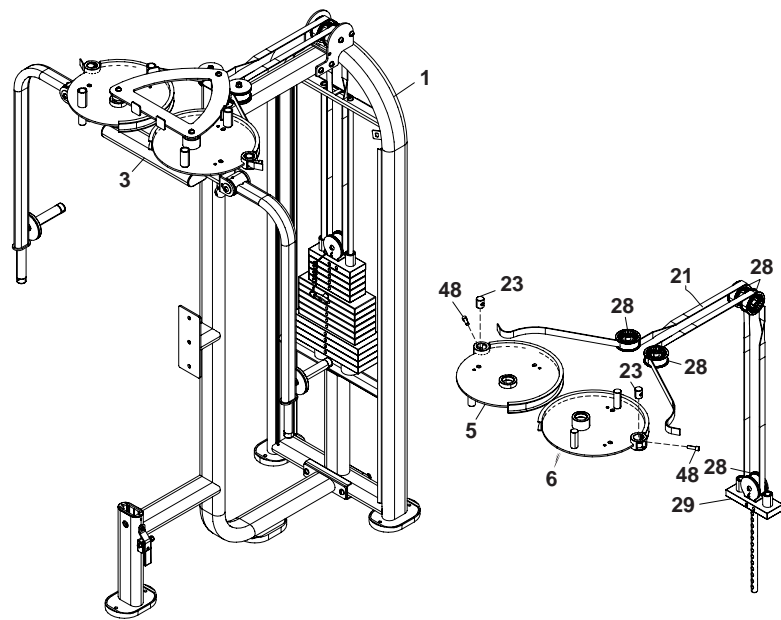
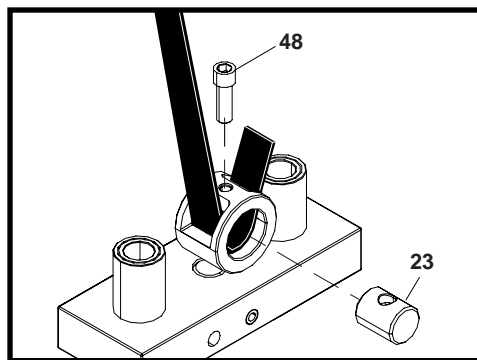

Insert one end of the weight belt (21) through the slot in the right range-of-motion flywheel (5) belt clamp until approximately one inch of the free end of the belt protrudes from the slot in the opposite side of the clamp.

MAINTENANCE PROCEDURES

FRAMEWORK MAINTENANCE

CAUTION: DO NOT use lacquer thinner, acetone, or other solvents to clean powder-coated finishes on the framework or other structural components. Solvents will dull the finish, and contain components that may remove the epoxy-based powder from the frame.

Framework and other structural components should be wiped down on a daily basis using a moistened with water. This will increase the longevity of protective powder-coat finishes. The framework should be inspected while cleaning for evidence of fatigue cracks, scratches or chips in the finish, loose hardware, worn or damaged weight belt, and other areas that may require attention.

Apply easy-application car wax to all powder-coated surfaces quarterly. Regular waxing will aid in preventing premature rusting due to corrosives found in perspiration, and will allow loose particles to be removed more easily when performing the daily wipe-down.

Procedures to repair scratches and chips depend on the severity of the damage:

- Surface scratches can generally be repaired by polishing with an automotive rubbing compound.
- Deep scratches and chips must be repaired by filling the damaged area using a “touch-up” bottle of color-matched paint (available through the **STAR TRAC** Parts Department). Fill the damaged area sparingly, using two or more coats. Allow the area to dry thoroughly between coats. Once the touch-up is complete, it can be left “as is”, or it can be blended and color-sanded to the surrounding surface.

NOTE: The process of blending and sanding repaired areas to the surrounding surface is difficult. It should be attempted **ONLY** by persons knowledgeable in this area.

The weight stack shrouds are made of PETG (glycol-modified polyethylene terephthalate). Proper cleaning is necessary to preserve the appearance of the shrouds. The following cleaners are compatible with PETG: Original Dawn®, Freon® T.F., Palmolive Liquid®, Top Job® and Windex® with Ammonia D.

CAUTION: Use ONLY recommended cleaning agents and procedures when cleaning the weight stack shrouds:

- **DO NOT use abrasive or highly alkaline cleaners to clean the shrouds.**
- **DO NOT use scrape the shrouds with squeegees, razor blades or other sharp instruments. DO NOT scrub or use brushes on the shrouds.**
- **DO NOT use Benzene, gasoline, acetone or tetrachloride to clean the shrouds.**
- **DO NOT clean the shrouds in hot sun or at elevated temperatures.**

Wash the shrouds using a clean sponge or soft cloth, and a solution of mild soap or detergent and lukewarm water. Rinse well with clean water, and dry thoroughly with a chamois or moist cellulose sponge to prevent water spots.

Remove stubborn accumulations (paint, grease, scuff marks) before drying by rubbing lightly with Isopropyl alcohol. Remove labels, placards or other adhesive residue using kerosene. If solvent does not penetrate the adhesive, heat the area using a hand-held blow dryer to soften the adhesive and aid in removal.

Clean all areas treated with solvent using a clean sponge or soft cloth, and a solution of mild soap or detergent and lukewarm water. Rinse thoroughly with clean water.

UPHOLSTERY MAINTENANCE

CAUTION: DO NOT use cleaners such as Lysol®, Armor All®, Windex®, or other abrasive detergents to clean upholstered surfaces. These products will remove moisture from the Naugahyde® upholstery, resulting in premature cracking.

Upholstered cushions should be cleaned on a daily basis to prevent damaged due to corrosives found in perspiration.

Wipe the top and sides of upholstered cushions using a cloth moistened with a solution of one part lanolin hand cleaner to nine parts water. After cleaning, wipe down using a dry towel to remove any residue.

CAUTION: Do not "high pin" and/or "double pin" a weight stack. This action is considered to be dangerous to users, and bystanders, and may damage your *INSTINCT PECTORAL FLY / REAR DELTOID*. Aside from the mechanical damage that may result, such action(s), in part, may cause the weight stack to crush or pinch fingers, hands and/or extremities. **DO NOT** use the unit if the top plate is elevated and/or pinned in a raised position. Seek assistance from authorized personnel to correct such a condition.

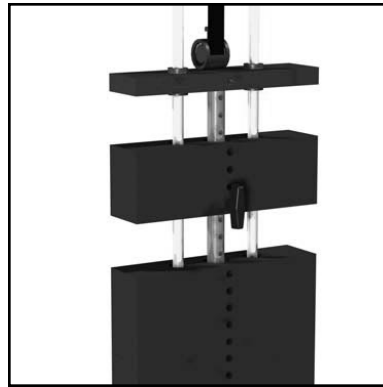

PREVENTIVE MAINTENANCE

MAINTENANCE SCHEDULE

Star Trac strongly recommends performing regular preventive maintenance on your *STAR TRAC INSTINCT PECTORAL FLY / REAR DELTOID*. Without regularly scheduled maintenance, normal wear and tear may cause cumulative effects, such as misalignment or premature wear, resulting in downtime. For this reason, we highly recommend following the maintenance schedules. Additionally, unusual symptoms, such as excessive noise during use, stiffness or free play in moving parts, etc., should be investigated and necessary corrective actions (adjustment or parts replacement) should be performed. If any components are found to be worn or damaged, the unit should be removed from service until repairs can be made. Only components supplied or approved by Star Trac shall be used to maintain and/or repair the unit.

DAILY MAINTENANCE

- Wipe down and inspect the framework and other structural components (see **FRAMEWORK MAINTENANCE** on page 13 for requirements). Check all attaching hardware for security. Tighten as needed.
- Clean and inspect the upholstered cushions and the hand grips (see **UPHOLSTERY MAINTENANCE** on page 13 for requirements).
- Clean and lubricate guide rods using a cotton cloth and break-free lubricant. Apply the lubricant to the cloth, then wipe up and down the guide rods as needed.
- Inspect weight belt for excessive wear or other damage. Check weight belt for proper tension (weight belt deflection at any point should not exceed 25 mm); adjust as needed. (See **WEIGHT BELT INSPECTION REQUIREMENTS** on page 14 for requirements.)
- Check range-of-motion flywheel bearings for evidence of sticking or binding; lubricate as needed bearings are equipped with fitting to facilitate lubrication).

WEEKLY MAINTENANCE

- Check the retainer screws at the left and right range-of-motion flywheels for security (retainer screws should be torqued to 400 inch-pounds). Tighten as needed.
- Check all labels and placards affixed to the unit for legibility and security. Replace illegible labels and placards as needed (see **LABELS AND PLACARDS** on page 15 for illustrations and part numbers of standard labels and placards used on *STAR TRAC INSTINCT* products).

MONTHLY MAINTENANCE

- Clean tops of bearings at weight stack top plate. Check for heavy buildup on guide rods below top plate (lift half of weight stack to perform a visual inspection and clean as necessary).

QUARTERLY MAINTENANCE

- Apply wax to powder-coated areas of the framework and other structural components.

While holding the free end of the belt, press down on the opposite side of the belt so it lays flat against the inside of the clamp.

Insert the belt retainer (23) into the belt clamp. BE SURE the tapped hole in the belt retainer is aligned with the mating hole in the belt clamp.

CAUTION: BE SURE to keep the weight belt straight when installing the retaining screw (48) in the belt retainer (23). Misalignment of the weight belt may bias the top plate, which can cause excessive contact of the top plate shaft with the weights, resulting in excessive noise during use, and potential hazards to the user or other bystanders.

Thread the retaining screw (48) through the belt clamp and into the belt retainer (23). Tighten the retaining screw to 400 inch-pounds.

Route the weight belt (21) over five pulleys (28) (factory installed), as illustrated.

Insert the free end of the weight belt (21) through the slot in the left range-of-motion flywheel (6) belt clamp, and pull through the opposite slot just until force is applied against the top plate (11). This will eliminate any slack in the belt and ensure proper tensioning.

While maintaining tension on the weight belt, press down on the free end of the belt so it lays flat against the inside of the belt clamp.

Insert the belt retainer (23) into the belt clamp. BE SURE the tapped hole in the belt retainer is aligned with the mating hole in the belt clamp.

Thread the retaining screw (48) through the belt clamp and into the belt retainer (23). Tighten the retaining screw to 400 inch-pounds.

Check for proper tensioning of the weight belt by applying lateral pressure to the belt at a point midway between two pulleys. Deflection of the weight belt should be less than 25 mm. Loosen the retaining screw (48) and adjust belt tension as needed.

5. Install the Seat and Back Cushions

Hold the back cushion (14) in place on the main frame (1). Secure the back cushion to the main frame with two screws (53) and washers (61). Tighten the screws securely.

Hold the seat cushion (13) in place on the seat post (8). Secure the seat cushion to the seat post with two screws (53) and washers (61). Tighten the screws securely.

Slowly slide the seat post (8) into the seat post guide in the main frame (2). While holding the seat post, press the ratchet handle to retract the locking pin, and slide the seat post fully into the seat post guide.

Release the ratchet handle. Slowly lift the seat post until the locking pin on the ratchet handle locks into a drilled hole in the seat post.

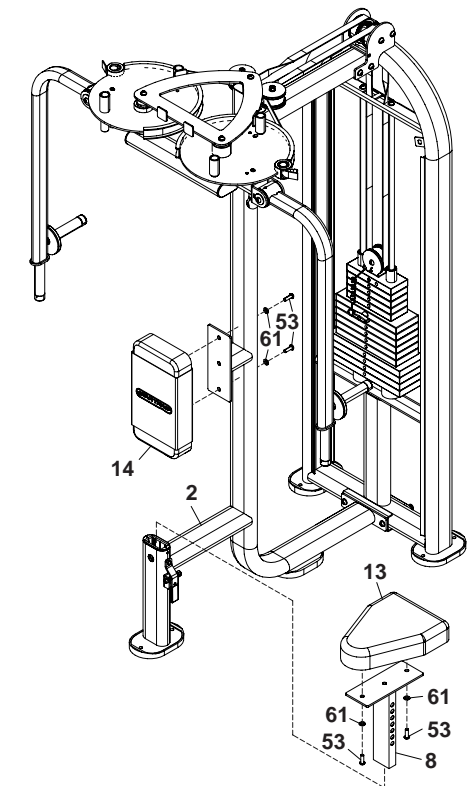

6. Install the Weight Stack Shrouds

NOTE: It is necessary to flex the lower shrouds (18, 19) slightly to engage the mating grooves in the weight stack frame (1).

Slide the lower front shroud (19) into the mating grooves in the weight stack frame (1). Slide the lower rear shroud (18) into the mating grooves in the weight stack frame.

Install one tapped hole nut (66) onto each of the six upper shroud mounting tabs on the weight stack frame (1).

Hold one upper shroud (20) in position against the weight stack frame (1), and secure the shroud to the frame using three screws (55) and washers (62).

Repeat for the remaining upper shroud (20).

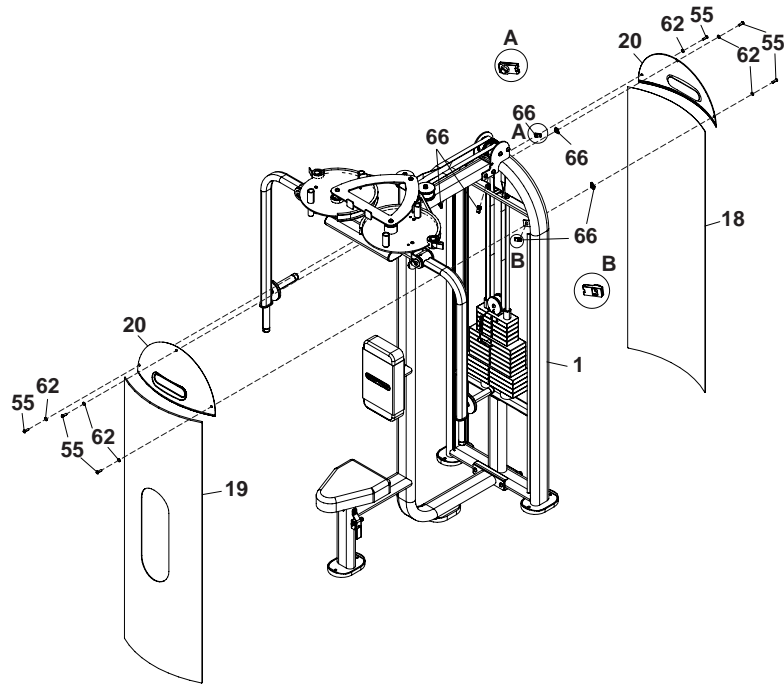

7. Final Assembly and Testing

Check all attaching parts to ensure they are tightened securely.

Verify operation of the seat post:

- Mount the unit. While holding the seat post, press the ratchet handle to retract the locking pin, and raise the seat. Release the ratchet handle, and verify the locking pin engages the first drilled hole at the first seat position.
- Repeat to verify the locking pin engages the drilled hole at all seat positions.
- Return the seat post to the "stowed" position.
- Verify the seat post slides smoothly, without evidence of sticking or binding.

Mount the unit. Engage the selector pin at a comfortable weight. Adjust the seat post as desired.

Operate the leverage arms and check the following:

- Verify operation of the leverage arms is smooth, without evidence of sticking or binding.
- Verify there is no evidence of "free play" when actuating the leverage arms from the "stowed" position.
- Verify there is no evidence of excessive noise during operation.

Return the leverage arms to the "stowed" position.

You have now completed assembly of your **INSTINCT PECTORAL FLY / REAR DELTOID**.

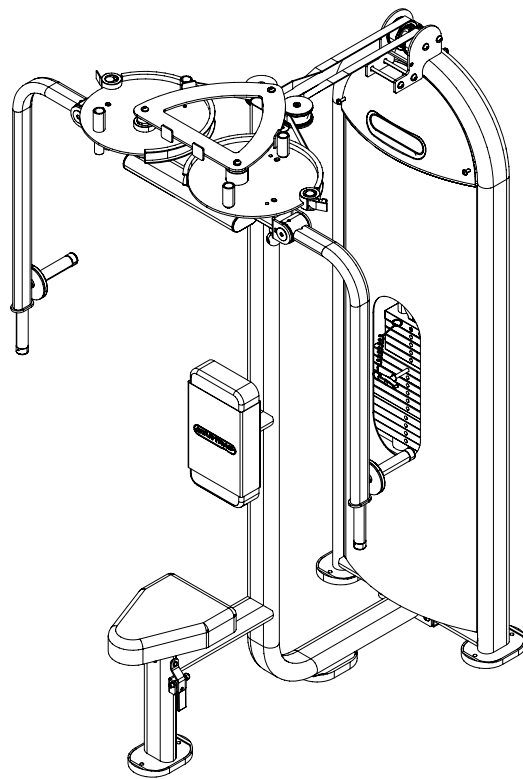

ANCHORING

IMPORTANT: The **INSTINCT PECTORAL FLY / REAR DELTOID** must be secured to the floor to stabilize and eliminate rocking or tipping over. This must be performed by a licensed contractor. Failure to anchor the unit will void the warranty. STAR TRAC shall not be liable for damage or injury caused by unanchored or improperly anchored units.

The **INSTINCT PECTORAL FLY / REAR DELTOID** must be anchored to the floor using through bolts or anchoring studs. Each foot pad on the unit provides two anchoring holes that will accommodate bolts of up to 12mm (7/16") diameter. Only one hole in each foot pad is required during anchoring. The holes used for anchoring may be selected based on installation site requirements or customer preference.

Anchoring bolts/studs must meet the following requirements:

- Anchor bolts shall be Grade 8.8 or Grade SAE 5.
- Anchoring bolts or studs shall have a minimum size of 6mm (1/4") diameter; 8mm (5/16") diameter bolts/studs are recommended.
- Pull-out force shall be 100kg (2201 lbs) minimum for any single anchor. This will ensure a secure anchoring system and safe operation of the unit by all users.

EXERCISE GUIDELINES

GENERAL GUIDELINES

As with any exercise program, strength training involves an element of risk. The information provided in this section will help you and/or your members make safe and productive use of your **STAR TRAC INSTINCT PECTORAL FLY / REAR DELTOID**.

- ALWAYS consult a physician before beginning any strength-training program. This is particularly important for persons with known health conditions and/or persons that are not familiar with the risks involved with weight training.
- All training sessions should be supervised by trained personnel.
- BE SURE that all warning labels and placards affixed to the **INSTINCT PECTORAL FLY / REAR DELTOID** remain on the unit. DO NOT alter warning labels and placards. BE SURE that each user reads and understands the information shown on all labels and placards (safety, instructional and/or other).
- Instruct all users on the proper use of the **INSTINCT PECTORAL FLY / REAR DELTOID**, as well as those actions that should be avoided.
- Your **INSTINCT PECTORAL FLY / REAR DELTOID** has been designed to accommodate a wide variety of body types. Prior to use, mount the unit and adjust the seat height to ensure comfortable operation of the leverage arm.

To minimize user and/or bystander injury:

- Do not lean the against framework, weight stack or any component, regardless of whether it is dynamic or static.
- Stay clear of all components while in a dynamic state of motion. Keep hands and feet away from cables, belts, cams and pulleys and/or any converging action. The convergence of these transmission-based components can cause serious injury.
- Exercising on free weight and selectorized products should be performed with the assistance of a spotter.

PRODUCT USE AND MAINTENANCE

Repair of the **INSTINCT PECTORAL FLY / REAR DELTOID** should be performed only by authorized persons.

NEVER modify the **INSTINCT PECTORAL FLY / REAR DELTOID** or attempt to make adjustment(s) to, or the repair of, the unit equipment without first calling STAR TRAC Product Support. Always notify authorized personnel to make such repairs.

Instruct all users to report any equipment or training irregularities to supervisory personnel IMMEDIATELY.