

INSPIRATION

STRENGTH™

Designed to Inspire™

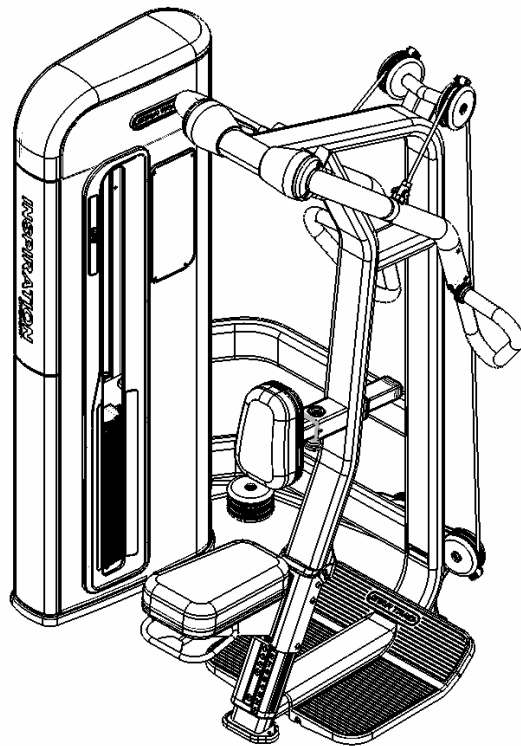

VERTICAL ROW

IP-S3342

INSTALLATION INSTRUCTIONS



expect different™.

Copyright 2009. Star Trac by Unisen, Inc. All rights reserved, including those to reproduce this book or parts thereof in any form without first obtaining written permission from Star Trac.

Every effort has been made to keep this information current; however, periodically, changes are made to the information herein, and these changes will be incorporated into new editions of this publication. All product names and logos are trademarks of their respective owners. Printed in the USA.

INSTALLATION INSTRUCTIONS

REQUIRED TOOLS:

• 2.5MM HEX KEY SOCKET	1	• 13MM OPEN-END WRENCH	2
• 3MM HEX KEY SOCKET	1	• 17MM OPEN-END WRENCH	1
• 4MM HEX KEY SOCKET	1	• 19MM OPEN-END WRENCH	1
• 5MM HEX KEY SOCKET	1	• 13MM SOCKET	1
• 6MM HEX KEY SOCKET	1	• #2 CROSS-HEAD (PHILLIPS) SCREWDRIVER	1
• 8MM HEX KEY SOCKET	1	• TORQUE WRENCH	1

GENERAL NOTES:

- Unless otherwise noted Loctite 242/243 or equivalent thread locker must be used on all threaded fasteners. (Do not use thread locker when a Nyloc nut is used.)
- All Star Trac Strength equipment **MUST** be secured to the floor using either 10mm or 3/8in. (grade 5 minimum) bolts. To accommodate this there are four mounting points inside the weight stack and one in either of the small feet.
- This Installation Instructions Manual must be used in conjunction with the equipment's Owner's Manual. The Owner's manual describes equipment setup and instructs members on how to use it correctly and safely.
- The Vertical Row Machine weighs approximately 330 Kg (728 lbs) when fully assembled and occupies an area 128 cm wide by 116 cm deep. Star Trac recommends the addition of 1-2 people during assembly, and when moving the equipment to its designated point of use.

THREAD LOCKER APPLICATION: Clean all threads and holes, apply no more than 3-4 drops per bolt.

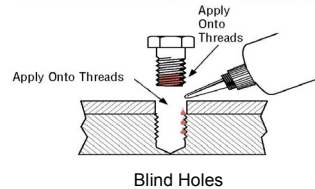
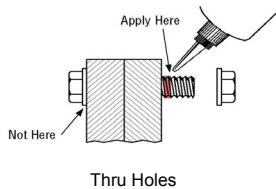

Metric Steel Bolts Torque Specifications

Bolt Size	Thread Pitch	Torque, N-m (lbs-ft)
6mm	1.25	4.5 to 6 (6 to 8)
8mm	1.25	9.5 to 12 (13 to 16)
10mm	1.75	26 to 30 (35 to 40)

- Torque all hardware to values as specified above, unless noted otherwise.
- See Page 11 of this manual for fastener sizing information; for reference only.
- Note: All torque values are in N-m unless otherwise stated.

Should any component not be present or if you have any operational questions, please refer to your owner's manual or on the web @ www.startrac.com. Specifically refer to your Inspiration serial number and model number labeled on your equipment.

PACKAGING REMOVAL:

Carefully remove all packaging materials that wrap the equipment. **DO NOT USE A KNIFE OR BOX CUTTER AS YOU MAY DAMAGE THE EQUIPMENT.** At this time remove any sub-components from the pallet and set aside for later assembly.



REMOVE THE SHROUDS:

1. Using a 4MM hex key socket remove the (M6,30MM,Button Head Bolt) from the rear of the weight stack. Save this bolt as you will need it to re-install later. After the bolt has been removed rotate the black TOP BUMPER towards the front of the weight stack and lift it off. Carefully store the TOP BUMPER for later use.
2. Gripping the top edges of the outside SHROUD lift and remove it from the weight stack. Carefully store the SHROUD for later use.
3. Now repeat step 2 with the inside SHROUD.

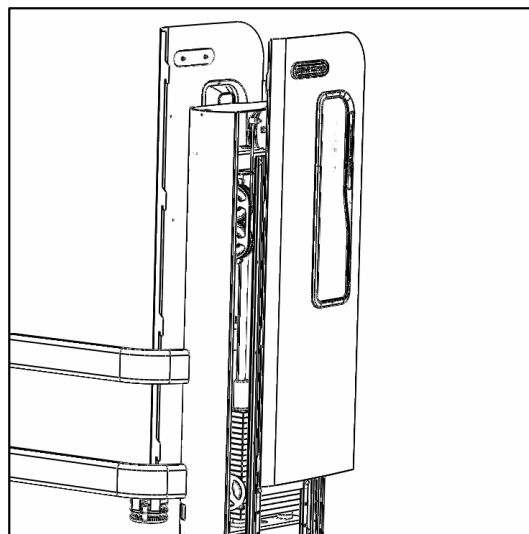
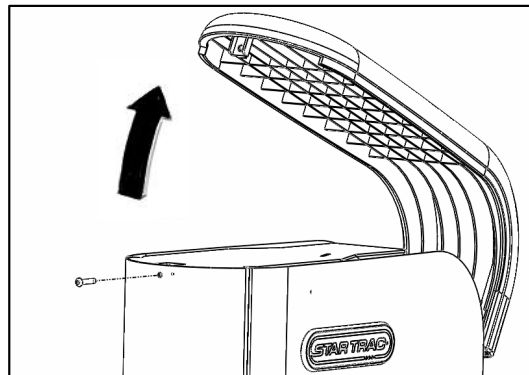

REMOVE FROM PALLET:

1. After removing the shrouds, listed above, remove the bolts securing the equipment to the pallet. The bolts can be found inside the weight stack as shown. There will also be a bolt through each of the small feet.
2. Once all bolts fastening the equipment to the pallet have been removed, carefully slide the equipment off of the pallet and place it in the desired location.

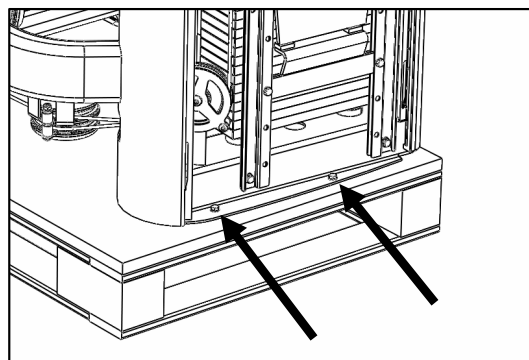

INSTALL PROTECTIVE FEET:

1. Your equipment shipped with a set of PROTECTIVE FEET. Remove the liner from the double sided tape located on the inside edges of the small PROTECTIVE FEET. Tilt the equipment towards the weight stack until the two smaller feet lift off the ground, press the PROTECTIVE FEET into place and set the equipment back on the ground.
2. Remove the liner from the double sided tape located on the inside edges of the large PROTECTIVE FOOT. Now tilt the equipment onto the two small feet lifting the weight stack off the ground, press the large PROTECTIVE FOOT into place and set the equipment back on the ground.

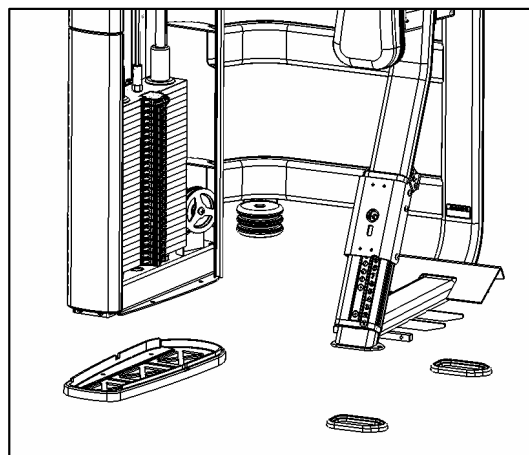

INSTALLING COUNTER BALANCE:

1. The equipment shipped with the arm assembly nearest the weight stack already installed. You will need to install the opposite counter balance, arm, pulleys and attach the end of the cable.
2. Start by Facing the COUNTER BALANCE with the four threaded holes away from the equipment frame as shown. Press the COUNTER BALANCE onto the shaft until both bearings are entirely pressed onto the shaft.
3. After the COUNTER BALANCE has been pressed onto the shaft install and tighten the (M8,25MM,Hex Bolt) & (M8,Washer) using a 13mm socket. The counter balance should now spin freely.

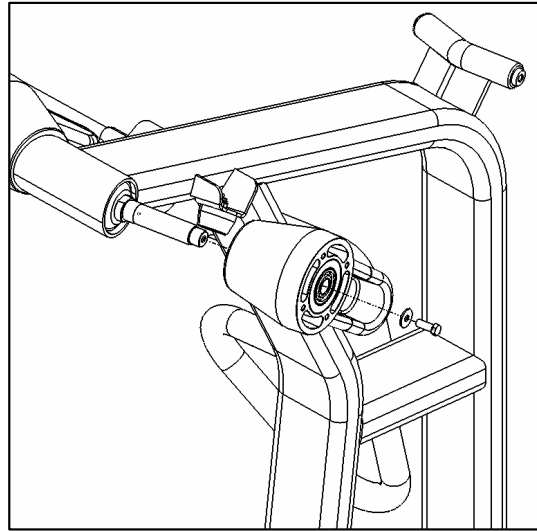

INSTALLING THE ARM:

1. Find the ARM that is marked **A** and align the ARM so that it is positioned pointing in the same direction as the COUNTER BALANCE. Using four (M8,20MM,Button Head Bolts) and four (M8,washers) Install and tighten the ARM using a 5mm hex key socket. as shown. Verify that the arm rotates smoothly.

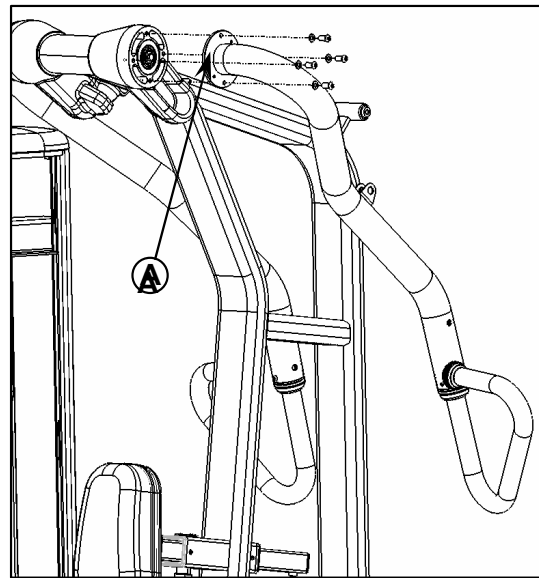

2. Using two (M5,12MM,Button Head Bolts) install the TRIM RINGS as shown, using a 3mm hex key socket. **Torque bolts to 1.1 N-m MAX.**

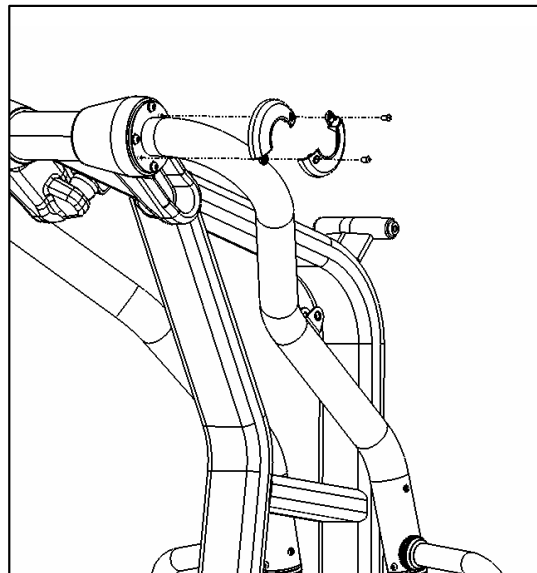

INSTALLING UPPER PULLEYS:

1. Align the PULLEY with the mounting boss on the equipment frame and install a (M10,50MM,Button Head Bolt) and a (M10, Flat Washers.)
2. Orient the cable keeper at an approximate 45° angle with the horizon as shown. Tighten using a 6mm hex key socket.
3. Repeat steps 1 & 2 to install the second UPPER PULLEY on the opposite side of the equipment frame.

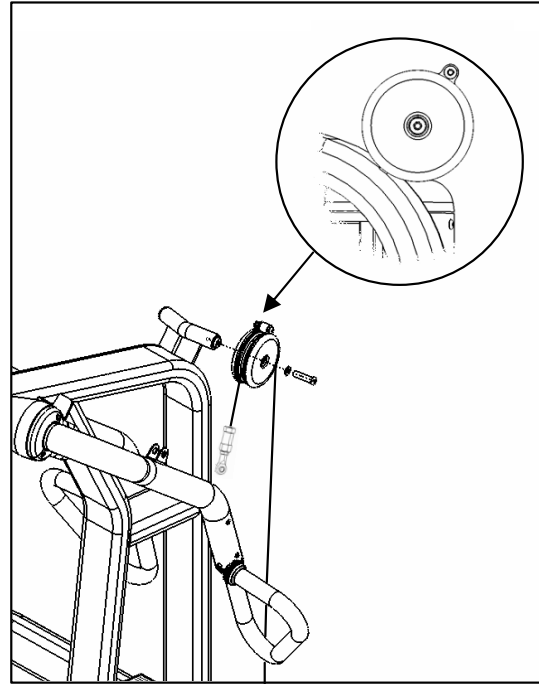

INSTALLING DUAL PULLEYS:

1. Align the DUAL PULLEY bracket with the five M8 threaded inserts and install five (M8,25MM,Button Head Bolts) and five (M8,Flat Washers) and tighten using a 6mm hex key socket.

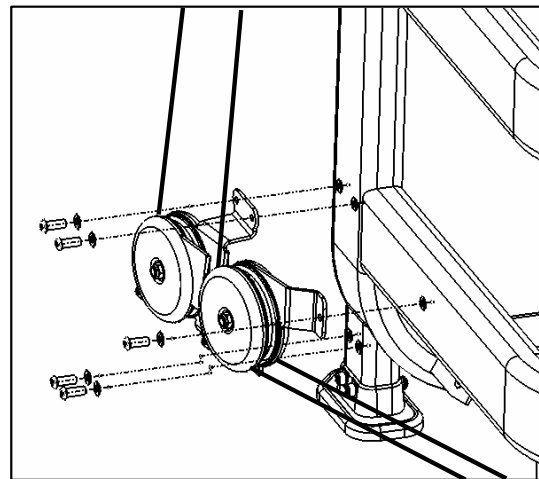

ATTACHING THE CABLE:

1. The CABLE END needs to be attached to the back of the recently installed ARM. Align the CABLE END with the clevis mount located on the rear of the arm, then install a (M10,50MM,Button Head Bolt), two (M10, Hat Washers) and a (M10,Nyloc Nut) as shown. Tighten using a 6mm hex key socket and a 17mm open end wrench.

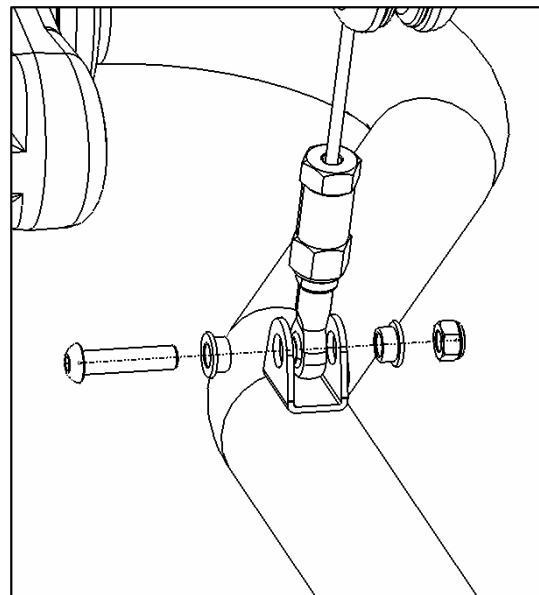

INSTALL FOOT PAD;

1. Install the large rubber covered FOOT PAD and align the four bolt holes, two in front and two in the rear.
2. Install four (M8,25MM,Button Head Bolts) and four (M8,Flat Washers) and tighten.

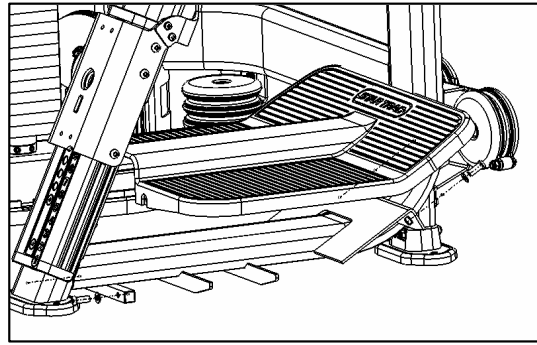

INSTALLING THE SEAT:

1. Align and install the ADJUSTABLE SEAT using four (M8,16MM,Socket Head Bolts) and four (M8,Washers) Tighten using a 6MM hex key. Operate the seat up and down by squeezing the red handle, the ADJUSTABLE SEAT should operate smoothly.

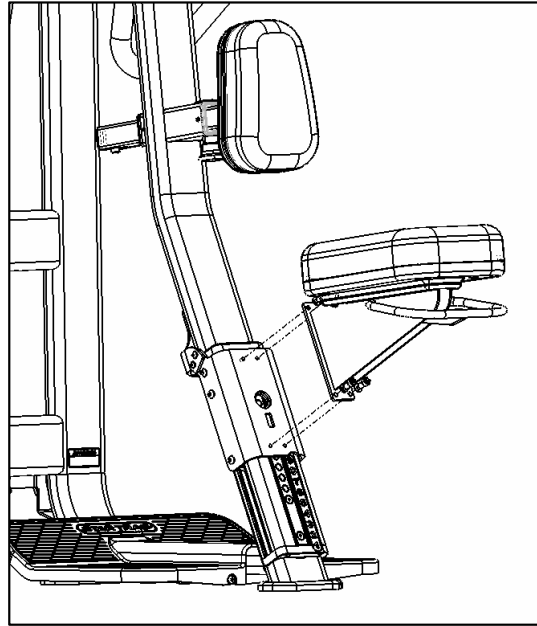

GUIDE ROD LUBRICATION:

1. Use a general purpose LUBRICANT that does not contain Teflon or solvent (such as 3-IN-ONE® oil.) Apply the LUBRICANT to a cotton cloth, then run the cotton cloth up and down the guide rods as needed to apply a thin coat.
2. Also apply oil to the incremental weight guide tracks.
3. Verify that the top plate and incremental plate slide smoothly.

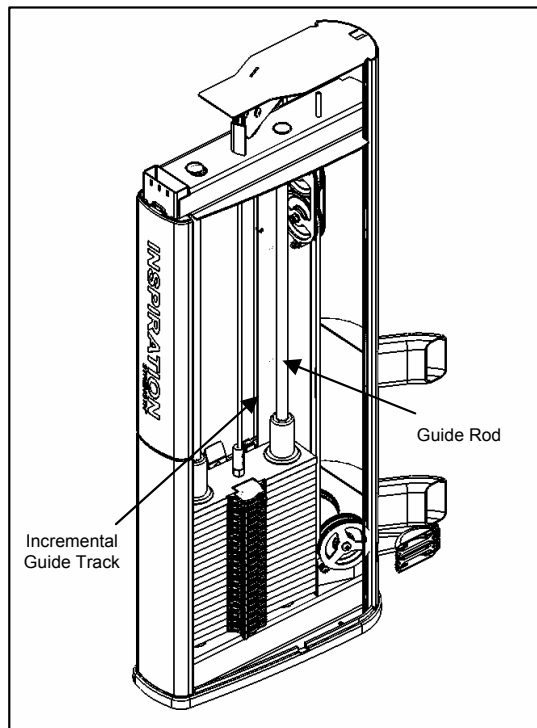

TOP PLATE & CABLE ADJUSTMENT:

1. Engage **LOCKNLOAD™** pin at maximum weight and actuate arm 3 to 4 times to fully seat the weight stacks.
2. Disengage **LOCKNLOAD™** pins and verify that there is no gap between the Top Plate and the lower weight plate. If a gap exists or if there is too much slack on the cable, then the cable tension needs to be adjusted.
3. Using two 13MM open end wrench, loosen the upper M8 Jam Nuts. Adjust cable tension until the Top Plate drops and rests on to the weight stack.
4. Hand tighten the jam nuts and check to make sure the gap is gone. Cable should deflect no more than $\pm 25\text{mm}$ from centerline without raising the Top Plate. Check for smooth **LOCKNLOAD™** pin engagement.
5. Tighten jam nuts.

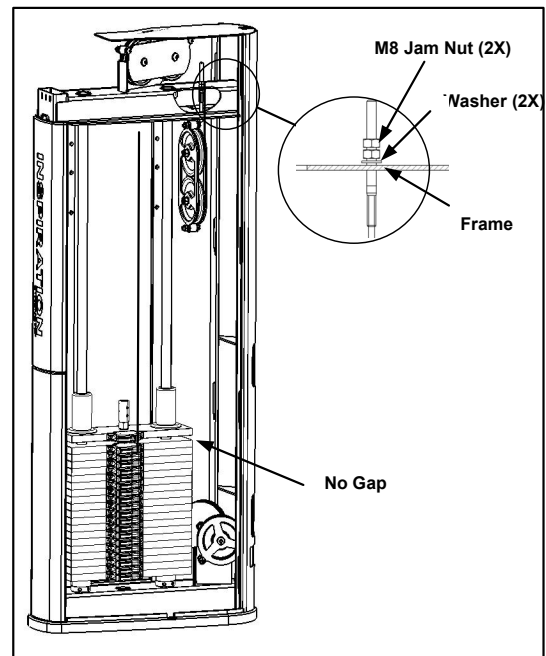

INCREMENTAL WEIGHT ADJUSTMENT:

1. Check to make sure the gap between the TOP PLATE pin and the 20mm hole of the INCREMENTAL WEIGHT plate is 3mm or less when engaged.
2. If gap is greater than 3mm, loosen but do not remove the two BUTTON HEAD SCREWS (M6) using a 4MM hex key.
3. Slide the bracket up or down to create a 3mm gap.
4. Re-tighten the two BUTTON HEAD SCREWS.

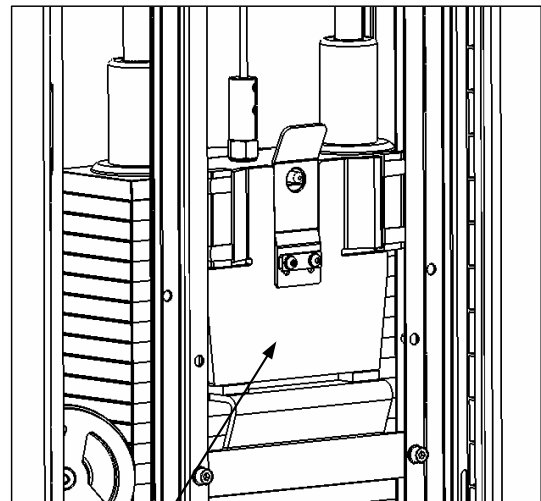
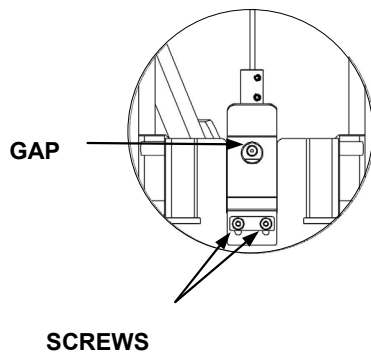

INCREMENTAL WEIGHT PLATE

REAR FOOT ADJUSTMENT:

1. Verify that the equipment is at the desired location and then check to make sure the feet contact the ground and leveled.
2. If the machine rocks or is tippy, adjust rear foot by loosening the two Nyloc nuts using a 13MM open-end wrench and a 6MM hex key.
3. Slide the foot up or down until the machine is leveled.
4. Re-tighten the bolts and nuts.

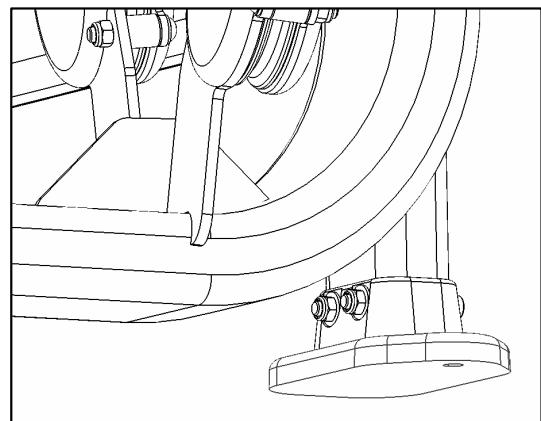

INSTALLING THE SHROUDS:

1. Insert the SHROUDS from the top sliding downward. The SHROUDS have seven hooks for mounting. Before the shroud can be slide down into place, the SHROUD hooks need to be aligned with the corresponding mounting holes found on the weight frame of the equipment. Once the SHROUD hooks are in the mounting holes and the SHROUD has been slid into place verify that the top of the SHROUD is aligned with the top of the weight stack. If the SHROUD is not aligned use the palm of your hand and tap the SHROUD down until it is aligned.
2. Repeat step 1 with the inside shroud and verify alignment.

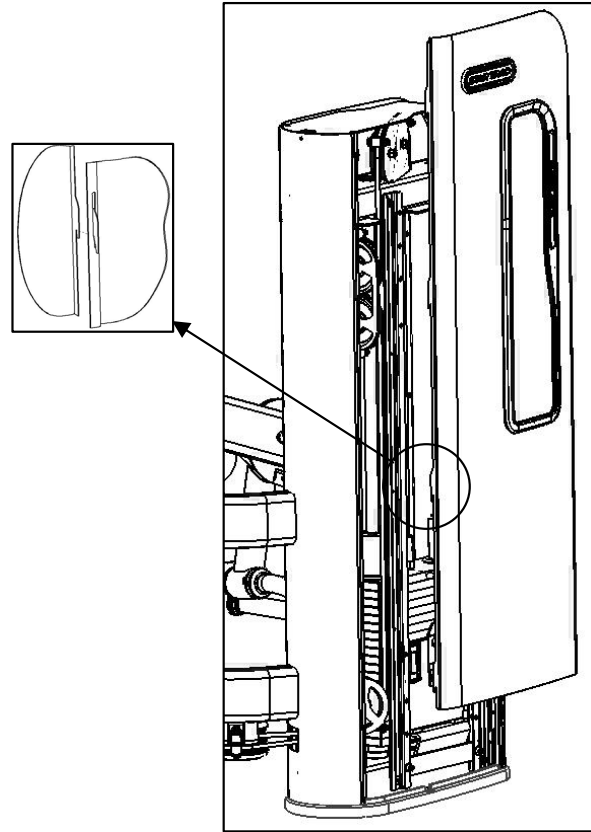

3. After both shrouds have been installed install the black TOP BUMPER by first inserting the two tabs found on the large end of the TOP BUMPER into the equipment main frame. Now rotate the TOP BUMPER down until it is sitting flush on top of the weight frame. Install the (M6,30MM,Button Head Bolt) through the weight frame into the TOP BUMPER as shown. **Torque to 1.1 N-m max. Do not use thread locker on this bolt.**

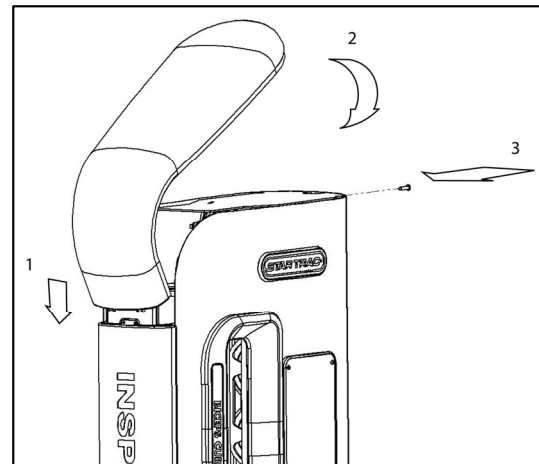

MACHINE CLEARANCE AND SPACING

For the safe operation of Inspiration Strength™ Star Trac recommends that a clearance of 24 inches (60.96cm) be maintained between and behind machines including moving arms and levers. To insure safe entry and exit to each unit a walkway of at least 36 inches (91.44cm) inches is recommended front of, or on the entry side of each machine.

WARNING!



Before using this product, it is essential to read the ENTIRE operations manual and ALL installation Instructions. The Owner's manual describes equipment setup and instructs members on how to use it correctly and safely.



Health related injuries may result from incorrect or excessive use of exercise equipment. Star Trac strongly recommends you to encourage you and your members to discuss their health program or fitness regimen with a health care professional, especially if you or they have not exercised for several years, are over 35, or have known health conditions.

HARDWARE GUIDE

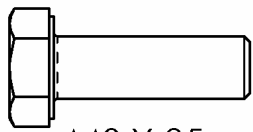

X 2

M8 X 25mm Hex Head Screw

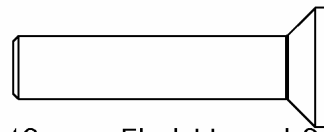

X 2

M8 X 40mm Flat Head Screw

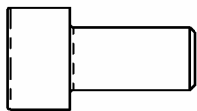

X 4

M8 X 16mm Socket Head Screw

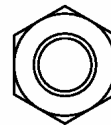

X 2

M8 Nyloc Nut

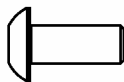

X 2

M5 X 10 Button Head Screw

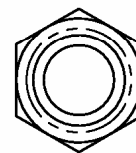
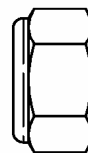

X 2

M10 Nyloc Nut



X 4

M8 X 20mm Button Head Screw

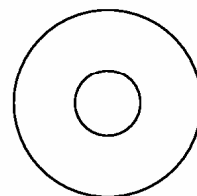

X 2

M8 Washer, Large

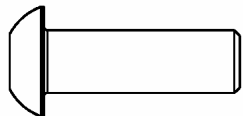

X 9

M8 X 25mm Button Head Screw

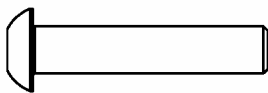

X 1

M6 X 30mm Button Head Screw

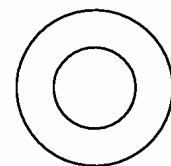

X 2

M10 Washer

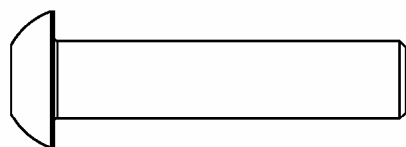

X 1

M10 X 45mm Button Head Screw

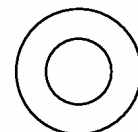

X 18

M8 Washer, 16mm OD

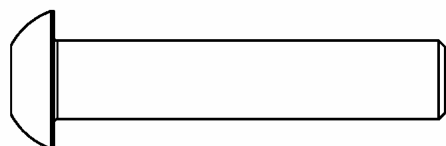

X 2

M10 X 50mm Button Head Screw

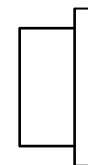
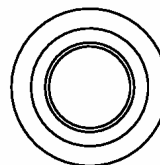

X 29

Hat Washer



expect different™.

STAR TRAC
14410 Myford Road
Irvine, California 92606
Telephone: (800) 228-6635, (714) 669-1660
Fax: (714) 508-3303
www.startrac.com