



**TRUE<sup>®</sup>**

**OWNERS MANUAL**

**600 SERIES**

**700 SERIES**

**725 SERIES**

**750 SERIES**

**COMMERCIAL TREADMILL**

**Manual • Pre-Program • Heart Rate Control • CI-Cardiointeractive**

Thank You  
For Selecting  
A True  
Treadmill



"Our original goal was to build the world's best treadmills, and today we believe we're doing it!"

— Frank Trulaske  
President

In 1981, Frank Trulaske launched True Fitness Technology, Inc. and began manufacturing hand-crafted treadmills.

His team's obsession with quality has propelled True to the top of the industry and has created one of America's oldest, largest and most respected treadmill manufacturers. True's 131,000 square foot facility just outside St. Louis, Missouri, houses the manufacturing plant, engineering laboratory and testing facility.

Over the years, True has designed, developed and fabricated new and cutting-edge components for their complete residential and commercial treadmill line, including innovative frame and suspensions systems.

Intensive quality control standards guarantee excellence in every phase of production, resulting in the finest treadmills available in the marketplace. Today, True is the choice for workouts among beginners, rehab patients and world-class athletes. True treadmills are consistently rated # 1 in smoothness, quietness and softness.

True will continue to develop new and innovative products with *Intelligent Engineering for a long life...yours!*

### SERIAL NUMBER

The serial number of your treadmill is located on a plate next to the power cord on the frame. Record the serial number below.

Serial Number \_\_\_\_\_

**NOTE: The serial number must remain intact for the warranty to remain valid. Please check your serial # ID to verify it has not been tampered with, removed or altered.**



The industry's most modern treadmill manufacturing facility located just outside St. Louis, Missouri. Over 135,000 square feet is dedicated to treadmill research, design and manufacturing.

The engineering and design of True Treadmills is the result of consultation with medical professionals in the cardiac rehabilitation and orthopedic sectors.

Our service and support personnel work in unison with our extensive factory trained dealer network to provide fast, friendly and knowledgeable response to customer needs.

If you have any questions or comments, please call us toll free at 1-800-426-6570

**TRUE**<sup>®</sup>

# Table Of Contents

1-1

## SECTION 1

SAFETY TIPS	1-2
BASICS	1-3
ASSEMBLY	1-4
BELT ADJUSTMENTS	1-4
TREADBELT TENSION	1-5
SAFETY FEATURES	1-5

## SECTION 2

600 CONTROL PANEL DESCRIPTIONS/FUNCTIONS	2-1
700/725 HRC CONTROL PANEL DESCRIPTIONS/FUNCTIONS	2-2
750 CI CONTROL PANEL DESCRIPTIONS/FUNCTIONS	2-3
QUICK REFERENCE OPERATING INSTRUCTIONS	2-4
QUICK REFERENCE OPERATING INSTRUCTIONS WITH EXPRESS KEYS	2-5
MANUAL PROGRAM OPERATING INSTRUCTIONS	2-6
PRE PROGRAM OPERATING INSTRUCTIONS	2-7
PRE-PROGRAM PROFILES	2-8
CARDIOINTERACTIVE AND HEART RATE CONTROL INTRODUCTION	2-9
TRUE HEART RATE CONTROL (HRC) HOW IT WORKS	2-10
CARDIOINTERACTIVE AND HRC TARGET OPERATING INSTRUCTIONS	2-11, 12, 13, 14
CRUISE CONTROL OPERATING INSTRUCTIONS	2-15
CARDIOACTIVE HRC INTERVAL OPERATING INSTRUCTIONS	2-16, 17, 18
HEART RATE CONTROL IMPORTANT POINTS	2-19
PRE-PROGRAM OPERATING INSTRUCTIONS WITH EXPRESS KEYS	2-20
TARGET HEART RATE CHART	2-21
THE F.I.T. FORMULA	2-22, 23, 24

## SECTION 3

CARE AND MAINTENANCE TABLE OF CONTENTS	3-1
MAINTENANCE SCHEDULE	3-2–3-11
EXPLODED DIAGRAMS	3-12–3-17
TROUBLESHOOTING FLOWCHARTS	3-18–3-26
TEST PROCEDURES	3-27–3-32

## SECTION 4

INDIVIDUAL PERFORMANCE CHART	4-1
------------------------------	-----

1-2

## Safety Tips

Congratulations on your purchase of a TRUE treadmill. You have chosen a premium piece of exercise equipment designed to meet your fitness needs.

Before using your treadmill, please review this manual to learn about the unit's features, functions, maintenance procedures, and safe operation.

### SAFETY TIPS:

1. Always use safety key and attach lanyard to your clothing at about waist height.
2. Wear comfortable, good-quality walking or running shoes.
3. Warm-up and cool-down periods are important for a complete workout.
4. Always straddle the belt and allow it to start moving before stepping onto it.
5. Hold the grab bar while adjusting the controls.
6. Keeping your eyes focused straight ahead will help you maintain your balance.
7. Adjust your own speed and grade. Never make adjustments for another person or allow someone else to make adjustments for you.
8. Always allow the belt to stop completely before dismounting. Gradually slowing down also minimizes the sensation of feeling like you are still moving after you stop.
9. Allow space behind treadmill and sides in the event you lose your balance.
10. Always inspect your treadmill to ensure there are no foreign objects obstructing the moving parts.
11. To avoid any possibility of being struck or caught between moving parts, bystanders should not be within reach of the treadmill while it is in motion.
12. For safety reasons and to prevent damage to your treadmill, allow only ONE person at a time on your machine.
13. Never leave unsupervised children near your treadmill.
14. Animals should never be allowed on or near your treadmill.
15. Keep the power cord clear of the incline system. Allow extra slack for inclining the machine. Do not run the power cord under the treadmill.
16. Your treadmill is designed for indoor use only.
17. Never use your treadmill around water or while you are wet. Using the unit around a pool, hot tub or sauna will void the warranty.
18. Do not operate treadmill while using bottled oxygen.

## THE BASICS

Your treadmill is made up of two main sections: the base and the pedestal.

The base of the treadmill consists of a metal frame, a shock-absorbing deck system and a powerful continuous-duty horsepower DC motor. The motor powers a pulley system which moves the running belt over the deck. (See figure 1, page 1-4)

The pedestal mounts on the top of the frame. It places the displays, information readout and touch keys within easy sight and reach. (See figure 1, page 1-4)

## SETTING UP YOUR TREADMILL

Place your treadmill on a clean, level surface. Make sure the electrical cord easily reaches a grounded three-pronged outlet and has enough slack to allow the deck to incline unhindered by the cord. Do not allow the treadmill assembly to rest on the cord. Although your treadmill is designed to operate on most carpeted surfaces, some deeply padded or heavy shag carpets can cause damage to the unit. To prevent damage to your treadmill or carpet, have someone stand on the deck and make sure the treadmill belt doesn't touch the carpet at any point. Your TRUE treadmill is designed for indoor use only. Always keep the control panel out of direct sunlight.

## IMPORTANT ELECTRICAL REQUIREMENTS

Your True treadmill requires a **dedicated 120 VAC 20 amp grounded outlet circuit.** **WARNING: Do not use an extension cord or an ungrounded outlet. The ground helps prevent electrical damage to your treadmill and enhances your safety by preventing shock.**

**A GROUNDED OUTLET IS CRITICAL FOR THE HRC SYSTEM TO FUNCTION PROPERLY.**

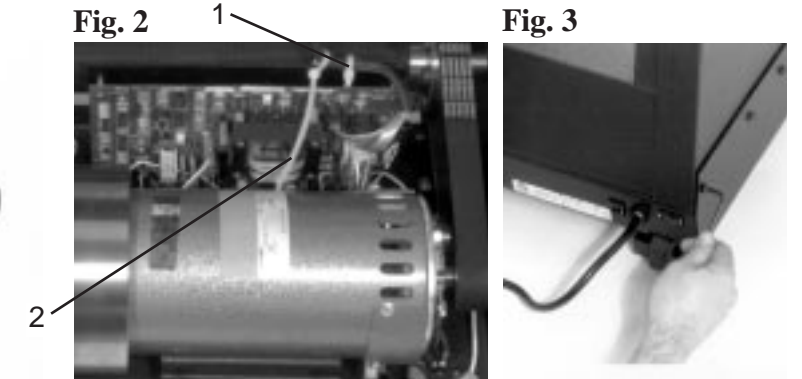
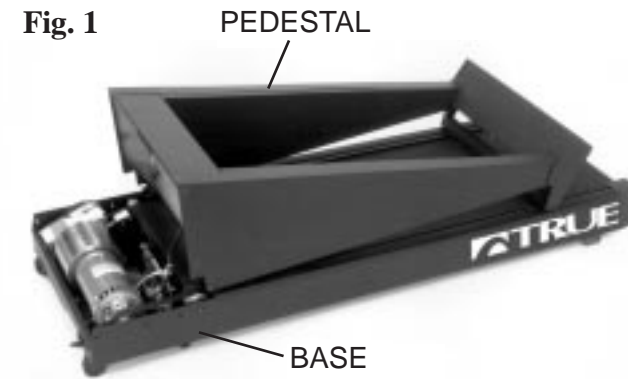

## ASSEMBLY

TRUE treadmills are shipped in two pieces: the pedestal assembly (which includes the control console) and the base.

Instructions for assembling the unit:

1. Remove the protective packaging materials. **NOTE:** Do not lift the treadmill by the motor when removing from carton!
2. Lay pedestal on deck as shown. (Fig. 1)
3. Feed wire harness through reusable wire ties from left to right. (Fig. 2)
4. Tighten wire ties and tuck excess tie down between motor and PWM board. (Fig.2) **NOTE:** Do not cut off excess wire tie. These are reusable.
5. Raise top of pedestal into place.
6. Install three of the enclosed screws with lock washers on each side, then tighten all six screws. (Fig. 3)

## PARTS INCLUDED:

- 1 - ALLEN WRENCH
- 6 - SCREWS
- 6 - STAR WASHERS (LOCK WASHERS)
- 1 - OWNERS MANUAL
- 1 - WARRANTY CARD
- 1 - HEART RATE TRANSMITTER WITH STRAP (HRC MODELS ONLY)

**IMPORTANT:** Do not operate unless all six screws are fastened securely. Be sure screws and lock washers thread into the holes in pedestal. Reverse procedure whenever removing the pedestal. Remove pedestal console only while treadmill is at zero grade and unplugged.

### ELECTRICAL REQUIREMENT:

Your TRUE treadmill requires a **dedicated 120 VAC 20 amp grounded outlet circuit.**

**WARNING:** Do not use an extension cord or an ungrounded outlet. The ground helps prevent electrical damage to your treadmill and enhances your safety by preventing shock. This grounded outlet is critical for the HRC system to function properly. **NOTE:** Units produced for use outside of the U.S.A. will have voltage indicated on the identification tag.

## BELT ADJUSTMENTS

Your treadmill's running belt has been properly aligned at the factory. However, when the treadmill is used on an uneven surface, please follow these instructions:

### PREFERRED METHOD

Level the treadmill by placing shims 1/8" to 3/8" thick under the front wheel and rear shock absorber on one side. **NOTE:** This method will provide extended belt life by keeping both rollers parallel. Adjusting the belt tracking by using the roller bolts will cause the belt to stretch on one side.

**NOTE:** Your authorized True dealer may provide additional support.

## ALTERNATIVE METHOD

1. Stand beside the treadmill, insert the safety key into the bottom of the control panel and follow operating instructions for running the treadmill at 5 mph. (Section 2.5)
2. If the belt is off-center to the right, turn the left roller adjustment bolt counter clock-wise 1/4 turn. If the belt is off-center to the left, turn the left roller adjustment bolt 1/4 turn clockwise. (Figure 1 Detail 1)
3. Let the machine run for several minutes to check the alignment. (Belt alignment does not need to be perfect). If more correction is needed, turn the adjustment bolt 1/4 turn and check again.

## TREADBELT TENSION:

To assure maximum life of the treadbelt, roller and drive motor, make sure the treadbelt tension is set correctly. (Your treadbelt has been properly tensioned at the factory.)



Figure 1

Turn both rear roller adjustment bolts (Detail 1) counter-clockwise until treadbelt just begins slipping when walking on it, then turn both rear roller adjustment bolts clockwise in equal quarter turn increments until treadbelt stops slipping. **NOTE:** Be sure to run on treadbelt to ensure that the treadbelt does not slip while under load.

## SAFETY FEATURES

### PADDED HAND RAIL

The padded hand rail is mounted to the rear of the control console. The bar provides a convenient support to use throughout your workout.

### ON/OFF SWITCH

The on/off switch is located to the right of the power cord on the front of the machine. It completely removes AC power from your treadmill. It is recommended that you use this switch to turn the machine off after each workout.

### CIRCUIT BREAKER

Your TRUE treadmill is protected from overload by a 20 amp circuit breaker that can be reset in the event of a power overload. It is located to the left of the power cord.

### SAFETY KEY AND LANYARD

You can protect yourself from injuries resulting from unexpected loss of balance by attaching the lanyard to your clothing at about waist height when you use your treadmill. When the safety key is detached, your treadmill will not operate.

### REAR ROLLER SHIELDS

Steel guards over the ends of the rear roller prevent towels and other items from getting caught in the running belt.

### FULLY ENCLOSED MOTOR

The motor and flywheel are fully enclosed in a protective metal compartment.

### LOW PROFILE FRAME

To enhance safety, TRUE treadmills are designed to be as low to the ground as possible.

## 600 CONTROL PANEL

### WINDOWS

- DISTANCE:** Indicates miles traveled in .01 mile increments up to 9.99, and .1 mile increments past 10 miles. Can also be set to countdown (See countdown on page 2-7)
- GRADE:** Indicates incline in percent of grade in .5% increments
- TIME:** Indicates elapsed time after pressing start (0-99 minutes and 59 seconds). Can also be set to countdown, (See countdown page 2-7)
- DOT MATRIX**
  1. Instructs during setup.
  2. Provides updated information on progress during workout.
- SPEED:** Indicates mph in .1 increments
- PACE:** Indicates amount of time required to complete 1 mile at that current speed
- CALORIES:** Indicates estimated calories burned. Based on weight, speed, grade and time
- METS:** One MET is the amount of energy your body uses at rest. If a physical activity has an equivalent of six METS, its energy demands are six times that of your resting state

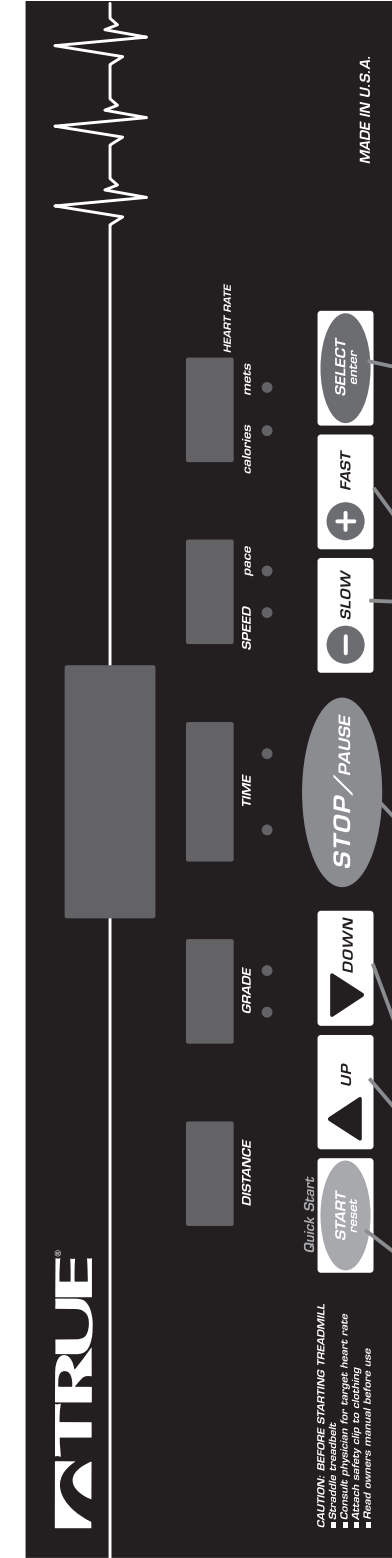

### KEYS

- START/reset:** Starts the treadmill in motion. Also resets distance, time, calories when held for 3 seconds.
- UP/DOWN:** Adjusts the grade at any time during your workout. Sets distance to countdown. Also used to scroll through programs
- STOP/PAUSE:** Stops the treadmill at any point in your workout. Information will be retained unless the safety key is removed or key is held for 5 seconds (Resets to 0)
- SLOW/FAST:** Used to adjust speed in .1 mph increments, to enter weight, other workout parameters, and to set time to countdown
- SELECT/enter:** Used to enter your weight. Also for viewing dual function windows of speed/pace and calories/metabolic rate

# 700, 725 HRC CONTROL PANEL

## WINDOWS

<b>DISTANCE:</b> Indicates miles traveled in .01 mile increments up to 9.99, and 1 mile increments past 10 miles. Can also be set to countdown (See countdown on page 2-5)	<b>GRADE:</b> Indicates incline in percent of grade in .5% increments	<b>TIME:</b> Indicates elapsed time after pressing start (0-99minutes and 59 seconds). Can also be set to countdown, (See countdown page 2-5)	<b>MESSAGE CENTER/DOT MATRIX</b> 1. Instructs during setup. 2. Provides updated information on progress during workout	<b>SPEED:</b> Indicates mph in .1 increments	<b>PACE:</b> Indicates amount of time required to complete 1 mile at that speed	<b>CALORIES:</b> Indicates estimated accumulated calories burned. Based on weight, speed, grade and time	<b>METS:</b> One MET is the amount of energy your body uses at rest. If a physical activity has an equivalent of six METS, its energy demands are six times that of your resting state
---	--	--	--	---	--	---	---

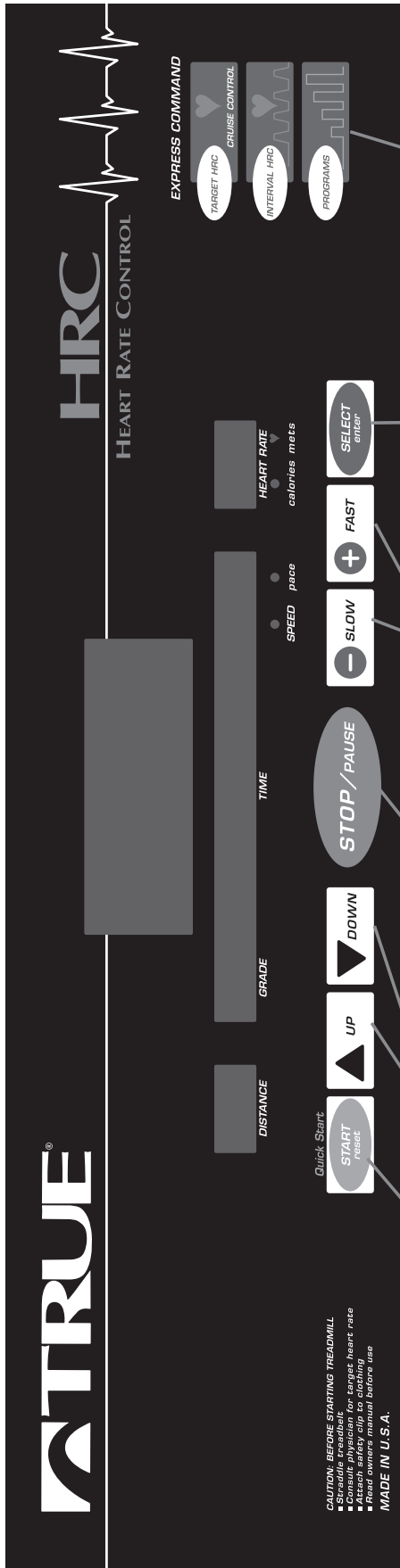

**CAUTION: BEFORE STARTING TREADMILL**  
 ■ Straddle Treadmill  
 ■ Consult physician for target heart rate  
 ■ Read safety manual before use  
**MADE IN U.S.A.**

**EXPRESS KEYS:**  
 Access your favorite workouts. Choose from target HRC workout, cruise control HRC, interval HRC workouts, or pre-programs.

**SLOW/FAST:**  
 Used to adjust speed in .1 mph increments, enter weight, and other workout parameters, and to set time to countdown

**STOP/PAUSE:**  
 Stops the treadmill at any point in your workout

**UP/DOWN:**  
 Adjusts the grade at any time during your workout. Sets distance to countdown, also scroll through programs.

**START/RESET:**  
 Starts the treadmill in motion. Also resets distance, time, and calories when held for 3 seconds

**SELECT/enter:**  
 Used to enter your weight. Also for viewing dual function windows of speed/pace and calories/metabolic rate



## With Express Command Keys

The following is a quick overview of the basic operating features of your True treadmill. While more detailed operating instructions are on the following pages, these quick references will familiarize you with the basic operating procedures needed to get started.

### BASICS:

- Straddle Treadbelt
- Insert Safety Key, attach lanyard to clothing

### HEART RATE CONTROL:

Set Weight Using Keys

Press Press Either or to access HR workout.

Press Edit HR Using Keys

Press Edit Max. Speed Using Keys

Press Edit Time Using Keys

(For Interval HRC There Will Be Several Time Variables To Edit. Total Time, Work Time, Rest Time.)

Press Edit Max. Grade Using Keys

Press

### CRUISE CONTROL

Enter Manual Workout While Wearing Heart Rate Transmitter. (Heart Rate Will Be Displayed In Heart Rate Window.) When You Reach Desired Heart Rate Press

### QUICK START:

(Manual Workout Only)

Press Adjust Speed Using Keys Adjust Grade Using Keys

### PROGRAMS:

Set Your Weight Using Keys

Press Press key to access programs Scroll To Desired Program Using Key

Set Program Level Using Keys (Pre Programs Only)

Press Set Time Using Keys (15:00-99:00 Minutes)

Press

### TO END WORKOUT:

Slow Machine To Below 2 MPH

Using Key

Press Key

600, 700, 725 HRC

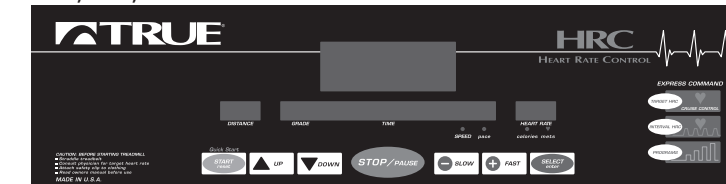

### BASICS

- Straddle Treadbelt
- Insert Safety Key

### QUICK START

(Manual Workout Only)

Press Adjust Speed Using Keys Adjust Grade Using Keys

### BASIC START-UP

- Plug machine into a grounded 120 VAC outlet.
- Turn on the power switch.
- Step onto the treadmill.
- Straddle the treadmill.
- Insert safety key into the console behind the grab bar.

**Caution:** When the safety key is inserted, the treadmill will return to 0% grade. Please keep the area under the treadmill free from obstructions.

- Connect safety lanyard clip to the waist band of your clothing. Do not operate treadmill without safety lanyard clipped to your clothing at about waist height.

The message will read **WGT FAST/SLOW** followed by **PRESS SELECT** **PRESS START**

The time window will display last entered weight. Use to change the weight and press .

### MANUAL MODE

- Message now reads **NEXT UP/DN** followed by **PRESS START**

- Press to get tread belt moving.
- Hold the grab bar and carefully step onto the treadmill and begin walking. It is important to start at a safe speed. It is not recommended to exceed 2.0 mph when starting the treadmill.
- Speed and grade may be adjusted any time during your workout by pressing for speed and for grade.
- **To stop your workout:** Slow machine to below 2 mph by pressing . Press .
- **To reset distance, time, and calories:** (During workout) Press and hold until zeros appear in the time, distance, calorie windows. If not in use, press and hold .
- **Recall of accumulated data:** obtained by pressing the .

**Countdown Feature:** (Time and distance)

Enter weight press

Press again and **ADJ TIME** will appear in message center. Set time using key. Press again and **ADJ DISTANCE** using keys. Press .

**NOTE:** These functions will give you an audible signal and begin counting up when the time or distance has reached zero. The treadmill will continue to move.

600, 700, 725 HRC

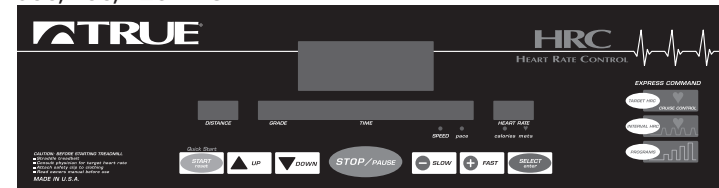

## BASIC START-UP

- Plug machine into a grounded 120 VAC outlet.
  - Turn on the power switch.
  - Step onto the treadmill.
  - Straddle the treadbelt.
  - Insert safety key into the console behind the grab bar.
- Caution:** When the safety key is inserted, the treadmill will return to 0% grade. Please keep the area under the treadmill free from obstructions.

- Connect safety lanyard clip to the waist band of your clothing. Do not operate treadmill without safety lanyard clipped to your clothing at about waist height. The message will read **ADJ WGT FAST/SLOW** followed by **PRESS SELECT**. The time window will display last entered weight. Use **SLOW** **FAST** to change the weight and press **SELECT**.

## PROGRAM MODE

- **NEXT UP/DN** message appears, followed by **EDIT SELECT**. Press **UP** or **DOWN** to access the programs
- Press **UP** and the message will read **HILL INTRVL** followed by **ADJ LVL FAST/SLOW** followed by **PRESS START**.

Scroll to desired program using

**UP** **DOWN** keys.

Select a level using **SLOW** **FAST**

Press **SELECT**

After program and level have been selected, set time using **SLOW** **FAST** keys (15:00-99:00 minutes)

Press **START** to begin

- **Carefully** step onto treadbelt.

700 P

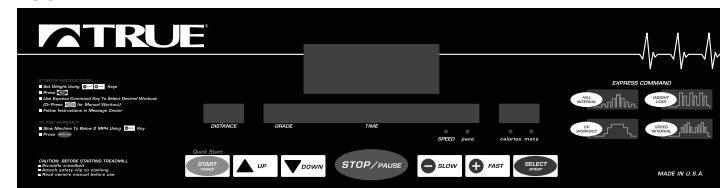

- **To stop your workout:** Slow machine to below 2 mph by pressing **SLOW**. Press **STOP/PAUSE**.
- **To reset distance, time, and calories:** (During workout) Press and hold **START** until zeros appear in the time, distance, calorie windows. If not in use, press and hold **STOP/PAUSE**.
- **To change level during workout:** press and hold **SELECT**. Press **SLOW** **FAST** keys to select new level. After new level is entered press **SELECT**.
- **Recall of accumulated data:** after workout is complete data may be recalled by pressing the **STOP/PAUSE**.

## 700 SERIES P MODELS:

Set Your Weight Using **SLOW** **FAST** Keys

Press **SELECT**

Press Desired Program Key

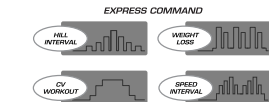

Set Program Level Using **SLOW** **FAST** Keys

Press **SELECT**

Set Time Using **SLOW** **FAST** Keys (15:00-99:00 Minutes)

Press **START**

**NOTE:** All workouts (programs) are able to be set from 15:00 - 99:00 minutes. Default value (if no time entered) is 30:00 minutes. When timer reaches 0:00 it will beep and begin counting up.

**NOTE:** When in run mode user may switch from one workout to the next selected, joining the workout in process at the same time as the previous workout. **EXAMPLE:** Working out in weight loss at the 15:00 mark user pressed CV Workout, computer and readout reflects move to CV Workout and resumes countdown at 15:00.

## HILL INTERVAL WORKOUT

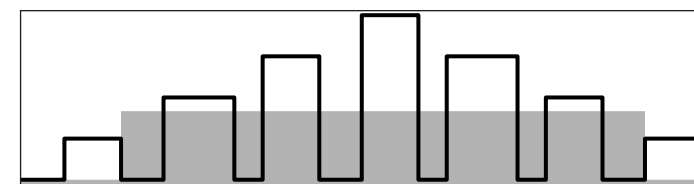

— solid line is the grade  
 ■ screened area is the speed

LEVEL	SPEED (MPH)		GRADE (%)	
	MIN	MAX	MIN	MAX
1	2.0	2.4	1.0	4.0
2	2.2	2.8	1.5	5.0
3	2.6	3.2	2.0	6.0
4	3.0	3.6	3.0	7.0
5	3.4	4.2	4.0	8.0
6	3.8	4.6	5.0	9.0
7	4.0	5.0	6.0	10.0
8	4.4	5.4	7.0	11.0
9	4.8	6.0	8.0	12.0

## WEIGHT LOSS WORKOUT

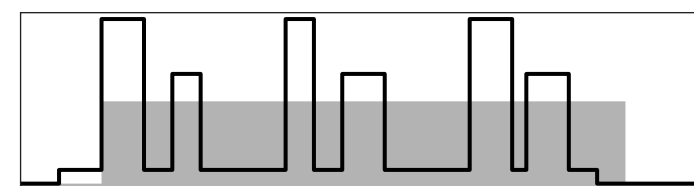

— solid line is the grade  
 ■ screened area is the speed

LEVEL	SPEED (MPH)		GRADE (%)	
	MIN	MAX	MIN	MAX
1	1.4	2.6	0.0	2.0
2	1.6	2.8	0.5	3.0
3	1.8	3.0	0.5	4.0
4	2.0	3.2	1.0	5.0
5	2.2	3.4	1.5	6.0
6	2.4	3.6	2.0	7.0
7	2.6	3.8	2.5	8.0
8	2.8	4.0	3.0	9.0
9	3.0	4.2	3.5	10.0

## CARDIOVASCULAR WORKOUT

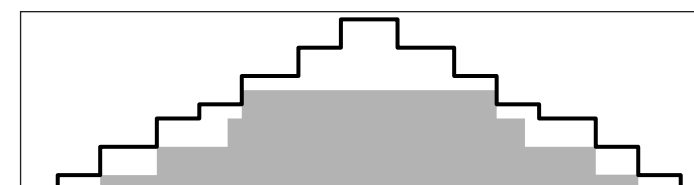

— solid line is the grade  
 ■ screened area is the speed

LEVEL	SPEED (MPH)		GRADE (%)	
	MIN	MAX	MIN	MAX
1	2.0	2.4	0.5	4.0
2	2.2	2.8	0.5	5.0
3	2.6	3.2	0.5	6.0
4	3.0	3.6	1.0	7.0
5	3.4	4.2	1.0	8.0
6	3.8	4.6	1.0	9.0
7	4.0	5.0	1.0	10.0
8	4.4	5.4	1.0	11.0
9	4.8	6.0	1.5	12.0

## SPEED INTERVAL WORKOUT

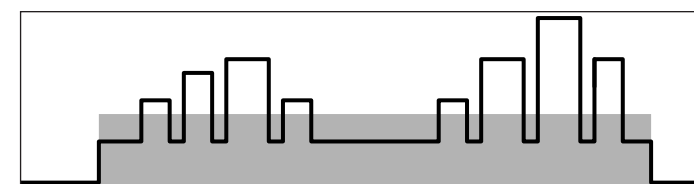

— solid line is the speed  
 ■ screened area is the grade

LEVEL	SPEED (MPH)		GRADE (%)	
	MIN	MAX	MIN	MAX
1	2.0	2.4	2.0	4.0
2	2.2	2.8	3.0	5.0
3	2.6	3.2	4.0	6.0
4	3.0	3.6	5.0	7.0
5	3.4	4.2	6.0	8.0
6	3.8	4.6	7.0	9.0
7	4.0	5.0	8.0	10.0
8	4.4	5.4	9.0	11.0
9	4.8	6.0	10.0	12.0

**INTRODUCTION**

You are now the owner of the most sophisticated Heart Rate Control treadmill available. The TRUE HRC is unique and patented. It accommodates users in rehabilitation to world class athletes, and all those in between. The TRUE HRC treadmill allows you to do a completely hands free heart rate controlled workout using speed, grade or both. The user determines all the key parameters of the HRC workout, including speed, grade, time, and target heart rate.

By training at a specific target heart rate, you can exercise at a more efficient cardiovascular level.

The TRUE HRC system is unique because you can enter the key parameters of your workout, target heart rate, maximum speed, maximum grade, and time, prior to beginning your HRC workout. As you approach your target heart rate, the treadmill software takes over and changes speed and/or grade to keep you near your target heart rate. This gives you a completely "hands free" workout.

**RECOMMENDATIONS**

Before selecting a target heart rate control workout, it is important to use the treadmill for several workouts in the manual mode while monitoring your heart rate.

You can monitor your heart rate during workouts by wearing the heart rate transmitter included with your treadmill. Your heart rate will automatically appear in the lower right hand window, and the heart shaped light will blink to indicate a signal is being received.

After you have spent some time learning how your heart reacts to different levels of speed and grade, you will have a better understanding of how to select the maximum speed and maximum grade required to reach your target heart rate.

**CONSULT YOUR PHYSICIAN TO DETERMINE YOUR TARGET HEART RATE.****WORKOUT GUIDELINES****1. Target Heart Rate Training**

Preset your target heart rate, maximum speed, maximum grade, and time of workout. These are time-based workouts. The distance traveled will vary depending on speed.

**2. Interval Heart Rate Training**

Interval heart rate training takes your workout to an even higher level. Interval training allows you to program periods of rest between periods of work. For each workout, you enter target heart rate, maximum speed, maximum grade, duration of workout, and duration of work and rest intervals. These are time-based workouts. The distance traveled will depend on your speed.

**3. Cruise Control**

Manual workout with heart rate transmitter. When you reach desired heart rate, press cruise control key and it's hands-free.

**4. Manual Workout:**

This is a completely user controlled workout. You control the speed and the grade throughout your workout. Your heart rate may be monitored during this workout, but it is not heart rate controlled.

**5. Programs:**

There are 4 preprogrammed workouts:

- Hill Intervals
- Weight Loss workout
- Cardiovascular workout
- Speed Interval workout

Each workout has 9 levels of intensity. The treadmill controls both the speed and grade.

These are not heart rate controlled, but will monitor heart rate.

Duration of programs are 15:00 to 99:00 minutes.

**6. To Increase Workload in Heart Rate Control:**

To raise your heart rate in the HRC mode, speed will always increase until maximum speed is attained, followed by grade (if grade is used in the workout).

**7. To Decrease Workload in Heart Rate Control:**

To lower heart rate in the HRC mode, grade will always decrease until zero grade is reached, followed by speed (if grade is used in the workout).

**8. Speed Change:**

Each change in speed is in .1 MPH increments.

**9. Grade Change:**

Each change in grade is in .5% grade increments.

This unique, simple, and safe system is easy to use and understand.

The user first sets their personal maximums for **both speed and grade**. This allows the user to customize and create a variety of workouts. By setting personal maximums for speed and grade, the user is provided safe workouts that fit their capabilities. Once this data is entered, along with target heart rate and workout time, the user is ready to start their Heart Rate Control workout.

The initial stage of the Heart Rate Control workout is the warm-up stage and allows the user the flexibility to adjust their speed or grade at anytime. The warm-up stage is not predetermined by the amount of time input prior to workout, and the user may take as much time as they wish to approach their target heart rate. The warm-up stage ends when the user's heart rate is ten beats below the pre-set target heart rate.

At this point, the user enters the Heart Rate Control stage, and the treadmill takes control of both the speed and grade (hands free).

The treadmill software gradually increases the user's heart rate to within 10 beats of the target heart rate.

In the situation where workload needs to be increased in order to elevate the heart rate, the speed will be increased first in 1/10 mph increments.

If needed, the speed will continue to increase up to the pre-set maximum. If the user still requires additional workload to raise the heart rate, the grade will be raised in .5% increments up to the maximum pre-set grade (unless zero grade was entered).

Conversely, whenever the workload needs to be reduced in order to lower the heart rate, the grade is always reduced first. The grade will be reduced to zero (if required), before speed is reduced.

**EXAMPLES OF HOW HRC CAN WORK FOR YOU:****Example #1:**

A user who physically cannot walk over 2.5 mph can safely use heart rate control by entering maximum speed of 2.5 in a Heart Rate Control workout.

**Example #2:**

A runner can run up to a maximum speed of 10 mph, without hills, by entering a maximum speed of 10 mph and a maximum grade of 0%.

**Example #3:**

A walker enters a maximum speed of 4.0 mph and a maximum grade of 6%. The walker is limited to a maximum speed of 4.0 mph and grade will be used if required to elevate the heart rate up to a maximum of 6%.

700, 725 HRC

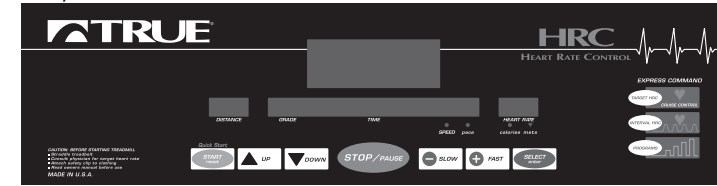

## OPERATING INSTRUCTIONS

Before beginning operation of the treadmill in Heart Rate Control, you must first attach the heart rate transmitter around your chest. The radio frequency transmitter strap provided with your treadmill should be worn directly against your skin, 1-2 inches below the pectoral muscles/breast line. Women should be careful to place the transmitter below their bra line. Initially, the transmission signal for heart rate may be erratic or non-existent. Perspiration on your skin is necessary for proper transmission. In most cases, by the end of your warm up, transmission becomes consistent and accurate. If not, saline solution should be used to moisten the sensors on the back of the strap. The Heart (♥) LED will flash, showing that the heart rate signal is received.



Women should be careful to place the transmitter below their bra line. Initially, the transmission signal for heart rate may be erratic or non-existent. Perspiration on your skin is necessary for proper transmission. In most cases, by the end of your warm up, transmission becomes consistent and accurate. If not, saline solution should be used to moisten the sensors on the back of the strap. The Heart (♥) LED will flash, showing that the heart rate signal is received.

## BASIC START-UP

- Plug machine into a grounded 120 VAC outlet.
- Turn on the power switch.
- Step onto treadmill.
- Straddle treadbelt.
- Insert safety key into the console behind the grab bar.

**Caution:** When the safety key is inserted, the treadmill will return to 0% grade. Please keep the area under the treadmill free from obstructions.

750 CI

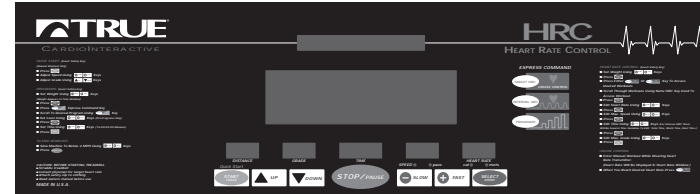

- Connect safety lanyard clip to the waistband of your clothing. Do not operate treadmill without safety lanyard clipped to your clothing at about waist height. The message will read **WGT FAST/SLOW** followed by **PRESS SELECT/PRESS START**. The time window will display last entered weight. Use **SLOW** **FAST** to change the weight and press **SELECT**.

## ALL TRUE HEART RATE CONTROL WORKOUTS CONSIST OF THREE STAGES:

1. Warm -up Stage
2. Target Heart Rate Control Stage
3. Cool Down Stage

## TO USE TARGET HRC WORKOUT

Press the **TARGET HRC** **HEART RATE CONTROL** button.  
 Message Reads **EDIT/SELECT**  
**NEXT UP/DN**  
**PRESS START**-only when ready to begin the workout.

**NOTE:** Check the target heart rate each time you use target heart rate training workout.

Press **SELECT** (In the window labeled heart rate the last edited heart rate will appear.)  
 The message will read:  
**ADJ TARGET + -**  
**NEXT-SELECT**  
**PRESS START.**  
 Using **SLOW** **FAST**, edit heart rate.

Press **SELECT** enter.  
**ADJ MAX SPEED + -**  
**NEXT-SELECT**  
**PRESS START.**  
 Using **SLOW** **FAST**, enter your desired maximum speed.

Press **SELECT**.  
**ADJ TIME + -**  
**NEXT-SELECT**  
**PRESS START.**  
 Using **SLOW** **FAST**, enter your desired time at target heart rate.

Press **SELECT**.  
**ADJ MX GRD + -**  
**NEXT-SELECT**  
**PRESS START.**  
 Using **SLOW** **FAST**, enter your desired maximum grade.

Press **START** to begin your workout.

**NOTE:** If you accidentally press **SELECT** again, the HEART RATE window will flash. Press **START** to begin your workout.

The message will read:  
**STARTING 3**  
**STARTING 2**  
**STARTING 1**  
**ADJ SPEED + -**  
**ADJ GRADE + -**  
**WARM UP**  
**TARGET XXX**

## WARM UP STAGE

The treadmill will operate in the manual mode during the warm-up stage so you can control both speed and grade. It is important that you start at a low level of perceived exertion and gradually increase your work load over several minutes until you approach your target heart rate. This allows your body to adapt to your workout. Increasing work load gradually will allow you to enter the heart rate control stage without overshooting your target.

**NOTE: Warming up too fast may cause you to overshoot your target.** If this occurs it may take several minutes before the computer software can control your heart rate. You may overshoot and undershoot your target for several minutes until control is achieved.



Wear the heart rate transmitter provided with your treadmill directly against your skin, 1-2 inches below the pectoral muscles/breast line. Initially the transmission signal for heart rate may be erratic or non-existent. Perspiration on your skin is necessary for proper transmission. The Heart "♥" LED will flash, showing that the heart rate signal is received.

**Warm-up Stage Instructions:** Using **FAST**, gradually increase speed to a comfortable walk. If you have entered a maximum grade in your workout, you may increase grade gradually by using **UP**. Remember, warm up slowly! Continue increasing speed and/or grade to gradually increase your heart rate. You may only increase speed and grade to the preset maximum values entered.

When your heart rate is within 15 beats from the target, the message center will read

**APPROACHING TARGET XXX**

**NOTE:** If while you are warming up you feel that your selected target is too high or too low, you can edit your target heart to a new value as follows:

Press . Using , edit heart rate (only 5 beat changes are permitted when editing target down).

Press  enter to set new heart rate target. Continue to warm up. Do this only while display is flashing or the software may exit you from heart rate control.



**HEART RATE CONTROL STAGE**

Heart Rate Control Stage Instructions: When your heart rate is 10 beats away from your target, the message center will read:

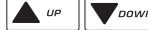

**BEGINNING  
TARGET HRC  
HANDS FREE**

The computer software takes control of the treadmill at this point, allowing HANDS FREE operation. The time window will reset and begin descending from the time you originally entered in the setup of the workout parameters. The treadmill now controls all speed and grade changes. The treadmill will gradually continue to increase your workload until you reach your selected target heart rate. When your heart rate is at plus or minus 2 beats, the message center will read:

**AT TARGET**

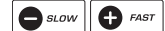
**NOTE:** Do not touch the . Touching any key except  or  will immediately exit you from heart rate control and begin your cool down stage. As your heart rate increases or decreases from your target, the treadmill will automatically make adjustments to speed and/or grade to keep your heart rate near your selected target. If your speed or grade reaches your preset maximums, **MAX SPEED** or **MAX GRADE** will be displayed.

**NOTE:** To edit your target heart rate to new values while in heart rate control stage: Press . (The target value will be displayed, **TARGET XXX, ADJ TARGET + -**). Using  edit heart rate. (only 5 beat changes are permitted when editing target down).

Press  to set new target heart rate. The treadmill will now adjust the work load to bring you to your new target. Do this only while display is flashing or the software may exit you from heart rate control. To end your workout before the time you previously selected, press .

**COOL DOWN STAGE**

Cool Down Stage Instructions: When time is elapsed and the HRC stage is finished, the message center will read:

**COOL DOWN** (audible signal) followed by  
**AVG HEART RATE XXX**  
**DIST XXX**  
**CALS XXXX**  
**TIME XX:XX**  
**COOL DOWN**

**NOTE:** Your accumulated average heart rate, distance, calories, and time are summarized.

**COOL DOWN** will remain in the message center to remind you that you are in the cool down stage. There will be an immediate 50% MET reduction in your work load when you enter the cool down stage. The treadmill will now operate in the manual mode. The time will reset to 00:00 and begin to ascend. You will be in complete control of all speed and grade changes. It is recommended that you spend an equal amount of time in the cool down stage as you did in the warm up stage, or a minimum of at least two minutes. Press  when you are finished!

**NOTE:** Workout totals of average heart rate, distance, calories and time, will appear in message at the end of your workout. If you prematurely end your workout during the HRC stage, you will enter the cool down stage and your workload will remain constant. You may then manually adjust speed and grade.

**NOTE:** Accumulated data of average heart rate, distance, calories, and time is displayed each time  is pressed

### CRUISE CONTROL HEART RATE CONTROL

Here's the simplest way to enter target heart rate training. While in manual workout on all HRC, CI models, you can easily enter Target Heart Rate Control by simply pressing the Target Heart Rate Express Key.

- Secure heart rate transmitter around chest. (see page 2-10.)
- Step onto treadmill.
- Straddle treadbelt.
- Insert safety key into the console behind the grab bar.

**Caution:** When the safety key is inserted, the treadmill will return to 0% grade. Please keep the area under the treadmill free from obstructions.

Connect safety lanyard clip to the waistband of your clothing. Do not operate treadmill without safety lanyard clipped to your clothing at about waist height.

The message center will read **WGT FAST/SLOW** followed by **PRESS SELECT/PRESS START**

The time window will display last entered weight. Use   to change the weight and press .

Press .

Begin manual workout, heart rate will be displayed as it is picked up. When you reach desired heart rate press  (cruise control).

You are now hands-free in target heart rate control.

**NOTE:** To change target press .

You are now in full manual control.

Work to desired target heart rate press .

To end workout press .

- To increase your heart rate while in the HRC mode, the speed will always increase until the maximum speed is attained, then the grade will begin to increase.
- To lower heart rate in the HRC mode, grade will always decrease first, followed by speed.
- If you enter the HRC stage, below 5mph, the speed you enter will be the maximum speed of your workout. i.e.: If you like to walk at a maximum speed of 3.8 mph, you should enter HRC at 3.8 mph.
- If you enter the HRC stage above 5 mph, you will have an additional 1 mph of speed. i.e.: If you enter HRC at 6 mph, your maximum attainable speed in the HRC stage will be 7 mph.
- If at any time you enter the HRC stage with grade, you will have an additional 4% of grade available in the HRC stage. i.e.: If you enter the HRC stage at 1% grade your maximum attainable grade will be 5%.
- If you do not enter the HRC stage with grade, no grade will be available during the HRC stage of your workout. Only speed will be used to control your heart rate.

### EXAMPLES OF WALKING WORKOUTS:

1. Enter HRC at 3.5 mph and 4% grade to allow a maximum speed of 3.5 mph and 8% grade.
2. Enter HRC at 4.2 mph and 6% grade to allow a maximum speed of 4.2 mph and 10% grade.

### EXAMPLES OF RUNNING WORKOUTS:

1. Enter HRC at 6 mph and 0% grade to allow a maximum of 7 mph and 0% grade.
2. Enter HRC at 5 mph and 2% grade to allow a maximum of 6 mph and 6% grade.

### ALL TRUE HEART RATE CONTROL WORKOUTS CONSIST OF THREE STAGES:

1. Warm -up Stage
2. Target Heart Rate Control Stage
3. Cool Down Stage

### TO USE HRC INTERVAL WORKOUTS

Interval Workouts offer variety and help you attain higher levels of conditioning in a shorter period of time.

It is recommended that you do not do an interval workout until you have used this treadmill on a regular basis and have a working knowledge of your target heart rate and fitness level.



### BASIC START-UP-MODEL

- Plug machine into grounded 120 VAC outlet.
- Turn on the power switch
- Step onto the treadmill
- Straddle the treadbelt.
- Insert safety key into console behind the grab bar.

**Caution:** When the safety key is inserted, the treadmill will return to 0% grade. Please keep the area under the treadmill free from obstructions.

- Connect safety lanyard clip to the waistband of your clothing. Do not operate treadmill without safety lanyard clipped to your clothing at about waist height.



Message will read **WGT FAST/SLOW** followed by **PRESS SELECT/PRESS START**

Last entered weight will be displayed. Use   to change the weight and press .

Press .



Press  (In the window labeled heart rate the last edited heart rate will appear.)

**ADJ TARGET + -** will appear in the message followed by **NEXT-SELECT/PRESS START.**

Press   to change your target heart rate.

Press . The message will read:

**ADJ MX SPD + -**  
**NEXT-SELECT**  
**PRESS START**

Press   to enter your desired maximum speed.



Press . The message will read:

**ADJ TIME + -**  
**NEXT-SELECT**  
**PRESS START**



Press   to enter your desired time.

Press . The message will read:

**ADJ WORK + -**  
**NEXT-SELECT**  
**PRESS START**



Press   to enter your desired work interval time. You may adjust work interval from :30 seconds to 3 minutes in :05 second segments. Press . The message will read:

**ADJ REST + -**  
**NEXT-SELECT**  
**PRESS START**

Press   to enter your desired rest interval time. You may adjust rest interval from :30 seconds to 3 minutes in :05 second segments. Press .

The message will read:

**ADJ MX GRD + -**  
**NEXT-SELECT**  
**PRESS START**

Press   to enter your desired maximum grade.

Press  to begin workout.

**NOTE:** If you accidentally press  again, the **HEART RATE** window will flash.

Press  to begin your workout.

The message will read:

**STARTING 3**  
**STARTING 2**  
**STARTING 1**  
**ADJ SPEED + -**  
**ADJ GRADE + -**  
**WARM UP**  
**TARGET XXX**

**WARM-UP STAGE**

Warm-up Stage Instructions: The treadmill will operate in the manual mode during the warm up stage so you can control both speed and grade. It is important that you start at a low level of perceived exertion and gradually increase your work load over several minutes until you approach your target heart rate.

This allows your body to adapt to your workout. Increasing work load gradually will allow you to enter the heart rate control stage without overshooting your target.

**NOTE: Warming up too fast may cause you to overshoot your target.** If this occurs it may take several minutes before the computer software can control your heart rate. You may overshoot and undershoot your target for several minutes until control is achieved.

Wear the heart rate transmitter provided with your treadmill directly against the skin 1-2 inches below the pectoral muscles/breast line. Initially the transmission signal for heart rate may be erratic or non-existent.

Perspiration on your skin is necessary for proper transmission. The Heart "♥" LED will flash, showing that the heart rate signal is received.

**NOTE: If while you are warming up you feel that your selected target is too high or too low, you can edit your target to a new value as follows:**

Press or

(The target value message will appear, **TARGET XXX**). Using , edit heart rate (only 5 beat changes are permitted when editing target down).

Press or to set new heart rate target.

Continue to warm up. Do this only while display is flashing or the software may exit you from heart rate control.

**Warm-Up Stage Instructions:** Using gradually increase speed to a comfortable walk. If you have entered a maximum grade in your workout, you may increase grade gradually by using . Remember, warm up slowly! Continue increasing speed and/or grade to gradually increase your heart rate. You may only increase speed and grade to the preset maximum values entered.

When your heart rate is within 15 beats from the target, the message center will read **APPROACHING TARGET XXX**

**HEART RATE CONTROL**

Heart Rate Control Stage Instructions: When your heart rate is 10 beats away from your selected target heart rate, the message center will read:

**BEGINNING TARGET HRC HANDS FREE.**

The computer software will take control of the speed and grade at this point to allow **HANDS FREE** operation. By taking control before you actually reach your target heart rate, the computer reduces the chances of overshooting your target heart rate.

**NOTE: Do not touch the** . Touching any key except or will immediately exit you from heart rate control and begin your cool down stage.

The treadmill will now control all speed and grade changes. The treadmill will gradually continue to increase your workload until your heart rate reaches your selected target.

When your heart rate is at the selected target, the message will read: **AT TARGET**

The message will then read **WORK INT XX:XX**. The time will decrease from the work interval time you entered. When you reach zero, the message will read **REST INT XX:XX**. The time will decrease from the rest interval time you entered.

**700/725 HRC NOTE:** additional displayed data include: **HR REMAIN XX:XX** (total time remaining at target heart rate), this message follows both the work interval and rest interval display.

**XX:XXW** (displayed in time window) time remaining in work interval. **XX:XXR** (displayed in time window) time remaining in rest interval.

**NOTE:** Mets and pace is displayed briefly in message center after target message.

As your heart rate increases or decrease from your target, the treadmill will automatically make the adjustments to speed and/or grade to keep your heart rate near your selected target only while you are in the work interval.

Interval Training is one of the fastest ways to increase cardiovascular fitness. The treadmill will monitor your heart rate and adjust the speed and/or grade while in the work interval. When you enter the rest interval, there will be a **50% MET** reduction. Your work level will remain the same throughout the rest period to allow your heart rate to decrease. Your heart rate will be monitored during this time, but there will be no adjustment to speed or grade in the rest interval.

When you return to the work interval, your speed will return to a calculated average of the speeds and/or grades which were used in the previous work intervals. Your speed and/or grade may increase or decrease while you are in your work interval. This averaging of speed and/or grade enables you to return to a work level which will bring you near your selected target heart rate.

**NOTE:** If you feel that your selected target is too high or too low, you can change your target heart rate as follows, when you are in Heart Rate Control. Press . The target value message will appear:

**TARGET XXX**  
**ADJ TARGET + -**

Using , change your target heart rate. Only 5 beat changes are permitted when editing target while in Interval Workouts. Press to set new heart rate target. The treadmill will now adjust the work load to bring you to your new target. Do this only while the display is flashing or the software may exit you from Heart Rate Control. In Interval Training it may take a few work intervals to bring you to your new selected target heart rate.

To end your workout before the time you previously selected, press .

**COOL DOWN STAGE**

Cool Down Stage Instructions: When the time is elapsed and the HRC stage of your workout is finished, the message center will read:

**COOL DOWN** (audible signal) followed by **DIST XXX**  
**CALS XXXX**  
**TIME XX:XX**  
**COOL DOWN.**

**COOL DOWN** will remain in the message center to remind you that you are in the cool down stage.

There will be an immediate **50% MET** reduction in work load when you enter the cool down stage. The treadmill will now operate in the manual mode. The time will reset to 0 and begin to ascend. You will be in complete control of all speed and grade changes. It is recommended that you spend an equal amount of time in the cool down stage as you did in the warm up stage or, a minimum of at least 2 minutes. Press when you are finished!

**NOTE:** Workout totals of average heart rate, distance, calories and time will appear in the message center at the end of your workout. If while in the HRC stage you prematurely end your workout, you will enter the cool down stage and your work load will remain constant. You may then manually adjust speed and grade.

- The Heart Rate Monitor strap provided with your treadmill should be worn directly against your skin, 1-2 inches below the pectoral muscles/breast line. Initially the transmission signal for your heart rate may be erratic or non-existent. Perspiration on your skin is necessary for proper transmission. In most cases, by the end of your warm-up, transmission becomes consistent and accurate. If not, saline solution should be used to moisten the sensors on the back of the strap. Women should be careful to place the transmitter below their bra line. If the transmitter strap is adjusted or moved while exercising, communication may be affected.
  - If communication is lost for 30 seconds, the treadmill will automatically shut off. It is important to keep the transmitter adjusted properly.
  - The transmitter emits a fairly weak signal to the receiver, so interference from more powerful airwaves (everything from other exercising equipment to airplanes) is not uncommon. The good news is that interference is usually quite brief. If you continue to have intermittent heart rate display problems, consult your local service technician. The problem may be with the transmitter batteries.
  - Oxygen intake directly affects your heart rate. To prevent your heart rate from spiking up, maintain a constant rate of oxygen intake. Maintaining a fluid motion while walking or running and refraining from talking helps to keep your heart rate from spiking.  
**Note: Talking while in the HRC stage will cause your heart rate to rise independent of your workload and cause the software to make unnecessary changes. This will cause inappropriate speed and/or grade changes, and affect the efficiency of your HRC workout.**
  - A grounded outlet is critical for the HRC system to function
  - If erroneous heart readings are displayed above the target selected, you can pull the transmitter portion away from your chest for several seconds. This will keep you from exiting HRC.
  - Two users wearing the same kind of transmitter at the same time, in close proximity, may cause false heart rate display readings.
  - Use only the transmitter provided with your **TRUE HRC** Treadmill.
  - Use dedicated 120 VAC, grounded outlet to help prevent interference.
- Your **TRUE HRC** Treadmill is designed to meet the needs of both walkers and runners by adjusting speed and grade accordingly:
- To raise your heart rate in the HRC stage, speed will always increase first, until you reach your maximum speed, followed by grade (if grade is used in the workout).
  - To lower your heart rate in the HRC stage, grade will always decrease first, until you reach 0 grade, followed by speed (if grade is used in the workout).
  - Each change of speed is .1 MPH increments.
  - Each change of grade is .5% grade increments.
- ### HEART RATE SAFETY PARAMETERS
- Your **TRUE HRC** Treadmill computer software is programmed with the following safety parameters:
- If your heart rate exceeds your target by 12 beats, there will be a 30% reduction in work load to reduce your heart rate.
  - If your heart rate exceeds your target by 20 beats, the unit will automatically shut off as a precautionary measure. (Be cautious when selecting your target heart rate so the 20 beat variance will not exceed your maximum heart rate as determined by your physician).
- Heart Rate Control Patent 5,462,504

# Pre-Program Operating Instructions With Express Keys 2-20

## BASIC START-UP

- Plug machine into grounded 120 VAC outlet.
- Turn on the power switch
- Step onto the treadmill
- Straddle the treadbelt.
- Insert safety key into console behind the grab bar.

**Caution:** When the safety key is inserted, the treadmill will return to 0% grade. Please keep the area under the treadmill free from obstructions.

- Connect safety lanyard clip to the waistband of your clothing. Do not operate treadmill without safety lanyard clipped to your clothing at about waist height.

Message will read  
**WGT FAST/SLOW** followed by  
**PRESS SELECT**  
**PRESS START**









Last entered weight will be displayed. Use











to change the weight and press



## PROGRAM MODE

- **NEXT UP/DN** message appears, followed by **EDIT SELECT**. Press  to access the programs
- Press  to scroll to desired workout. Select a level using  
- Press 
- After program and level have been selected, set time using   keys (15:00-99:00 minutes)
- Press  to begin
- **Carefully** step onto treadbelt.

- **To Stop your workout:** slow machine to below 2 mph by pressing . Press .
- **To reset distance, time, and calories:** (During workout) Press and hold  until zeros appear in the time, distance, calorie windows. If not in use, press and hold .
- **To change level during workout:** press and hold . Press   keys to select new level. After new level is entered press .
- **Recall of accumulated data:** after workout is complete data may be recalled by pressing the .

## ACCESS YOUR FAVORITE WORKOUT WITH EXPRESS KEYS ON HRC MODELS.

### EXPRESS COMMAND

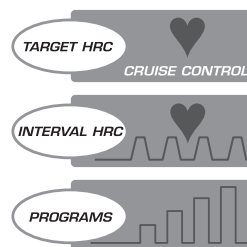

HRC models feature Express Keys allowing simple access to HRC workouts or pre-programs.

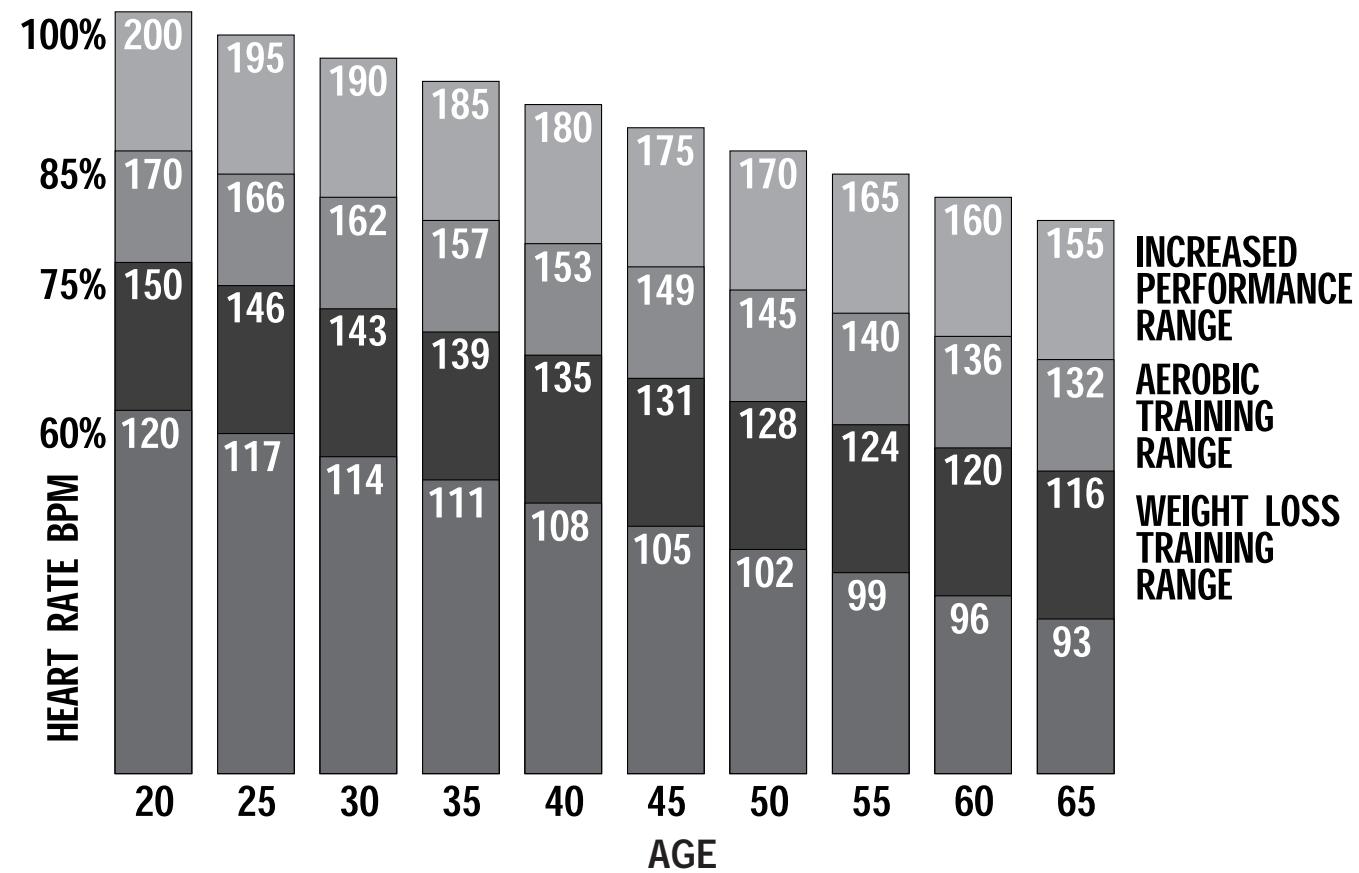

**WARNING!**

Consult your physician to determine your target heart rate before using the heart rate control mode of this treadmill!

The above chart is to be used only as an average reference point and is in NO WAY a recommendation of your personal abilities!

Medications may affect your heart rate.  
Consult your physician for specific advice before exercising.

Do not use this treadmill if you have an acute illness, cold or fever.

**STOP EXERCISING IF:**

- YOU FEEL FAINT OR DIZZY.
- YOU EXCEED YOUR MAXIMUM HEART RATE SET BY YOUR PHYSICIAN.

**THE F.I.T. FORMULA**

(Frequency, Intensity, Time)

**YOUR FITNESS PROGRAM**

You can get valuable fitness benefits from your TRUE Treadmill. Using the treadmill regularly may increase the ability of your heart and lungs to supply oxygen and nutrients to exercising muscles over an extended period of time. The treadmill will also help you develop added muscle endurance and balanced strength throughout your body.

**DETERMINING YOUR NEEDS**

Calculate your maximum heart rate as a first step in developing your fitness program. The formula to calculate average maximum heart rate for one minute is 220 beats per minute minus your age. To find your pulse, locate a vein on your neck or inside your wrist, then count beats for ten seconds, then multiply by six. (Refer to chart on page 2-20.)

It's also important to know your target training zone or target heart rate. The American Heart Association (AHA) defines target heart rate as 60-75% of your maximum heart rate. This is high enough to condition, but well within safe limits. The AHA recommends that you aim for the lower part of the target zone (60%) during the first few months of your exercise program. As you gradually progress you can increase your target to 75%. According to the AHA, "Exercise above 75% of the maximum heart rate may be too strenuous unless you are in excellent physical condition. Exercise below 60% gives your heart and lungs little conditioning."

In addition to monitoring your heart rate as you exercise, be certain of how quickly your heart rate recovers. If your heart rate is over 120 beats per minute five minutes after exercising, or is higher than normal the morning after exercising, your exertion may be too strenuous for your current level of fitness. Reducing the intensity of your workout

is recommended.

The age-adjusted target heart rates indicated in the previous chart reflect averages. A variety of factors (including medication, emotional state, temperature, and other conditions) can affect the exercise heart rate appropriate for you.

**WARNING: Consult your doctor to establish the exercise intensity (target heart rate zone) appropriate for your age and condition before beginning any exercise program.**

**BEGINNING YOUR EXERCISE PROGRAM**

**WARM-UP: Slow and Deliberate Exercise**  
You are not warmed up until you begin to perspire lightly and breath more deeply. Warming up prepares your heart and other muscles for more intense exercise and helps you avoid premature exhaustion. Begin each workout by walking even if you plan to run. Start slowly, exploring different speeds until you can comfortably sustain your speed, a suggested minimum of three minutes. Perspiration on your brow is a good indicator of a thorough warm-up. The older you are, the longer your warm-up period should be.

**WORKOUT: Brisk and Rhythmic Exercise**  
The workout trains and conditions your heart, lungs, and muscles to operate more efficiently. Increase exercise in response to your heart rate to train and strengthen your cardiovascular system. Concentrate on moving your arms and legs smoothly. Walk naturally and avoid jerking motions that can cause pulled muscles, sprained joints, and loss of balance.

**COOL DOWN: Slow and Relaxed Exercise**  
Cooling down relaxes your muscles and gradually lowers your heart rate. Slowly reduce your workload until your heart rate is below 60% of your maximum heart rate. The cool down should last at least five minutes, followed by some light stretching to enhance your flexibility.

# UNDERSTANDING THE F.I.T. FORMULA

The workout portion of your exercise program consists of three major variables: Frequency, Intensity, and Time.

## FREQUENCY: How Often You Exercise

You should exercise three to five times a week to improve your cardiovascular and muscle fitness. Improvements are minimal with less frequent exercise.

## INTENSITY: How Hard You Exercise

Intensity of exercise is reflected in your heart rate. Exercise must be sufficiently rigorous to strengthen your heart muscle and condition your cardiovascular system. Only your doctor can prescribe the target training heart range appropriate for your particular needs and physical condition.

- Start with exercise that stimulates you to breathe more deeply.
- Alternate periods of moderate and easy exercise to help your body adapt to new levels of exertion without unnecessary strain.
- If you are just beginning an exercise program, you may be most comfortable walking at a speed of 1-2 MPH. As you use your treadmill regularly, higher speeds may be more comfortable and more effective.
- Inability to maintain a smooth, rhythmic motion suggests that your speed and/or elevation may be too great.
- If you feel out of breath before you have exercised 12 minutes, you are probably overdoing it.

As your fitness level improves, you will need to increase your workload in order to reach your target heart rate. The first increase may be necessary after two to four weeks of regular exercise. Never exceed your target heart rate zone.

Increase the speed and/or incline on the treadmill to raise your heart rate to the level recommended by your doctor. The incline feature can be used to greatly increase the workload without increasing speed. The chart below indicates how much the effort changes with each percent of grade at popular speeds for a person weighing 155 pounds.

## METS

One MET is the amount of energy your body uses when you're resting. If a physical activity has an equivalent of 6 METS, its energy demands are 6 times that of your resting state. The MET is a useful measurement, because it accounts for differences in body weight.

MPH	2.0	2.5	3.0	3.5	4.0
Minutes per mile	30	24	20	17	15
Grade %	METS	METS	METS	METS	METS
0	2.5	2.9	3.3	3.7	4.1
1	2.8	3.3	3.7	4.2	4.6
2	3.1	3.6	4.1	4.7	5.2
3	3.4	3.9	4.5	5.1	5.7
4	3.7	4.3	5.0	5.6	6.3
5	3.9	4.7	5.4	6.1	6.8
6	4.2	5.0	5.8	6.6	7.4
7	4.5	5.3	6.2	7.1	7.9
8	4.7	5.7	6.6	7.6	8.5
9	5.0	6.0	7.1	8.0	9.0
10	5.3	6.4	7.5	8.5	9.6
11	5.6	6.7	7.9	9.0	10.1
12	5.9	7.1	8.3	9.5	10.7
13	6.1	7.4	8.7	10.0	11.2
14	6.4	7.7	9.1	10.5	11.8
15	6.7	8.1	9.5	10.9	12.3
16	7.0	8.4	10.0	11.4	12.9

## TIME: How Long You Exercise

Sustained exercise conditions your heart, lungs, and muscles. The longer you are able to sustain exercise within your target heart range, the greater the aerobic benefits.

- To begin, maintain two to three minutes of steady, rhythmic exercise, then check your heart rate.
- The initial goal for aerobic training is 12 continuous minutes.
- Increase your workout time approximately one or two minutes per week until you are able to maintain 20-30 continuous minutes at your training heart rate.

## USING THE F.I.T. FORMULA

The F.I.T. formula and chart are designed to help you begin a program tailored to your needs. You may wish to keep an exercise log to monitor your progress.

## BEGINNING FITNESS PROGRAM

If you cannot sustain 12 continuous minutes in your target heart rate zone, exercise several times a day to get into the habit of exercise.

Try to reach and maintain 60-65% of your maximum heart rate. Alternate exercise with periods of rest until you can sustain 12 continuous minutes of exercise at 60-65% of your maximum heart rate.

Begin exercising in three to five minute sessions.

## ESTABLISHING AEROBIC FITNESS

If you can sustain 12 but not 20 continuous minutes of exercise in your target heart rate zone:

- Exercise three to five days a week. Rest at least two days per week.
- Try to reach and maintain 60-75% of your maximum heart rate with moderate rhythmic exercise.
- Begin with 12 continuous minutes. Increase your time by one to two minutes per week until you can sustain 20 continuous minutes.

## MAINTAINING AEROBIC FITNESS

If you can sustain 20 continuous minutes in your target heart rate zone, begin to increase the length and intensity of your workout:

- Exercise four to six days a week or on alternate days.
- Try to reach and maintain 70-85% of your maximum heart rate with moderate to somewhat hard exercise.
- Exercise for 20-30 minutes.

## MANAGING WEIGHT

Consistent aerobic exercise will help you change your body composition by lowering your percentage of body fat. If weight loss is a goal, combine an increase in the length of your workouts with a moderate decrease in caloric intake. For weight control, how long and how often you exercise is more important than how hard you exercise.

- Exercise four to five times a week.
- Try to reach and maintain 60-75% of your maximum heart rate with moderate exercise.
- Exercise for 30-45 minutes at 60-65% percent of your target heart rate.

Here are some tips to achieving your weight management goal:

- Consume most of your dietary calories at breakfast and lunch, and eat a light dinner. Do not eat close to bedtime.
- Exercise before meals. Moderate exercise will help suppress your appetite.
- Take exercise breaks throughout the day to help increase metabolism (calorie expenditure).

## ATHLETIC TRAINING

When you are training to improve strength and performance:

- Exercise four to five days a week.
- Alternate exercise days and intervals of hard to very hard exercise with easy to moderate exercise.
- Exercise for 30 minutes or longer.

## THE F.I.T. CHART

	FREQUENCY	INTENSITY	TIME
BEGINNING EXERCISE PROGRAM	2-3 times/week	60-65% of MHR*	3-5 minutes
ESTABLISHING AEROBIC FITNESS	3-4 days/week	60-75% of MHR*	12-20 minutes
MAINTAINING AEROBIC FITNESS	4-6 days/week	70-85% of MHR*	20-30 minutes

\*MHR = maximum heart rate

**WARNING:** These strategies are intended for average healthy adults. If you have pain or tightness in your chest, an irregular heartbeat, shortness of breath or if you feel faint or have any discomfort when you exercise - STOP! Consult your physician before continuing. Remember, every workout should begin with a warm-up and finish with a cool-down.

**MAINTENANCE SCHEDULE**

LUBRICATION	3-2
DAILY CARE	3-3,4
WEEKLY CARE	3-5,6,7
MONTHLY CARE	3-8,9
QUARTERLY CARE	3-10,11

**EXPLODED DIAGRAMS**

WIRING DIAGRAMS	3-12,13
EXPLODED DIAGRAMS-700	3-14,15,16
PARTS LIST-600/700/725/750	3-17

**TROUBLESHOOTING FLOWCHARTS**

DIAGNOSTICS/ERROR MESSAGES	3-18
NO DISPLAY	3-19
NO BELT MOVEMENT	3-20
CIRCUIT BREAKER TRIPS AT START UP	3-21
TREADBELT STOPS DURING WORKOUT	3-22
SPEED FLUCTUATION	3-23
INCLINE MALFUNCTION	3-24
E3:EEPROM ERROR	3-25
HEART RATE NOT FUNCTIONING	3-26

**TEST PROCEDURES**

CALIBRATION	3-27
GROUNDING OUTLET	3-27
AMP DRAW	3-27,28
SPEED SENSOR	3-29
VOLTAGE TO DRIVE MOTOR	3-29
DRIVE MOTOR	3-30
DRIVE BELT TENSION	3-30
TREADBELT TENSION	3-31
INCLINE POTENTIOMETER	3-31
VOLTAGE TO INCLINE MOTOR	3-32

**LUBRICATION**

True Commercial Series Treadmills are self lubricating and do not require you to apply wax to the deck or belt.

It is important to inspect the Autowaxer lubrication system at least once every 6 months to ensure that it is not worn through the wax channel and damaging the treadbelt.

Lay the unit on the side and visually inspect the Autowaxer mounted to the underside of the deck. At least 1/2 inch should remain on the wax channel. If not, replace the wax channel.

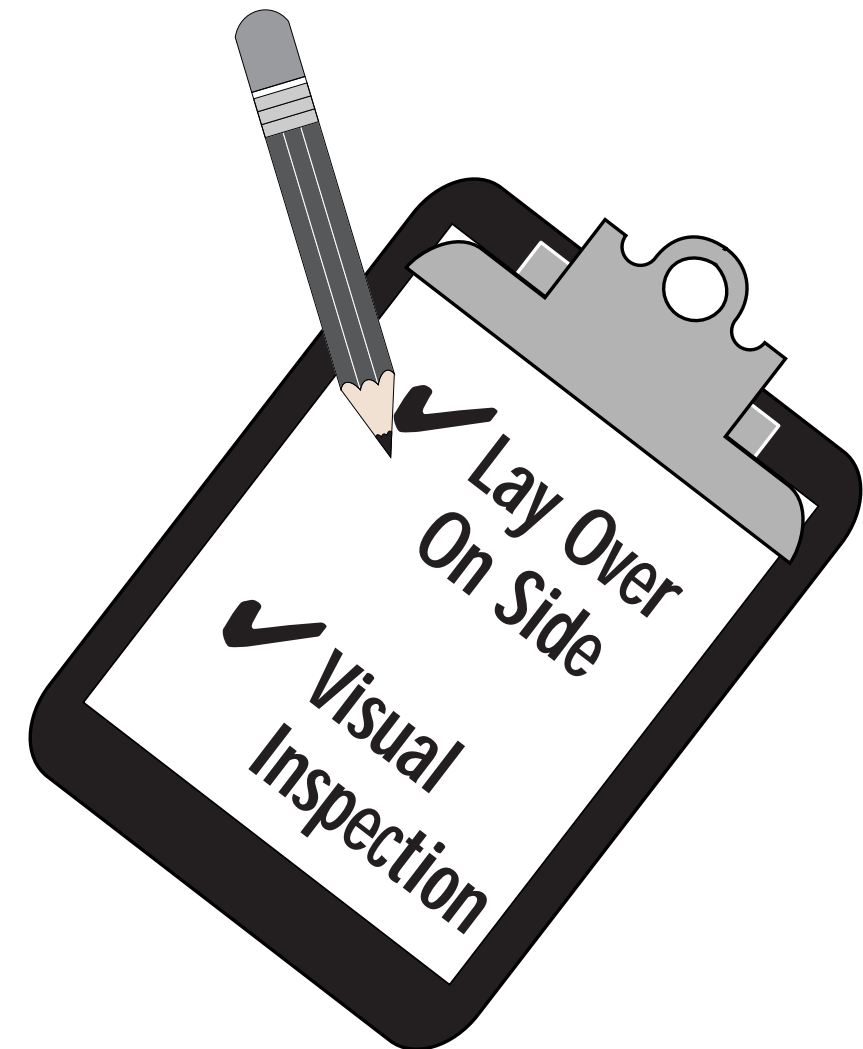

**DAILY CARE AND SERVICE**

True Commercial Series Treadmills should be wiped clean daily to remove excess perspiration. We also recommend that you encourage your employees and clients to wipe excessive perspiration from the units after each use. This can be accomplished with a dry soft towel or cloth.

**NOTE: It is important not to wipe under the belt when cleaning dust or debris off the unit.**

To prevent damage caused by power surges, we also suggest that the unit be unplugged during non-business hours.

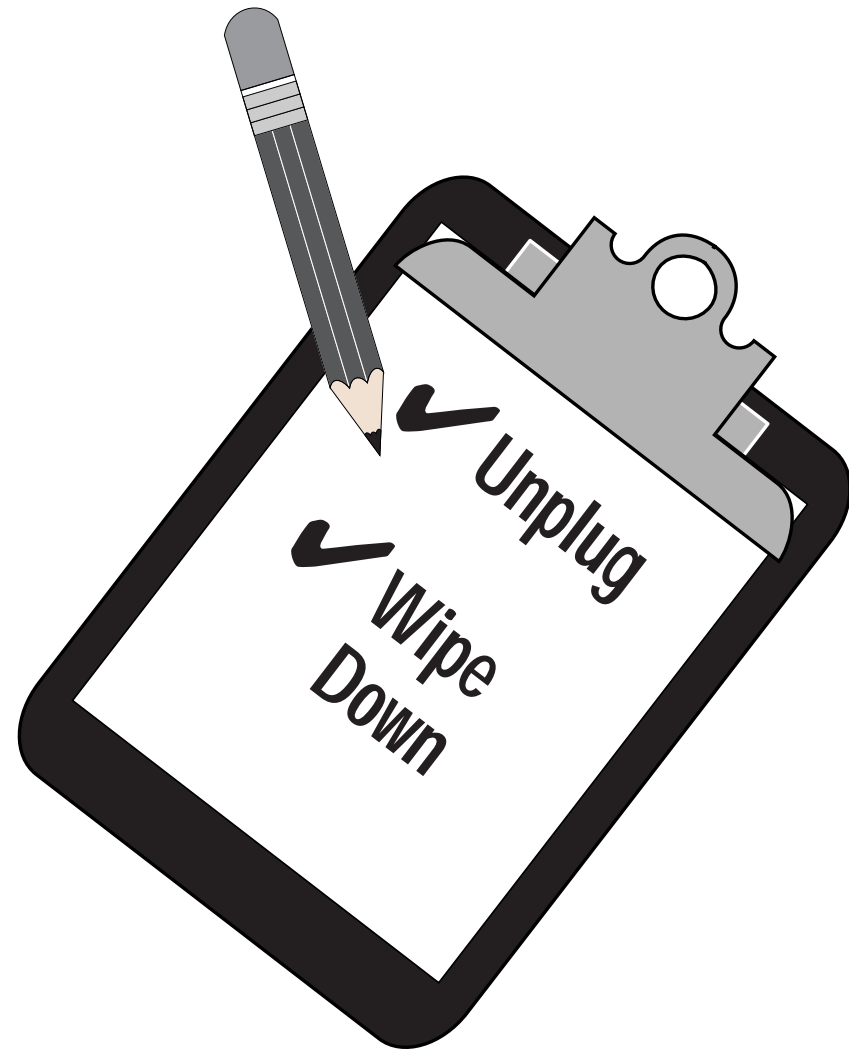

**DAILY CHECK LIST**

Month \_\_\_\_\_ Year \_\_\_\_\_  
Initial As Completed

DATE	UNPLUG	WIPE DOWN WITH DAMP CLOTH
1.	<input type="checkbox"/>	<input type="checkbox"/>
2.	<input type="checkbox"/>	<input type="checkbox"/>
3.	<input type="checkbox"/>	<input type="checkbox"/>
4.	<input type="checkbox"/>	<input type="checkbox"/>
5.	<input type="checkbox"/>	<input type="checkbox"/>
6.	<input type="checkbox"/>	<input type="checkbox"/>
7.	<input type="checkbox"/>	<input type="checkbox"/>
8.	<input type="checkbox"/>	<input type="checkbox"/>
9.	<input type="checkbox"/>	<input type="checkbox"/>
10.	<input type="checkbox"/>	<input type="checkbox"/>
11.	<input type="checkbox"/>	<input type="checkbox"/>
12.	<input type="checkbox"/>	<input type="checkbox"/>
13.	<input type="checkbox"/>	<input type="checkbox"/>
14.	<input type="checkbox"/>	<input type="checkbox"/>
15.	<input type="checkbox"/>	<input type="checkbox"/>
16.	<input type="checkbox"/>	<input type="checkbox"/>
17.	<input type="checkbox"/>	<input type="checkbox"/>
18.	<input type="checkbox"/>	<input type="checkbox"/>
19.	<input type="checkbox"/>	<input type="checkbox"/>
20.	<input type="checkbox"/>	<input type="checkbox"/>
21.	<input type="checkbox"/>	<input type="checkbox"/>
22.	<input type="checkbox"/>	<input type="checkbox"/>
23.	<input type="checkbox"/>	<input type="checkbox"/>
24.	<input type="checkbox"/>	<input type="checkbox"/>
25.	<input type="checkbox"/>	<input type="checkbox"/>
26.	<input type="checkbox"/>	<input type="checkbox"/>
27.	<input type="checkbox"/>	<input type="checkbox"/>
28.	<input type="checkbox"/>	<input type="checkbox"/>
29.	<input type="checkbox"/>	<input type="checkbox"/>
30.	<input type="checkbox"/>	<input type="checkbox"/>
31.	<input type="checkbox"/>	<input type="checkbox"/>

PHOTOCOPY AND RETAIN THIS ORIGINAL CHART FOR REPEATED USE.

**WEEKLY CARE AND SERVICE**

True Commercial Series Treadmills should be wiped down once a week with a water dampened, soft cloth when unplugged. Be careful not to spill liquid or get excessive moisture between the edge of the digital display panel and the console, as this may create an electrical hazard or cause premature failure of the electronics.

**Important: Do not clean or wipe the top of the deck under the running belt.**

We also suggest a visual inspection of the control panel, power cord, treadbelt, and circuit breaker be completed at this time.

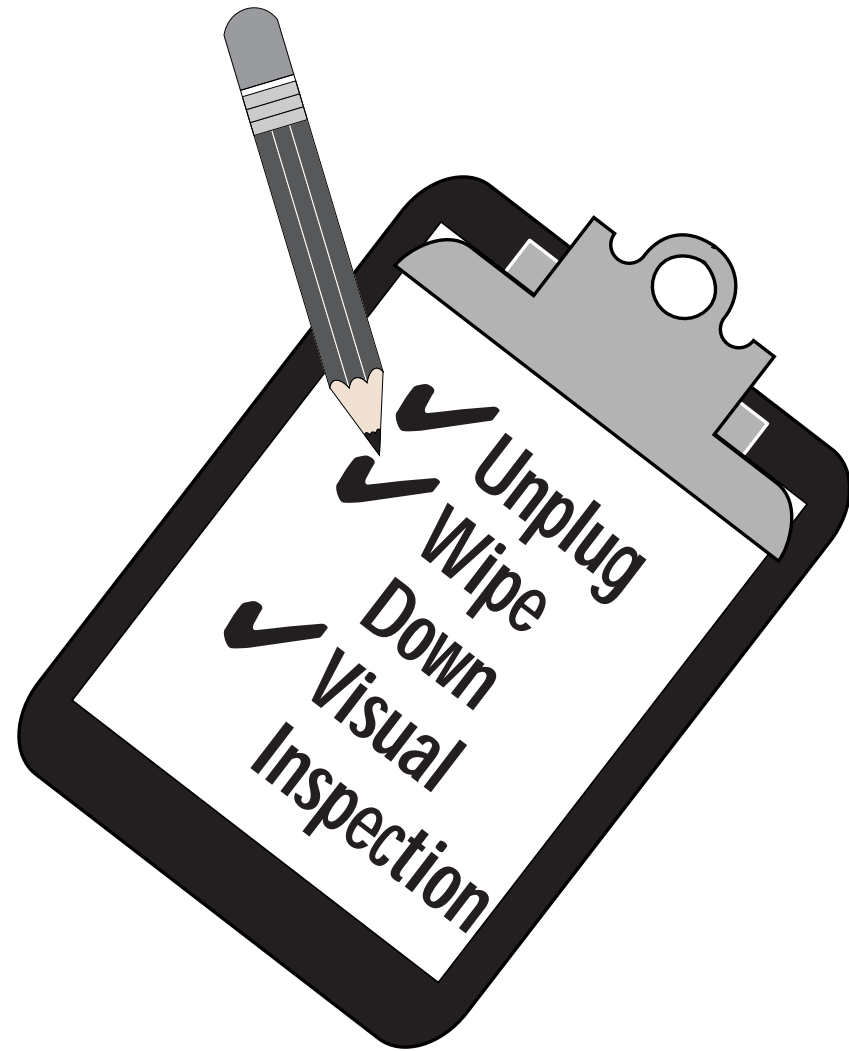

**WEEKLY CHECK-LIST**

Initial As Completed

WEEK #	DATE	WIPE DOWN	VISUAL INSPECTION
1.	_____	<input type="checkbox"/>	<input type="checkbox"/>
2.	_____	<input type="checkbox"/>	<input type="checkbox"/>
3.	_____	<input type="checkbox"/>	<input type="checkbox"/>
4.	_____	<input type="checkbox"/>	<input type="checkbox"/>
5.	_____	<input type="checkbox"/>	<input type="checkbox"/>
6.	_____	<input type="checkbox"/>	<input type="checkbox"/>
7.	_____	<input type="checkbox"/>	<input type="checkbox"/>
8.	_____	<input type="checkbox"/>	<input type="checkbox"/>
9.	_____	<input type="checkbox"/>	<input type="checkbox"/>
10.	_____	<input type="checkbox"/>	<input type="checkbox"/>
11.	_____	<input type="checkbox"/>	<input type="checkbox"/>
12.	_____	<input type="checkbox"/>	<input type="checkbox"/>
13.	_____	<input type="checkbox"/>	<input type="checkbox"/>
14.	_____	<input type="checkbox"/>	<input type="checkbox"/>
15.	_____	<input type="checkbox"/>	<input type="checkbox"/>
16.	_____	<input type="checkbox"/>	<input type="checkbox"/>
17.	_____	<input type="checkbox"/>	<input type="checkbox"/>
18.	_____	<input type="checkbox"/>	<input type="checkbox"/>
19.	_____	<input type="checkbox"/>	<input type="checkbox"/>
20.	_____	<input type="checkbox"/>	<input type="checkbox"/>
21.	_____	<input type="checkbox"/>	<input type="checkbox"/>
22.	_____	<input type="checkbox"/>	<input type="checkbox"/>
23.	_____	<input type="checkbox"/>	<input type="checkbox"/>
24.	_____	<input type="checkbox"/>	<input type="checkbox"/>
25.	_____	<input type="checkbox"/>	<input type="checkbox"/>
26.	_____	<input type="checkbox"/>	<input type="checkbox"/>

PHOTOCOPY AND RETAIN THIS ORIGINAL CHART FOR REPEATED USE.

**WEEKLY CHECK-LIST**

Initial As Completed

WEEK #	DATE	WIPE DOWN	VISUAL INSPECTION
27.	_____	<input type="checkbox"/>	<input type="checkbox"/>
28.	_____	<input type="checkbox"/>	<input type="checkbox"/>
29.	_____	<input type="checkbox"/>	<input type="checkbox"/>
30.	_____	<input type="checkbox"/>	<input type="checkbox"/>
31.	_____	<input type="checkbox"/>	<input type="checkbox"/>
32.	_____	<input type="checkbox"/>	<input type="checkbox"/>
33.	_____	<input type="checkbox"/>	<input type="checkbox"/>
34.	_____	<input type="checkbox"/>	<input type="checkbox"/>
35.	_____	<input type="checkbox"/>	<input type="checkbox"/>
36.	_____	<input type="checkbox"/>	<input type="checkbox"/>
37.	_____	<input type="checkbox"/>	<input type="checkbox"/>
38.	_____	<input type="checkbox"/>	<input type="checkbox"/>
39.	_____	<input type="checkbox"/>	<input type="checkbox"/>
40.	_____	<input type="checkbox"/>	<input type="checkbox"/>
41.	_____	<input type="checkbox"/>	<input type="checkbox"/>
42.	_____	<input type="checkbox"/>	<input type="checkbox"/>
43.	_____	<input type="checkbox"/>	<input type="checkbox"/>
44.	_____	<input type="checkbox"/>	<input type="checkbox"/>
45.	_____	<input type="checkbox"/>	<input type="checkbox"/>
46.	_____	<input type="checkbox"/>	<input type="checkbox"/>
47.	_____	<input type="checkbox"/>	<input type="checkbox"/>
48.	_____	<input type="checkbox"/>	<input type="checkbox"/>
49.	_____	<input type="checkbox"/>	<input type="checkbox"/>
50.	_____	<input type="checkbox"/>	<input type="checkbox"/>
51.	_____	<input type="checkbox"/>	<input type="checkbox"/>
52.	_____	<input type="checkbox"/>	<input type="checkbox"/>

PHOTOCOPY AND RETAIN THIS ORIGINAL CHART FOR REPEATED USE.

**MONTHLY CARE AND SERVICE**

Once a month the Treadmill should be cleaned of dust and dirt that might accumulate under and behind the Treadmill. Vacuum up small rubber particles from the soles of walking-running shoes which accumulate alongside the belt and behind the machine. **DO NOT CLEAN UNDER THE BELT!**

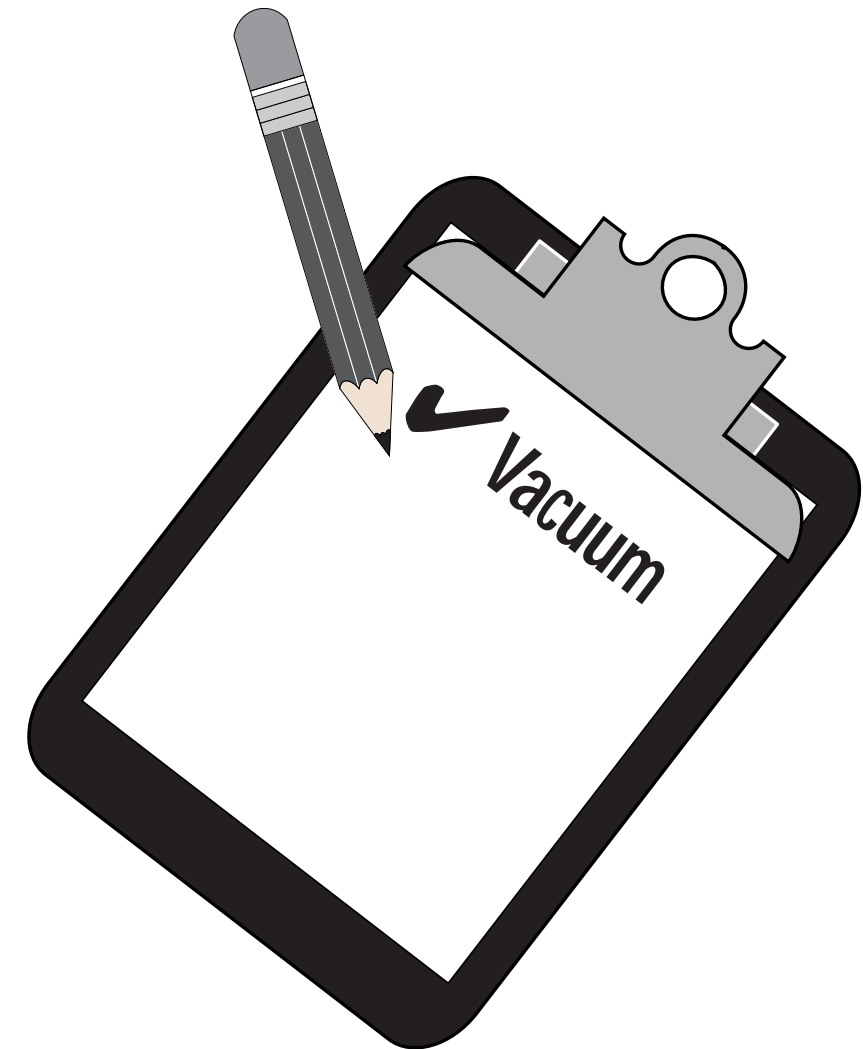

### MONTHLY CHECK-LIST

Initial As Completed

WEEK #	DATE	VACUUM
1.	_____	<input type="checkbox"/>
2.	_____	<input type="checkbox"/>
3.	_____	<input type="checkbox"/>
4.	_____	<input type="checkbox"/>
5.	_____	<input type="checkbox"/>
6.	_____	<input type="checkbox"/>
7.	_____	<input type="checkbox"/>
8.	_____	<input type="checkbox"/>
9.	_____	<input type="checkbox"/>
10.	_____	<input type="checkbox"/>
11.	_____	<input type="checkbox"/>
12.	_____	<input type="checkbox"/>

PHOTOCOPY AND RETAIN THIS ORIGINAL CHART FOR REPEATED USE.

### QUARTERLY CARE AND SERVICE

Once every three (3) months we recommend that the pedestal be removed (See Owner's Manual for Removal Instructions) and the motor area vacuumed thoroughly to remove any dust or particles which may have accumulated. A thorough visual inspection should be performed at this time as well. Be alert for any excessive wear on the drive belt or incline assembly, as well as any other apparent loose electrical connections.

Contact your Authorized True dealer to schedule a service call if needed.

Expert service and maintenance at a modest cost are available through your factory trained authorized True dealer. He maintains a stock of repair parts and has the technical know-how to meet your service needs.

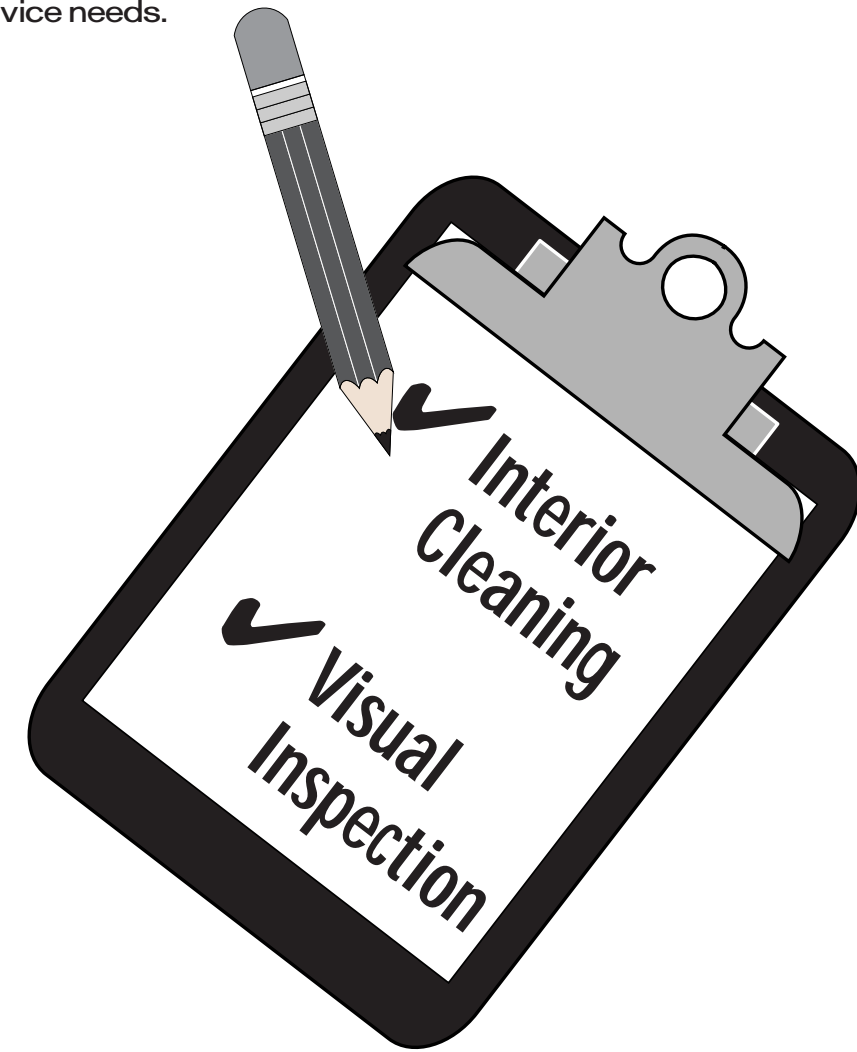

**QUARTERLY CHECK-LIST**

Initial As Completed

QUARTER	DATE	INTERIOR CLEANING/ VISUAL INSPECTION
1.	_____	<input type="checkbox"/>
2.	_____	<input type="checkbox"/>
3.	_____	<input type="checkbox"/>
4.	_____	<input type="checkbox"/>

PHOTOCOPY AND RETAIN THIS ORIGINAL CHART FOR REPEATED USE.

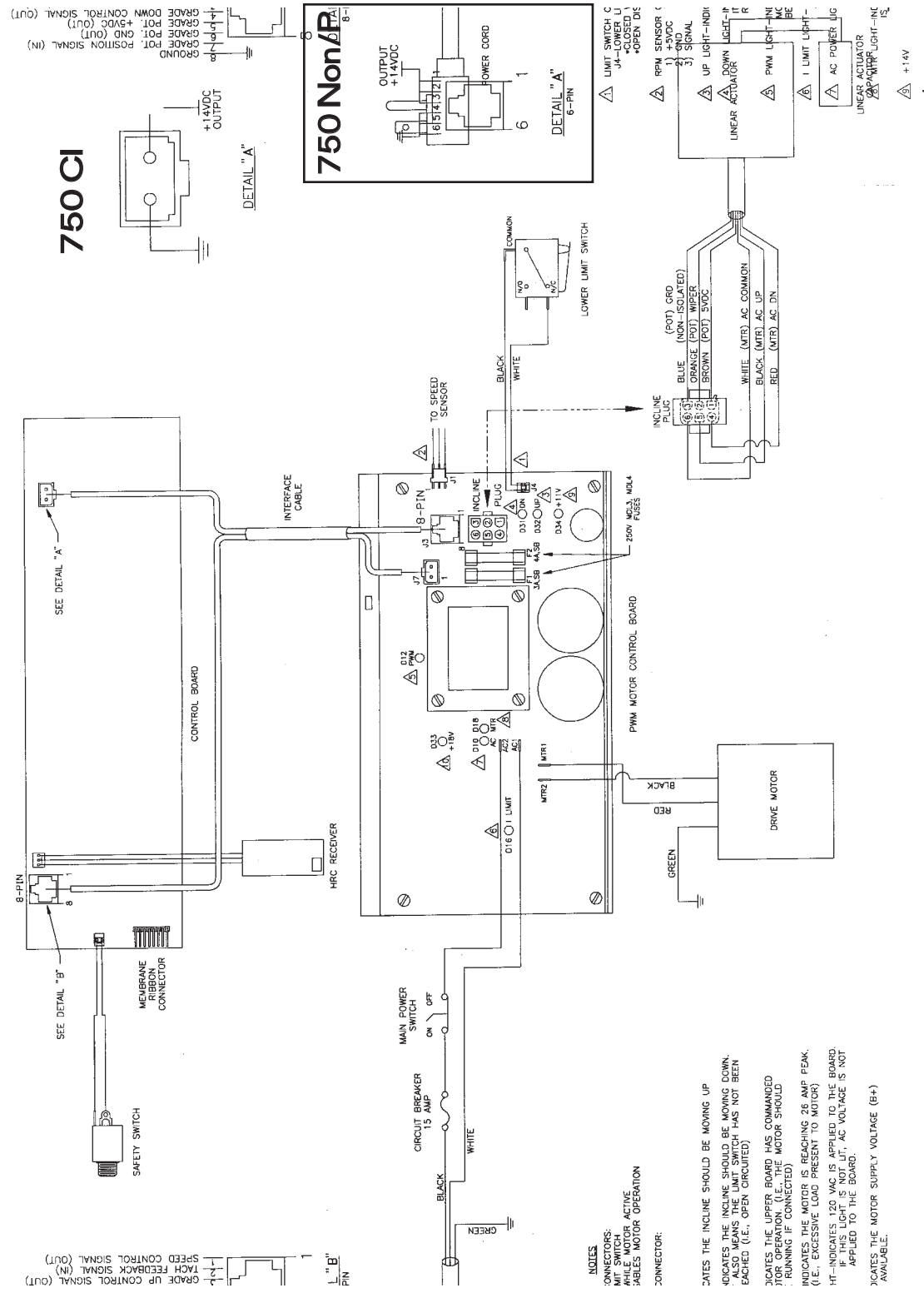



Pedestal

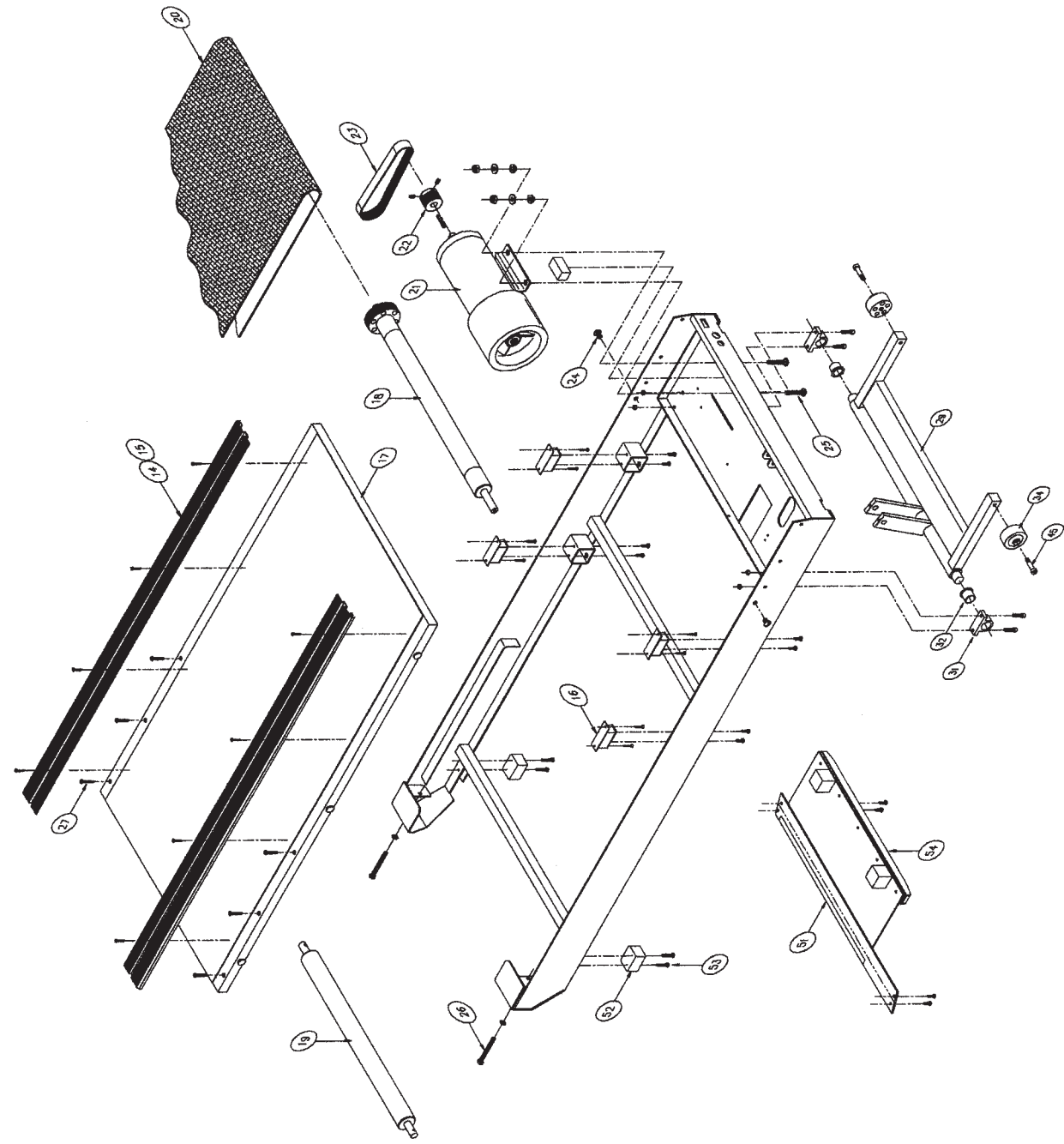

Motor Area

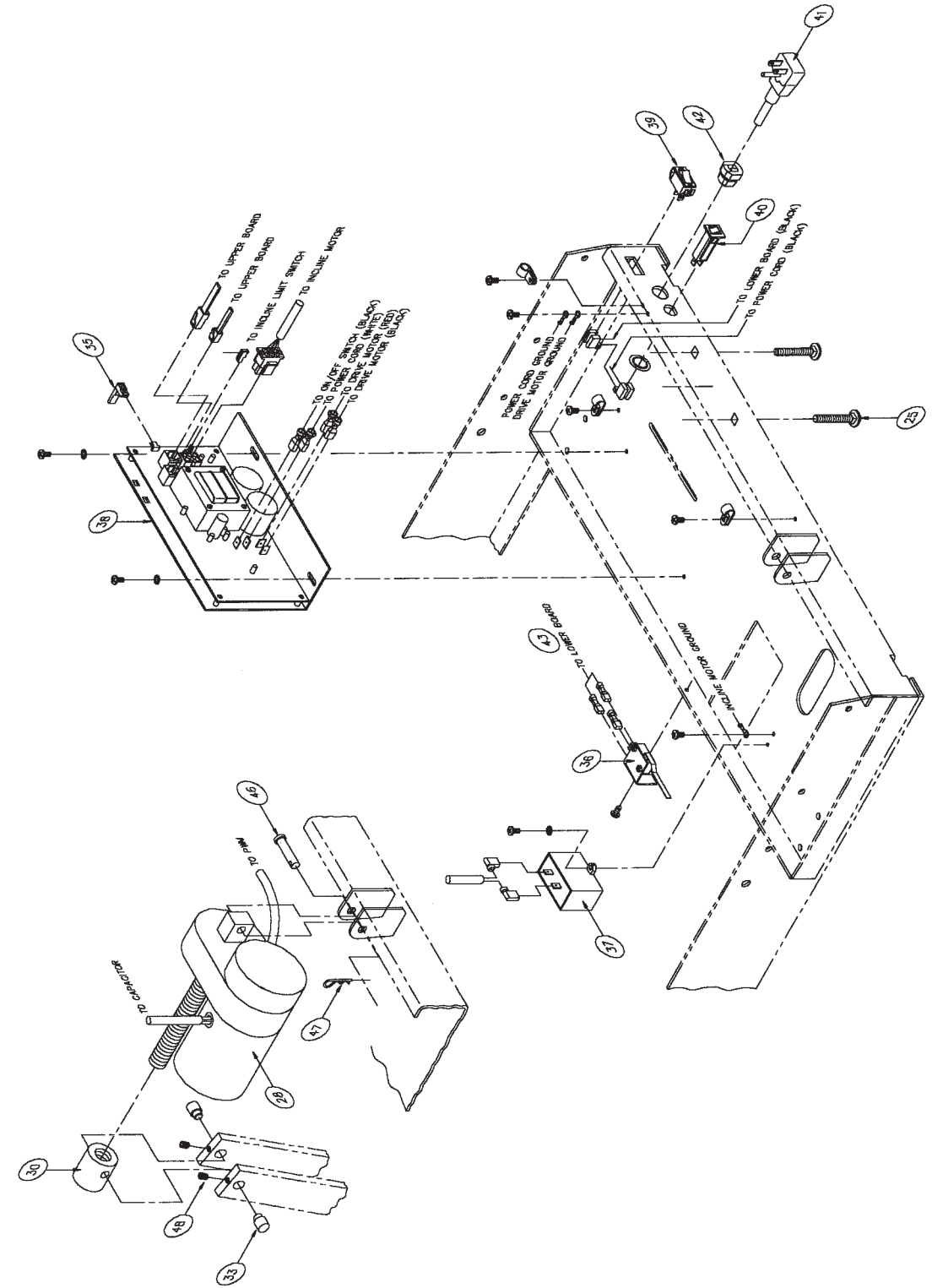

Bubble No.	600 Part No.	700 Part No.	725 Part No.	750 Part No.	Description	Qty
1	70264600	70233500	70233500	70233702	Pedestal Assembly	1
2	70164600	70164600	70164600	70219500	Pedestal Wire Harness	1
2		70162500	70162500	70175000	HRC Pedestal Wire Harness	1
3	70165502	70163500	70163500	70165100	Handlebar Assy	1
4	70265000	70242300	70242300	70242500	Control Panel, Non	1
4	70265002	70242301	70242301	70242501	Control Panel, P	1
4		70242302	70242302	70242600	Control Panel, HRC	1
5	70182800	70182800	70182800	70182800	Safety Switch, Non Removable	1
9	70155900	70207800	70207800	70207800	Pedestal Screws	6
9	70157000	70190000	70190000	70190000	Star Washer	6
12	70178901	70246503	70246503	70246503	Reading Rack, Non	1
12	70246501	70246504	70246504	70246504	Reading Rack, P	1
12		70246505	70246505		Reading Rack, HRC	1
12		70104000	70104000	70104000	Reading Rack Screws	3
13	70104000	70210600	70210600	70210600	Handlebar Screws	4
14	70162101	70162105	70162104	70171800	Straddle Cover, RT	1
15	70162101	70162105	70162104	70171800	Straddle Cover, LT	1
16	70232700	70183400	70183400	70183400	Bumper-Flex Deck	4,6
16	70086700	70086700	70086700	70086700	Bumper Screws	12
17	70157900	70158000	70159100	70169400	Deck	1
18	70255400	70164700	70164700	70168000	Front Roller	1
19	70157400	70186000	70186000	70168300	Rear Roller	1
20	70159400	70214300	70214400	70214500	Treadbelt	1
21	70155101	70119600	70119600	70172000	Drive Motor	1
22	70043100	70155300	70155300	70146500	Drive Motor Pulley	1
23	70006300	70127600	70127600	70127600	Drive Belt	1
24		70208700	70208700	70208700	Front Roller Screw	2
25	70125600	70125600	70125600	70158900	Carriage Bolt	2
26	70158900	70188600	70188600	70170800	Rear Roller Bolt	2
27	70020200	70020200	70020200	70020200	Deck Screws	6
28	70113200	70171500	70171500	70171500	Incline Actuator	1
29	70121100	70121100	70121100	70173800	Incline Riser Assy	1
31	70154600	70154600	70154600	70154600	Incline Bearing Block	2
32	70126200	70126200	70126200	70126200	Flanged Incline Bearing	2
33	70118900	70118900	70118900	70118900	Swivel Pin	2
34	70176701	70176701	70176701	70173900	Front Wheel	2
35	70243200	70243201	70243201	70243201	Speed Sensor	1
36	70121000	70121000	70121000	70121000	Lower Limit Switch	1
37	70183200	70183200	70183200	70183200	Incline Capacitor	1
38	70219200	70219200	70219200	70183500	PWM Motor Controller	1
39	70251100	70251100	70251100	70251100	On/Off Switch	1
40	70017200	70017200	70017200	70017200	Circuit Breaker	1
41	70253100	70214600	70214600	70214600	Power Cord	1
42	70008200	70008200	70008200	70008200	Strain Relief Bushing	1
43	70120500	70120500	70120500	70120500	Wire-PWM to lower limit switch	1
45	70174300	70174300	70174300	70174300	Front Wheel Bolt	2
46	70115500	70115500	70115500	70115500	Clevis Pin	1
47	70116700	70116700	70116700	70116700	Cotter Pin	1
48	70022600	70022600	70022600	70022600	Set Screw, Incline	2
49		70185400	70185400	70185400	HR Receiver	1
50		70138500	70138500	70138500	HR Chest Strap	1
51	70167000	70167000	70167000	70167000	Autowaxer	1
52	70155200	70155200	70155200	70155200	Rear Bumper Feet	2
53	70020200	70020200	70020200	70020200	Bumper Foot Screws	4
54	70239800	70239800	70239800	70239800	Autowaxer Channel	1

**YOUR TRUE TREADMILL IS EQUIPPED WITH BUILT IN DIAGNOSTIC INFORMATION AND MAINTENANCE REMINDERS**

The following error messages will be displayed as they occur. Every time these messages are displayed, a beep will sound twice.

- E1:INCLINE**                      Incline moving when not commanded to.
- E1:MINIMUM**                    Minimum incline calibrating error. Error cleared by calibrating incline.
- E1:RANGE**                        Difference between zero position and maximum incline not sufficient.
- E1:STALL**                        Incline not moving when commanded to.
- E2:OVERSPEED**                  This error occurs when an acceleration >2.1 mph occurs.
- E2:CAL**                            Feedback cannot reduce or increase speed to target. Error cleared by calibrating.
- E3:EEPROM**                        This error occurs when a data error is detected on the EEPROM. Replace the control panel.
- E5:SENSOR**                        This message is displayed when there is no speed feedback.

The following service messages will be displayed as they occur, as well as for the subsequent six safety key insertions. These messages will be displayed until a key is pressed. Every time these messages are displayed, a beep will sound twice.

- S1:LUBE**                            This message is displayed when inspection of deck lubrication system is recommended.
- S2:CLEAN**                         This message is displayed every 500 miles. - Prompt to clean treadmill.
- S3:MOTOR**                         This message is displayed every 2500 hours. - Prompt to check motor brushes.

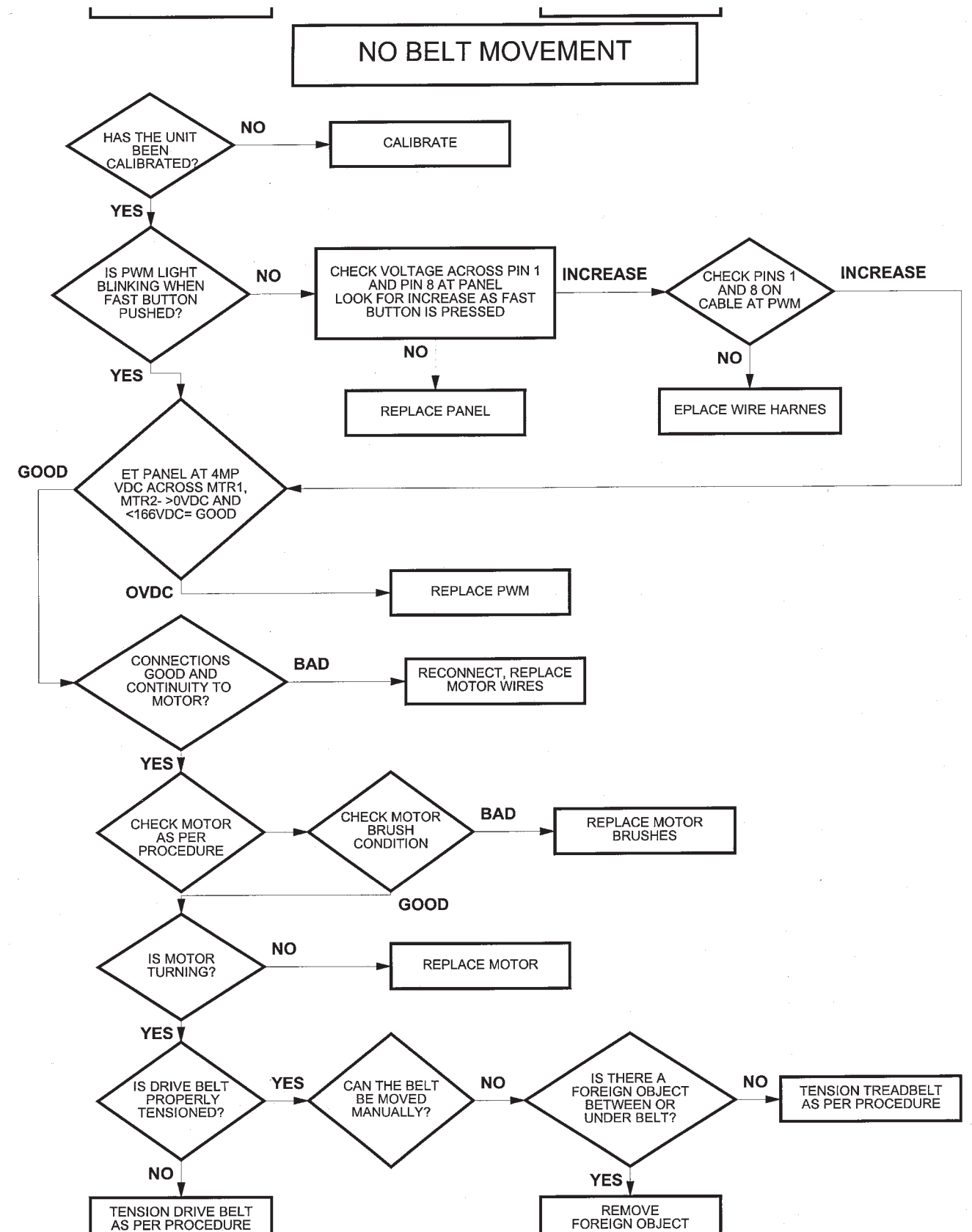
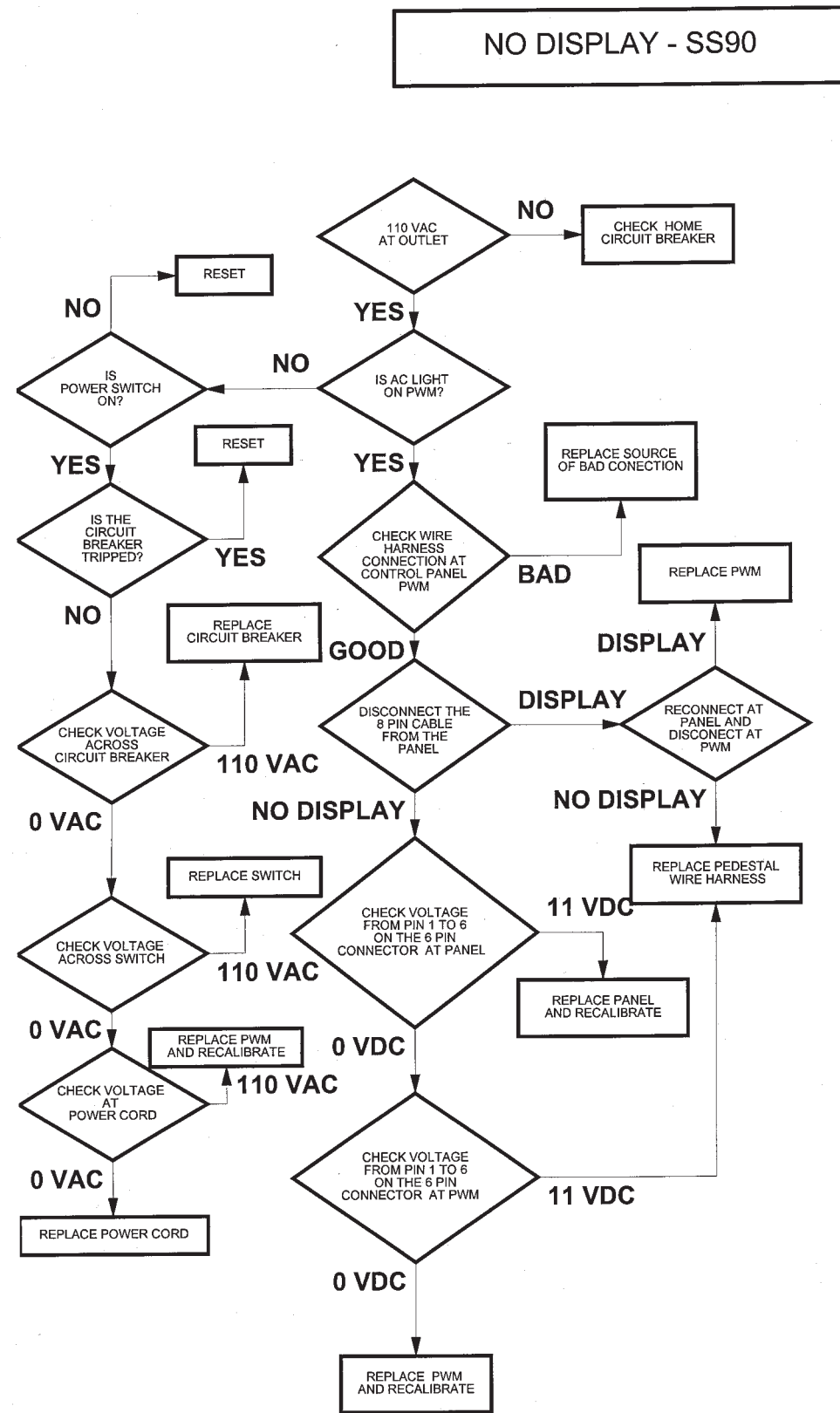

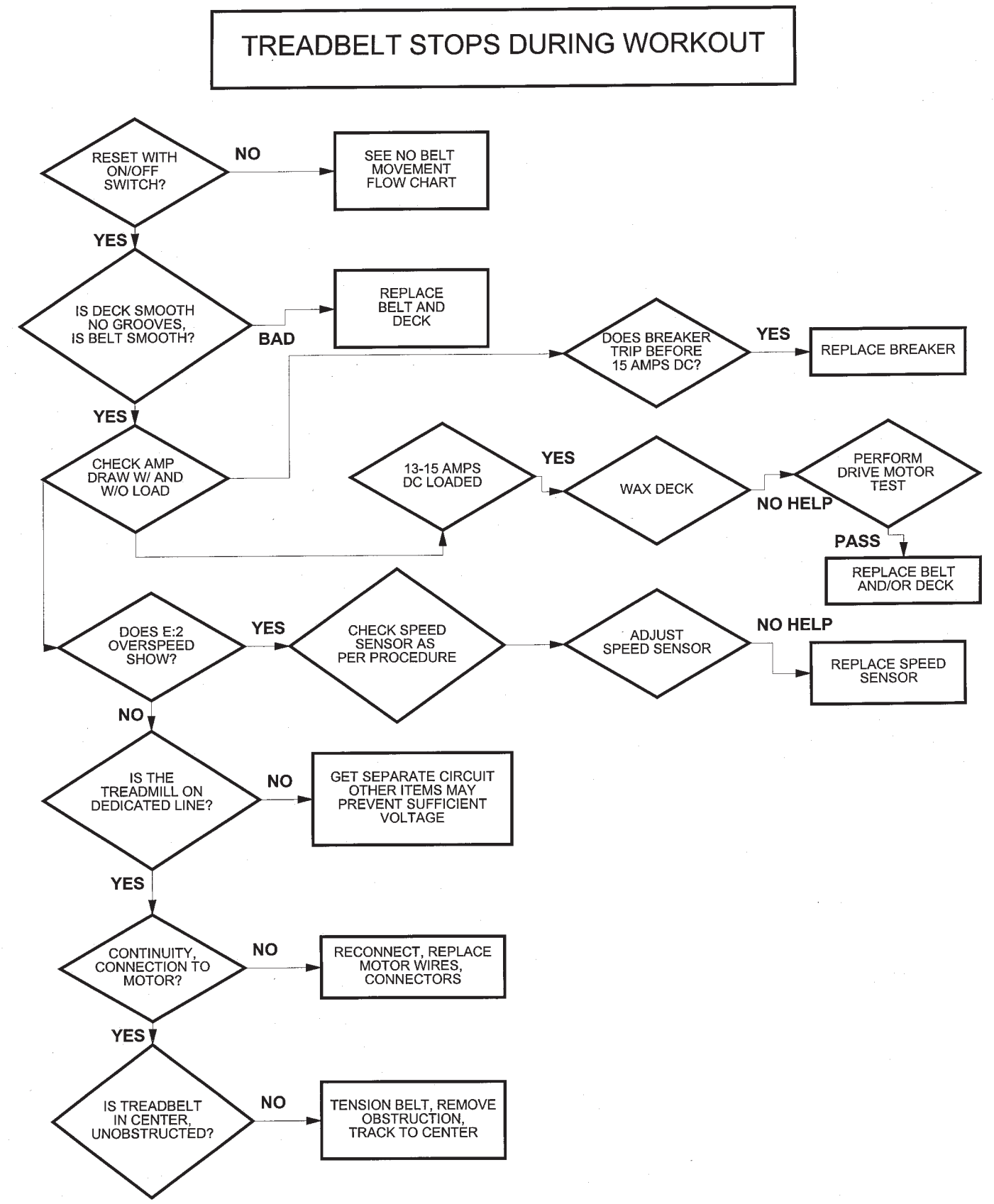
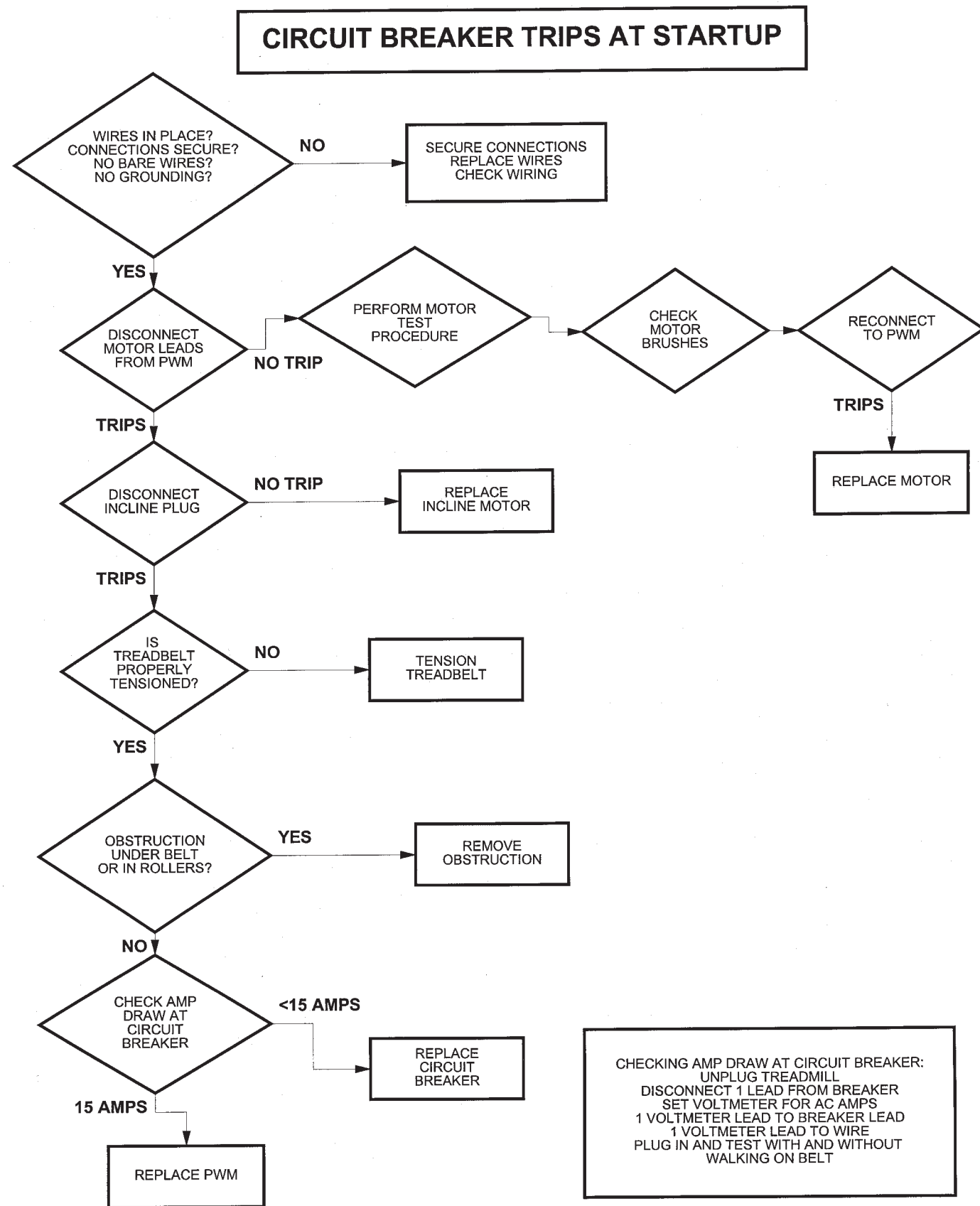

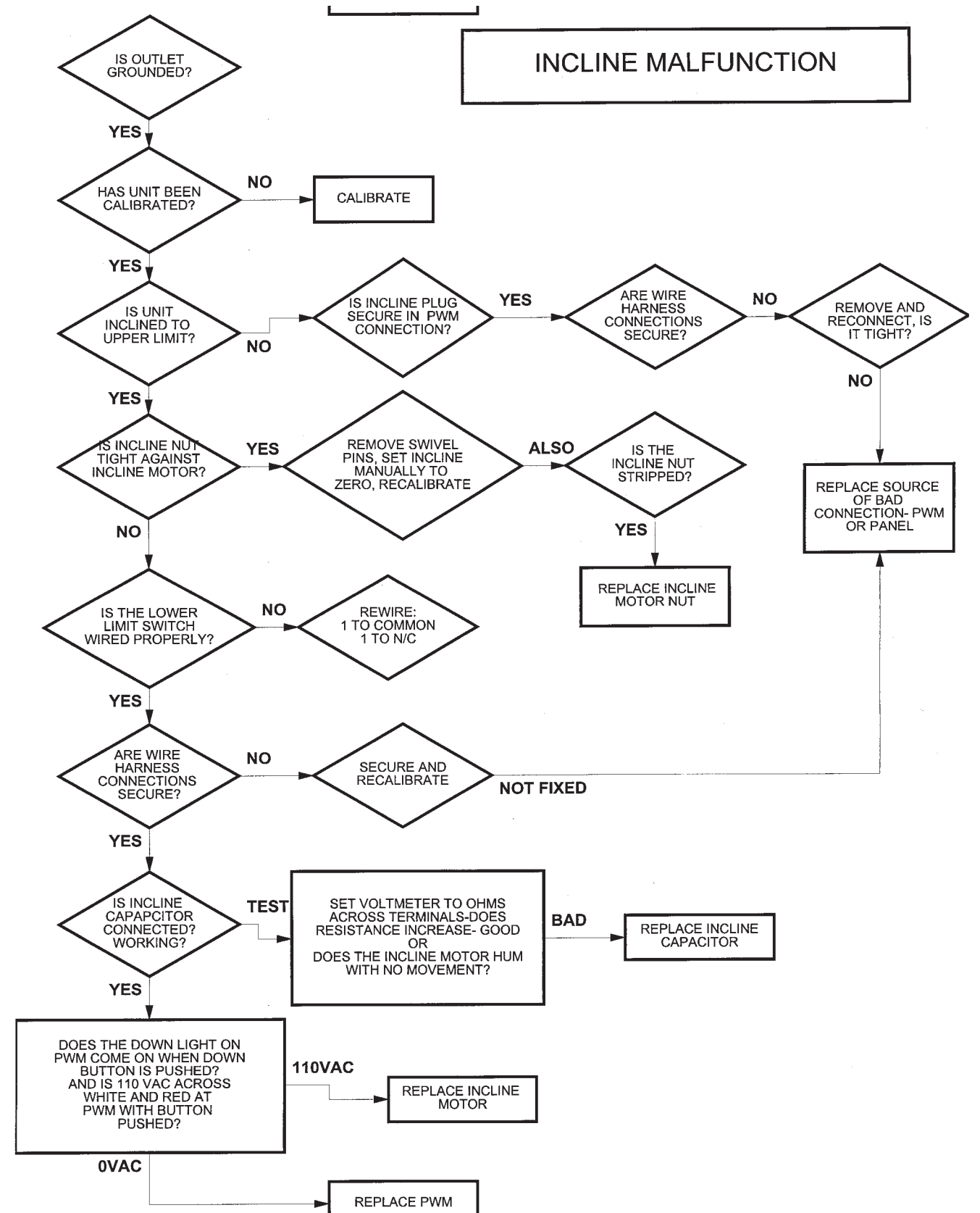
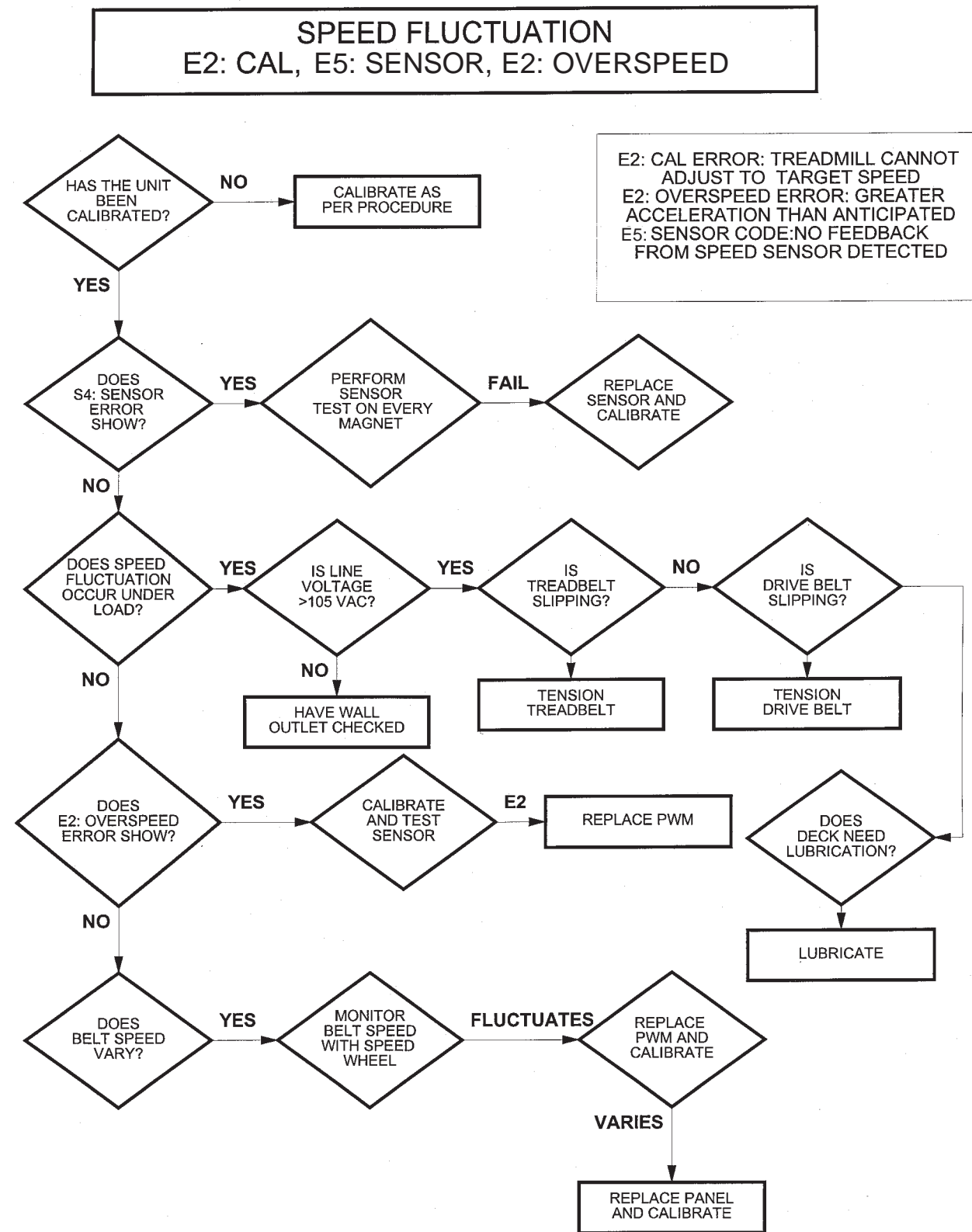

E3: EEPROM ERROR

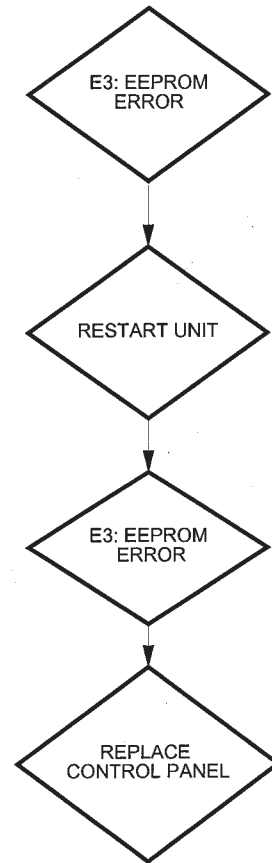

E3: EEPROM ERROR DESIGNATES A SOFTWARE ERROR DURING TREADMILL STARTUP DIAGNOSTICS. CONTROL PANEL REPLACEMENT IS REQUIRED

HEART RATE (HR) NOT FUNCTIONING/  
ERRATIC READINGS

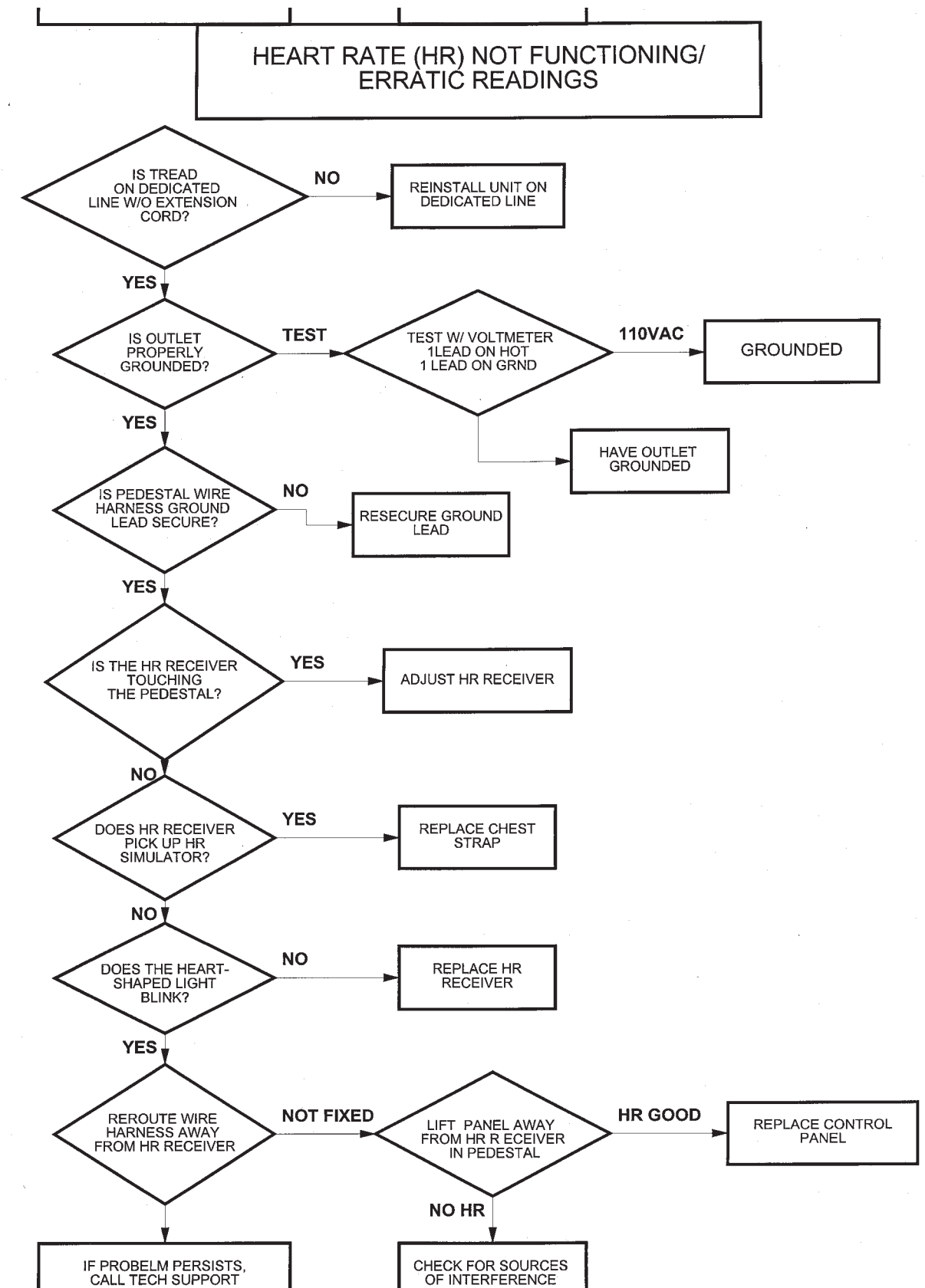

**SPEED INCLINE CALIBRATION TEST (6-8xxxx serial numbers and after)**

Enter Calibration Mode by holding the Up and Down keys while inserting the safety key. The message center window displays: Calibration, Press Start

- NOTE:** In calibration mode, it is possible to check if the speed sensor is reading all the front roller magnets: The Met light will light when a magnet is in front of the sensor. Move the belt slowly with your foot.
- Press Start/Reset to begin calibration
- Treadmill will elevate and speed up/slow down. Wait for belt to stop.
- Message center window will display: Successful, or indicate error area
- Remove and reinsert safety key. Check operation of treadmill

**GROUNDING OUTLET TEST**

- This test is very important for optimal HRC and incline operation.
- Set voltmeter for Volts AC
- Place 1 lead in the right side of the outlet (hot)
- Place 1 lead in the ground plug
- A properly grounded outlet will read 120 VAC

**AMP DRAW TEST**

This test is a good indicator of the wear condition of the belt and deck, and the need for lubrication. The treadmill circuit breaker will trip at 20 amps, so be sure the voltmeter you are using is rated for at least 20 amps when you are load-testing the treadmill. This test can be performed either on one of the AC power cord leads or on one of the DC motor leads from the PWM to the motor. Testing the amp draw at certain speeds without load and with load will signal whether higher than normal amp draw is a result of PWM failure or increased friction from belt and deck wear.

**AC Amp Draw Procedure**

This procedure requires an AC clamp-on ammeter. Place the clamp around either of the power cord leads, black or white. Load test requires a person to walk on the treadbelt for 5- 10 minutes.

2.5 mph without load	2.0 - 2.5 AMPS AC
with load	2.75 - 3.75 AMPS AC
5.0 mph without load	3.5- 4.0 AMPS AC
with load	5.0 - 7.0 AMPS AC

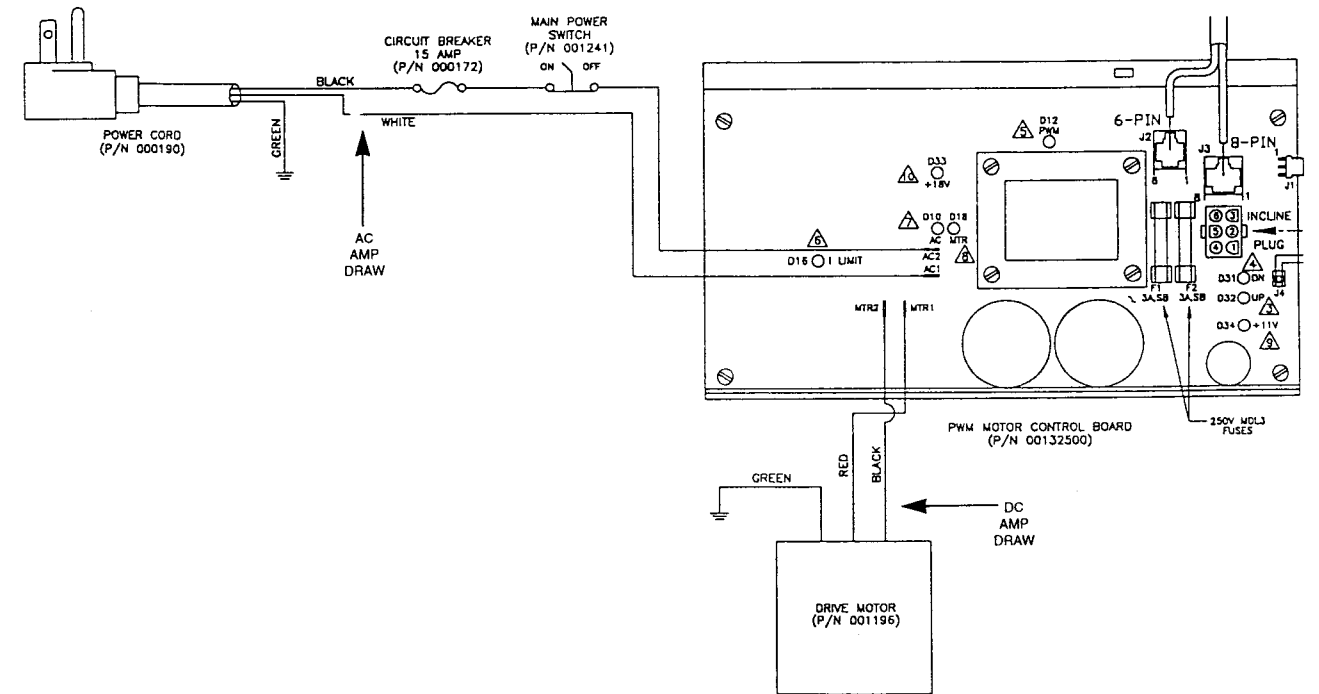

**DC Amp Draw Procedure**

This procedure can be performed with an ordinary voltmeter. (Note: be sure the voltmeter is rated to handle 20 DC amps.) Disconnect the Red motor lead from MTR1 on the PWM. Connect the voltmeter to MTR1 on the PWM and the other voltmeter lead to the Red motor lead so that the voltmeter completes the connection of the PWM to the motor.

2.5 mph without load	4.5 - 5.0 AMPS DC
with load	7.0 - 7.5 AMPS DC
5.0 mph without load	5.0 - 5.5 AMPS DC
with load	8.5 - 9.0 AMPS DC

Higher than normal amp draws without load may signal that belt tension is too tight or there is a problem in the Drive Motor or PWM. Perform the Drive motor Test and visually check the motor brushes before replacing the PWM. Higher than normal amp draws with load after normal readings without load signal belt and deck friction which may require lubrication or replacement.

**SPEED SENSOR TEST**

This test is used to verify sensor operation in conditions of Speed Fluctuation, E2: Cal error, S4: Sensor error, E2: Overspeed error, or Unsuccessful Calibration.

In calibration mode before pressing Start, the treadbelt can be moved manually and the Met light will blink when a magnet is in front of sensor.  
Check sensor on all magnets.

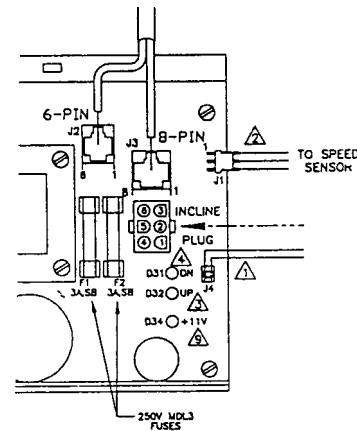

**VOLTAGE TO DRIVE MOTOR TEST**

This test is used to diagnose conditions of No Belt Movement, or Speed Fluctuations

- Set voltmeter to Volts DC and adjust speed on Control Panel to 4mph
- Attach red voltmeter lead to MTR1 on PWM with motor wires attached
- Attach black voltmeter lead to MTR2 on PWM with motor wires attached
- 0 Vdc signals no PWM output
- 166 Vdc signals open circuit in motor or motor connection
- Operating voltage will lay between 0Vdc and 166 Vdc

NOTE: The reason that we do not narrow down PWM output voltage is that the PWM output is a pulse signal. The sampling rate of the voltmeter used will determine what output voltage the voltmeter is able to read.

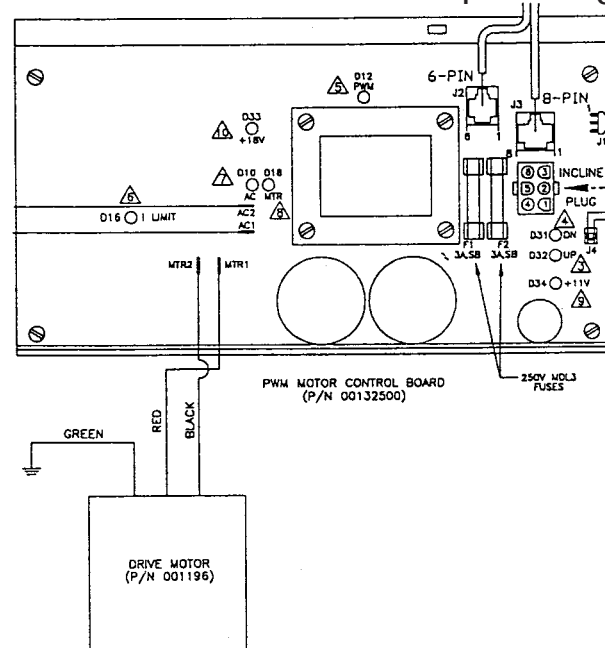

**DRIVE MOTOR TEST**

- This test is used in conditions of No Belt Movement.
- Unplug treadmill and set voltmeter to Volts DC
- Disconnect motor leads from PWM
- Place 1 voltmeter lead in each motor wire
- Gently spin motor flywheel and check for Voltage DC
- 2-5 Vdc means normal motor operation
- 0 Vdc means motor malfunction

**DRIVE BELT TENSION TEST**

- This test is used in front roller replacement and in conditions of Belt Slipping.
- Place two fingers on top of drive belt halfway between front roller and drive motor pulley.
- With moderate pressure push down on belt.
- If belt deflects down more than 1/4", tighten motor mount bolts
- If belt deflects down less than 1/4", loosen motor mount bolts

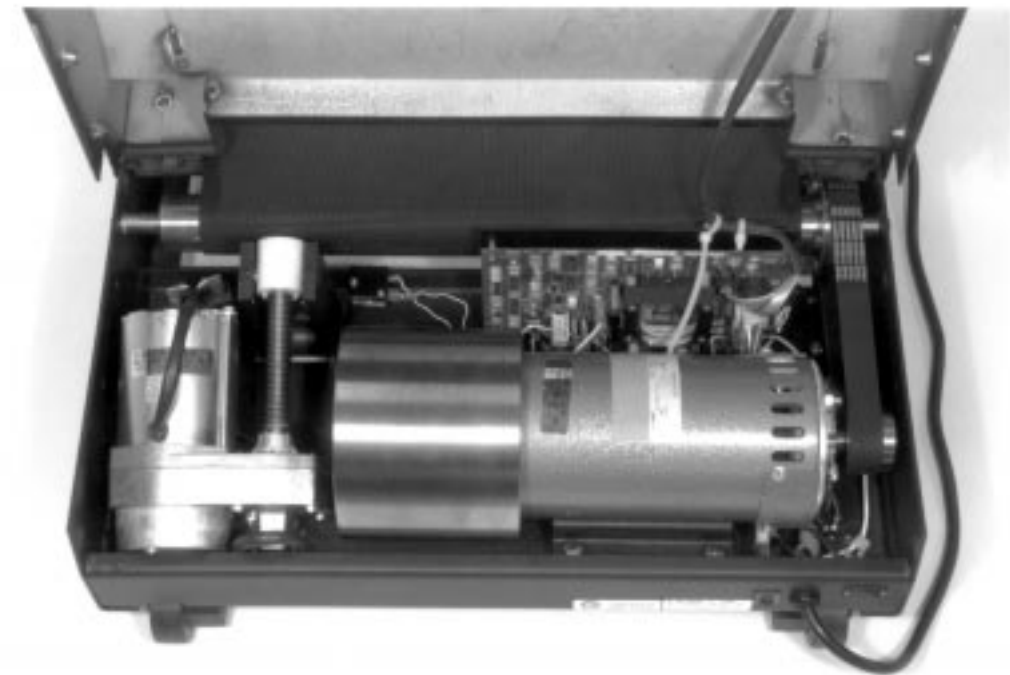

**TREADBELT TENSION TEST**

This test will address belt slipping and is used in any roller replacement or deck replacement. Ensure that the drive belt is properly tensioned before adjusting treadbelt tension. Belt and Deck wear and/or lack of lubrication can cause the treadbelt to show symptoms similar to loose treadbelt tension- check these conditions before adjusting treadbelt tension.

- Turn treadmill on and adjust speed to 2 mph
- Walk heavily on the belt pulling slightly against belt movement
- If hesitation or slip is detected, tighten treadbelt tension bolts 1/4 turn
- Repeat until no hesitation or slip is encountered. Check at higher speeds

Treadbelt tension is too tight if the belt feels stiff to touch with no give or the belt groans against rollers. You should be able to insert your hand between the belt and deck palm up almost to your thumb when the belt is at proper tension.



**INCLINE POTENTIOMETER CALIBRATION TEST**

This test can correct E1: Minimum conditions and aid in diagnosis of incline problems with finding zero or target incline.

- Set voltmeter to Ohms ( $\Omega$ ) with treadmill unplugged from wall
- Place 1 voltmeter lead on pin 3 (Blue) and 1 lead on pin 2 (Orange)
- Check for 800 Ohms
- In calibration mode before pressing Start, the Distance window displays the incline number. With the treadmill at zero, the number should be between 160 and 180. 0 often indicates a wire harness misconnection or failure of signal to panel. As the unit inclines during calibration, watch the numbers in the Distance window, if they do not increase by at least 60 from the zero value, an E1:Range error will result. Then the zero value may need to be reset to a lower value.
- If incline potentiometer needs adjustment, remove swivel pins and twist incline motor shaft by hand until the 800 Ohms is reached. See diagram on next page.

**VOLTAGE TO INCLINE MOTOR TEST**

This test is utilized in conditions of No Incline Movement, Incline Fluctuation, or E1: Stall. Set Voltmeter to AC Volts. To access incline plug, PWM screws may need to be removed.

- Place voltmeter leads across White and Black while pushing UP button
- 120 Vac indicates normal PWM output, 0Vac signals no output
- Place voltmeter leads across Red and White while pushing Down button
- 120 Vac indicates normal PWM output, 0Vac signals no output

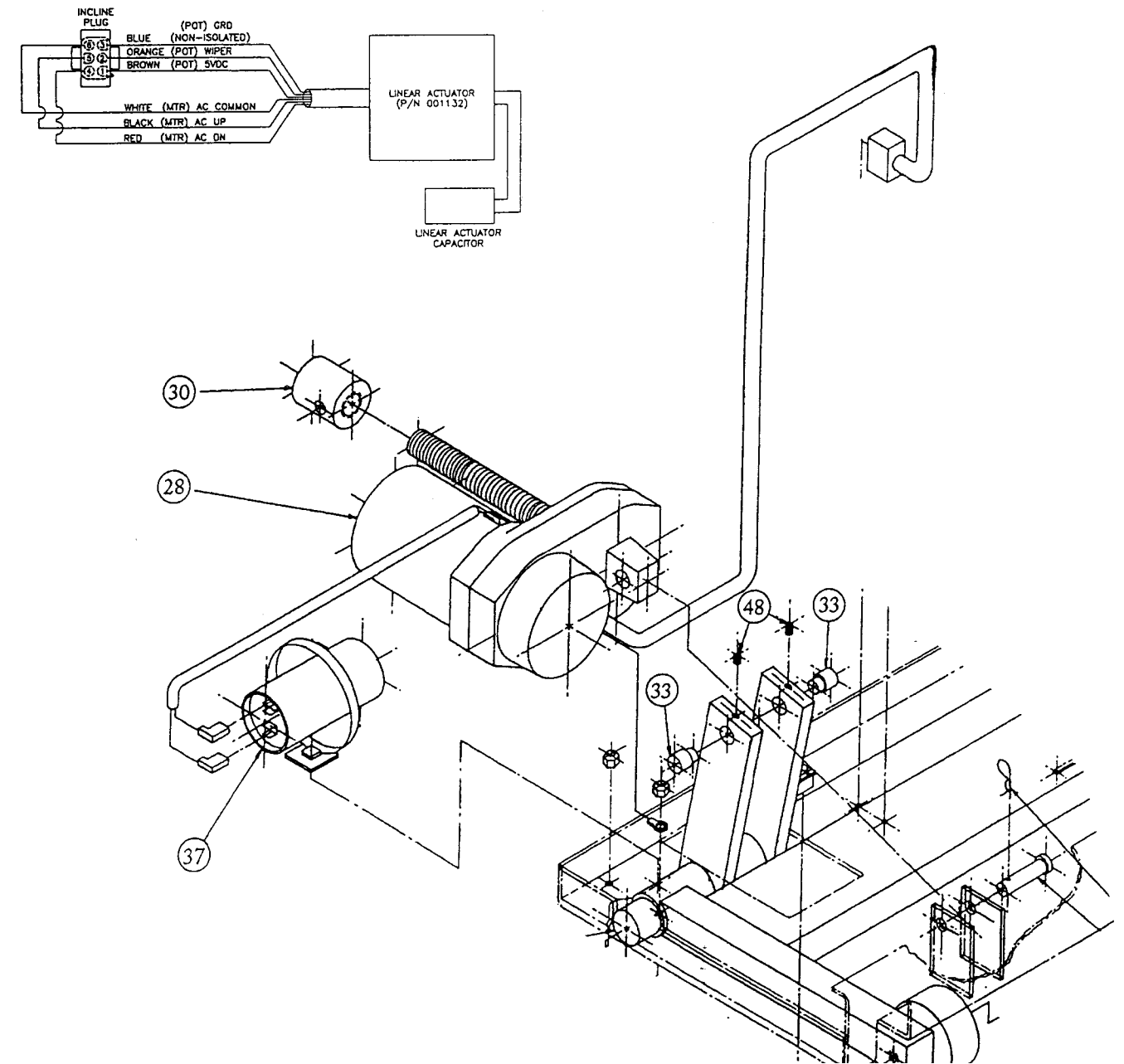

## INDIVIDUAL PERFORMANCE CHART

Photocopy this chart for repeated use and keep a weekly record of your performance progress.

NAME DATE	WORKOUT TIME	DISTANCE	AVERAGE SPEED	PROGRAM LEVEL	GOAL	TARGET HEART RATE			
1									
2									
3									
4									
5									
6									
7									
8									
9									
10									
11									
12									
13									
14									