



TUFFSTUFF WARRANTY

TuffStuff warrants to the original purchaser that TuffStuff equipment will be free from defects in material and workmanship. All warranty periods begin to run from the date of delivery to the original purchaser. The warranty and remedies set forth herein are conditioned upon proper storage, installation, use and maintenance and conformance with any recommendations of TuffStuff. This warranty does not cover products not manufactured by TuffStuff or products which are altered without the express written consent of TuffStuff. This warranty as specified:

FULL COMMERCIAL WARRANTY (more than 5 hours of use per day): a) Frames, welds, cams and weight plates -- Lifetime, b) Pivot bearings, pulleys, bushings, gas shocks and guide rods -- Five (5) years, c) Belts, linear bearings and pull-pin components -- One (1) year, and d) Upholstery, cables, finish and rubber grips -- Six (6) months.

LIGHT COMMERCIAL WARRANTY (less than 5 hours of use per day): a) Frames, welds, cams and weight plates -- Lifetime, b) Pivot bearings, pulleys, bushings, gas shocks and guide rods -- Five (5) years, c) Linear bearings, finish and pull-pin components -- One (1) year, and d) Upholstery, cables and rubber grips -- Three (3) months, and all other parts not mentioned elsewhere in this warranty will expire one (1) year from the date of delivery to the original purchaser. The obligation of TuffStuff under this warranty is limited to repairing or replacing warranted defective parts, as TuffStuff may elect, at TuffStuff's facility in Pomona, California, without charge to purchaser for either parts or labor. Purchaser is responsible for installation of repaired or replaced parts, and all transportation and insurance costs on returned or replaced equipment to and from TuffStuff's facility in Pomona.

THE FOREGOING SHALL CONSTITUTE THE SOLE REMEDY OF THE PURCHASER AND THE SOLE LIABILITY OF TUFFSTUFF WITH REGARD TO WARRANTY. NO IMPLIED STATUTORY WARRANTY OR IMPLIED STATUTORY WARRANTY OF MERCHANTABILITY OR FITNESS FOR A PARTICULAR PURPOSE SHALL APPLY. IN NO EVENT, WHETHER AS A RESULT OF BREACH OF CONTRACT, WARRANTY, NEGLIGENCE OR OTHERWISE, SHALL TUFFSTUFF BE LIABLE FOR SPECIAL, INCIDENTAL OR CONSEQUENTIAL DAMAGES INCLUDING, BUT NOT LIMITED TO, LOSS OF PROFITS OR REVENUE, LOSS OF USE OF EQUIPMENT, COST OF CAPITAL, COST OF SUBSTITUTION EQUIPMENT, DOWNTIME COST, OR CLAIMS OF CUSTOMERS OR PURCHASER FROM SUCH DAMAGE.

This written warranty is the final, complete and exclusive agreement of the parties with respect to the quality or performance of the equipment and no action for breach of this written warranty or any implied warranty shall be commenced more than one (1) year after the accrual of the cause of action. No modification of this warranty or waiver of its terms shall be binding on either party unless approved in writing by an authorized representative of the party. Contact TuffStuff Fitness Equipment, Inc. at 1325 E. Franklin Avenue, Pomona, California 91766, before returning any defective equipment.

TuffStuff Fitness Equipment, Inc.

1325 E. Franklin Avenue
Pomona, CA 91766, USA

Ph: 909-629-1600 Fax: 909-629-4967

E-mail: service@tuffstuff.net Net: www.tuffstuff.net

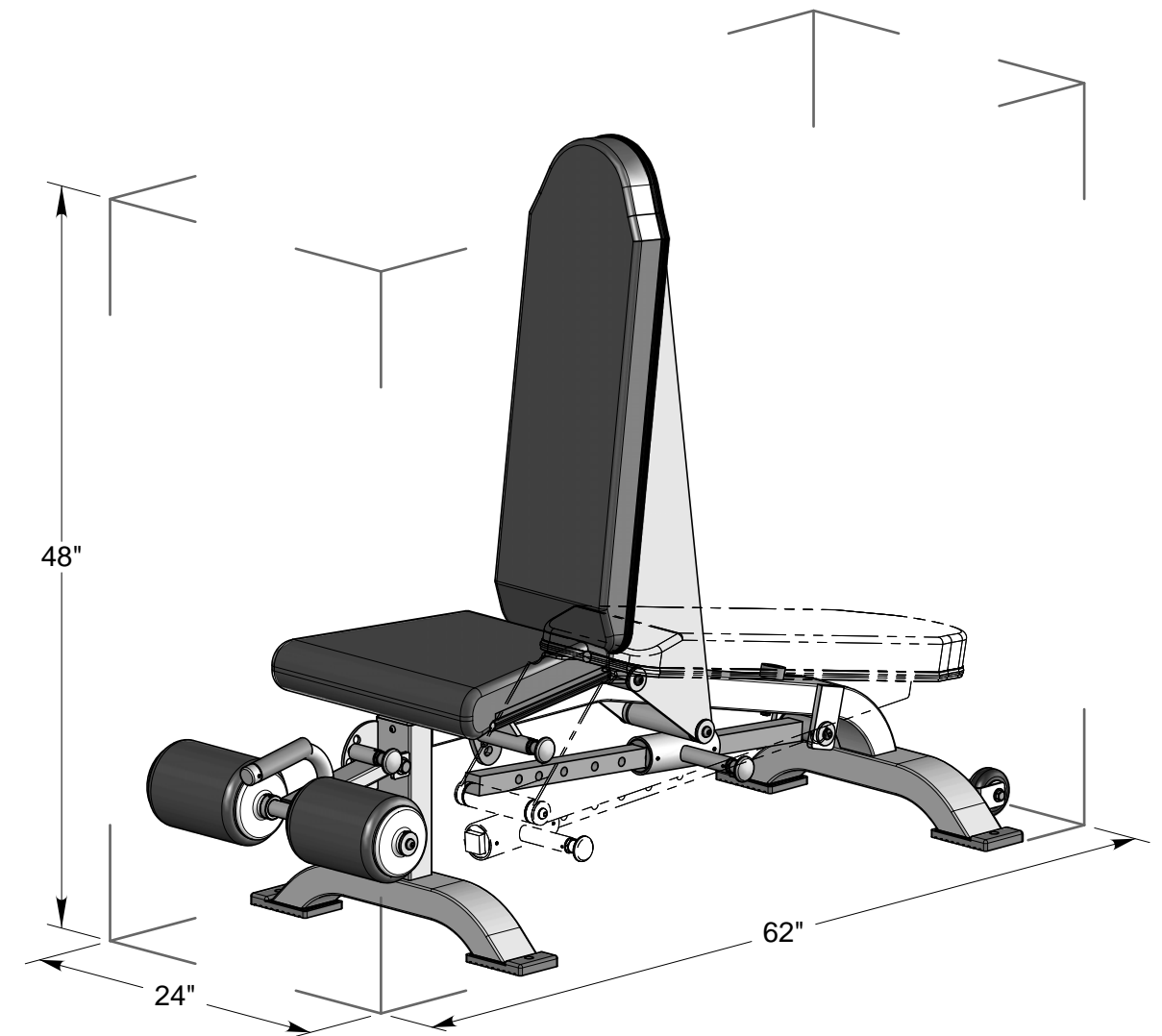

PF-300

Deluxe Multi-Purpose Bench W/Rolls



TuffStuff Fitness Equipment, Inc.

1325 E. Franklin Avenue
Pomona, CA 91766, USA

Ph: 909-629-1600 Fax: 909-629-4967

E-mail: service@tuffstuff.net Net: www.tuffstuff.net

AMERICA'S PREMIER EXERCISE EQUIPMENT

Introduction

About the PF-300 Deluxe Multi-Purpose Bench W/Rolls
 Congratulations on your new purchase of the **Deluxe Multi-Purpose Bench W/Rolls**. We hope you are completely satisfied with this product and wish you many years of enjoyment.

TuffStuff Equipment

This Tuffstuff product has been built to precise quality standards and has been carefully packaged to ensure that damage will not occur during shipment. The Limited Warranty and signature indicating final inspection has been conducted by our line foreman, is an expression of our confidence in the completeness, the materials, and workmanship of this product.

Warranty

SEE A COPY OF WARRANTY ON BACK PAGE.

Registration Card

To avoid unnecessary delays in warranty service and to insure that a permanent record of your purchase is on file with our factory, be sure to complete the warranty registration card and send it to TuffStuff Fitness Equipment today.

Specifications

1. Maximum Wt. Capacity - 500 lbs.
2. Total Machine Weight - 150 lbs.
3. Footprint (LWH) - See Front Cover.

Note: Due to continuing product improvements, specifications and designs are subject to change without notice.



TuffStuff Basic Strength Equipment Safety and General Maintenance

All TUFFSTUFF strength equipment is designed and manufactured to offer maximum, long-life service with minimal maintenance. However, safety inspection and routine maintenance in your facility should be the utmost importance in your daily operation. Information presented in these pages will serve as a basic guideline to design your own inspection procedures.

Part One: General Inspection and Cleaning

Equipment should be wiped down with a damp cloth and dried on a daily basis. The powder coat finish should be polished with a good car wax on a monthly basis. A daily wipe down of the upholstery with a lanolin based hand cleaner or Naugahyde Cleaner. Do not use cleaners such as Lysol or Windex as they will dry out and crack the vinyl. Lanolin hand cleaner dissolves the sweat and lubricates the vinyl, maintaining its natural flexibility. Sweat is corrosive and when left on the frame and components will eventually cause corrosion or rust. When performing these cleaning sessions, it is the perfect time to inspect the equipment and note any problems for the maintenance personnel to correct.

1. Check equipment if it is operating properly.
2. Check the cable for loose fittings or frayed cable and is seating properly on the pulleys and cams.
3. Make sure that the proper weight stack selector pin is with each machine and that the pin functions properly.
4. If something appears loose be sure to have it tightened immediately.
5. If a piece of equipment appears damaged or not operation properly, place the piece out-of-service immediately.



Prior to the Assembly of the Deluxe Multi-Purpose Bench W/Rolls

We advise you to consult your local TuffStuff retailer if you should have a question or problem regarding the proper assembly of this unit.

Tool Requirements

1. One 7/8" combination wrench
2. One 3/4" combination wrench
3. One 9/16" combination wrench
4. One ratchet
5. One 3/4" socket
6. One 9/16" socket
7. Rubber Mallet
8. Windex or household glass cleaner
9. Measuring tape
10. Utility knife

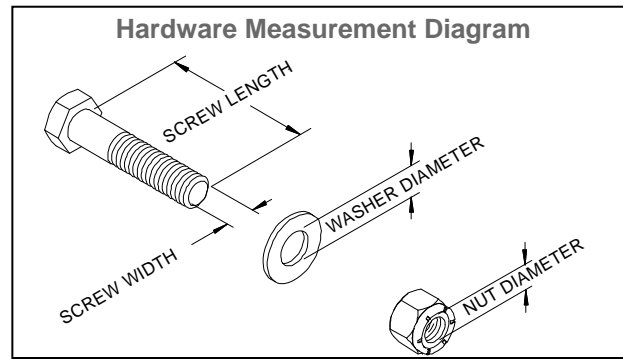

PF-300 Parts List



COLOR CHART

BOLD FONT = SUB-ASSEMBLY PARTS
 BLACK= HARDWARE

PF-300 Parts List

					REV0			
ITEM	DESCRIPTION	REV	PART NO.	QTY	ITEM	DESCRIPTION	PART NO.	QTY
1	ADJUSTABLE CARRIAGE	0	UP2399	1	28	DECAL-WARNING ATTENTION USERS!...	BNH1895	1
2	ADJUSTABLE FOOT ROLL BRACKET	0	UP2396	1	29	FLAT PHILLIPS SCREW ZINC # 2 X 1/2	BNH1480	2
3	ADJUSTABLE SELECTOR POST	0	UP2398	1	30	FLAT WASHER SAE B/O 1/2"	BNH0238	2
4	BACK PAD	0	UP3749	1	31	FLAT WASHER SAE B/O 3/8"	BNH0239	13
5	BACK PAD BRACKET LT	0	UP2401	1	32	HEX HEAD CAP SCREW GR-5 B/O 1/2-13 X 3 1/2	BNH0263	1
6	BACK PAD BRACKET RT	0	UP2400	1	33	HEX HEAD CAP SCREW GR-5 B/O 3/8-16 X 1 1/2	BNH0303	8
7	FOAM ROLL 1 X 5 1/2 X 7 1/4	0	UP0350	2	34	HEX HEAD CAP SCREW GR-5 B/O 3/8-16 X 2 1/2	BNH0276	2
8	MAIN FRAME	0	UP5378	1	35	HEX HEAD CAP SCREW GR-5 B/O 3/8-16 X 2 3/4	BNH0278	1
9	PIVOT AXLE 1 X 3 3/4	0	UP0468	1	36	HEX KEY ALLOY 3/32"	BNH0372	1
10	PIVOT AXLE 1 X 6 1/2	0	UP2403	1	37	HEX KEY ALLOY 5/32"	BNH0373	1
11	SEAT PAD	0	UP0490	1	38	HEX KEY ALLOY 7/32"	BNH0575	2
12	SEAT PAD BRACKET	0	UP2402	1	39	HEX KEY ALLOY 1/8"	BNH0767	1
13	SEAT PAD HINGE	0	UP2397	2	40	NYLON INSERT JAM LOCK NUT B/O 1/2-13	BNH0366	1
14	ALUMINUM CAP 1"		BNH0537	1	41	NYLON INSERT JAM LOCK NUT B/O 3/8-16	BNH0365	3
15	ALUM COLLAR 1.0312 ID X 1.521 OD X .500 THK.		BNH1519	2	42	PULL PIN 1/2 X 3 1/2 (YELLOW KNOB)	BNH0603	1
16	ALUM FOOT ROLL CAP 1 5/16 ID X 4 1/2 OD X 3/4		BNH1509	4	43	PULL PIN 1/2 X 5 5/8 LIGHT SPRING	BNH0701	2
17	ALUMINUM INSERT CAP 2 X 3		BNH1504	1	44	PVC 1 X 9	BNH1611	2
18	ALUM WASHER .390 ID X 1.500 OD X .150 THK		BNH1541	2	45	RUBBER BUMPER W/WASHER 3/8 X 1 1/2	BNH0514	1
19	BLACK WHEEL 3/8 X 3 X 1 1/4 W/BEARING		BNH0300	2	46	RUBBER FOOT 3 X 4 1/2	BNH0607	4
20	BRONZE BUSHING 1.003 ID X 1.245 OD X 3/4		BNH1144	12	47	RUBBER GRIP 1 X 4 1/2	BNH1062	1
21	BRONZE BUSHING 1/2 X 5/8 X 1/2 X 7/8 X 1/8		BNH0528	2	48	SOCKET SET SCREW ALLOY 10-32 X 1/4	BNH1522	4
22	BUTTON SOCKET CAP SCREW B/O 1/4-20 X 3/8		BNH1346	1	49	SOCKET SET SCREW ALLOY 10-32 X 1/8	BNH0473	13
23	BUTTON SOCKET CAP SCREW B/O 3/8-16 X 1		BNH0115	8	50	SOCKET SET SCREW ALLOY 1/4-20 X 3/8	BNH0772	2
24	CHROME WASHER 3/8 X 1 1/2		BNH1015	6	51	SPLIT LOCK WASHER B/O 3/8"	BNH0658	8
25	DECAL-CAUTION WEIGHT TRAINING SAFETY...		BNH0126	1	52	TEFLON BEARING 1.265 ID X 2.375 OD X 1.025	BNH1912	2
26	DECAL-DANGER TIGHTEN THIS RETAINING...		BNH0142	3	53	TUFFSTUFF LOGO ALUMINUM SMALL	BNH1323	1
27	DECAL-IMPORTANT FOR BEST PERFORMANCE...		BNH1894	1				

