

ASSEMBLY INSTRUCTIONS

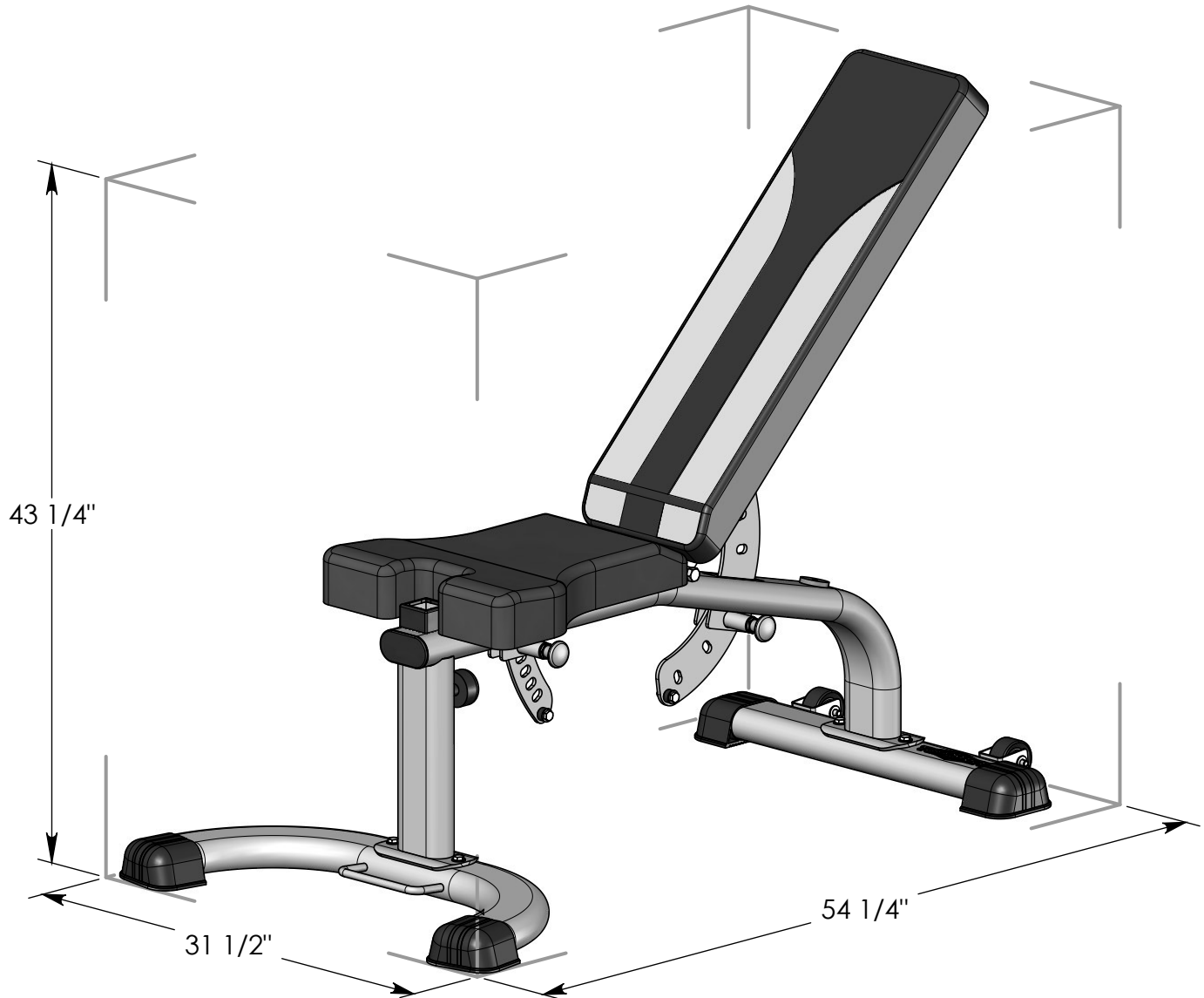

RMB-375

Multi-Purpose Bench



TuffStuff Fitness Equipment, Inc.

1325 E. Franklin Avenue
Pomona, CA 91766, USA

Ph: 909-629-1600 Fax: 909-629-4967

E-mail: service@tuffstuff.net Net: www.tuffstuff.net

AMERICA'S PREMIER EXERCISE EQUIPMENT

Introduction

About the RMB-375 Multi-Purpose Bench

Congratulations on your new purchase of the **Multi-Purpose Bench**. We hope you are completely satisfied with this product and wish you many years of enjoyment.

TuffStuff Equipment

This Tuffstuff product has been built to precise quality standards and has been carefully packaged to ensure that damage will not occur during shipment. The Home Lifetime Warranty and signature indicating final inspection has been conducted by our line foreman, is an expression of our confidence in the completeness, the materials, and workmanship of this product.

Registration Card

To avoid unnecessary delays in warranty service and to insure that a permanent record of your purchase is on file with our factory, be sure to complete the warranty registration card and send it to TuffStuff Fitness Equipment today.

Specifications

1. Maximum Wt. Capacity - 200 lbs.
2. Total Machine Weight - 95 lbs.
3. Footprint (LWH) - See Front Cover.

Note: Due to continuing product improvements, specifications and designs are subject to change without notice.

Prior to the Assembly of the Multi-Purpose Bench

We advise you to consult your local TuffStuff retailer if you should have a question or problem regarding the proper assembly of this unit.

Tool Requirements

1. One 7/8" combination wrench
2. One 3/4" combination wrench
3. One 9/16" combination wrench
4. One ratchet
5. One 3/4" socket
6. One 9/16" socket
7. Rubber Mallet
8. Windex or household glass cleaner
9. Utility knife

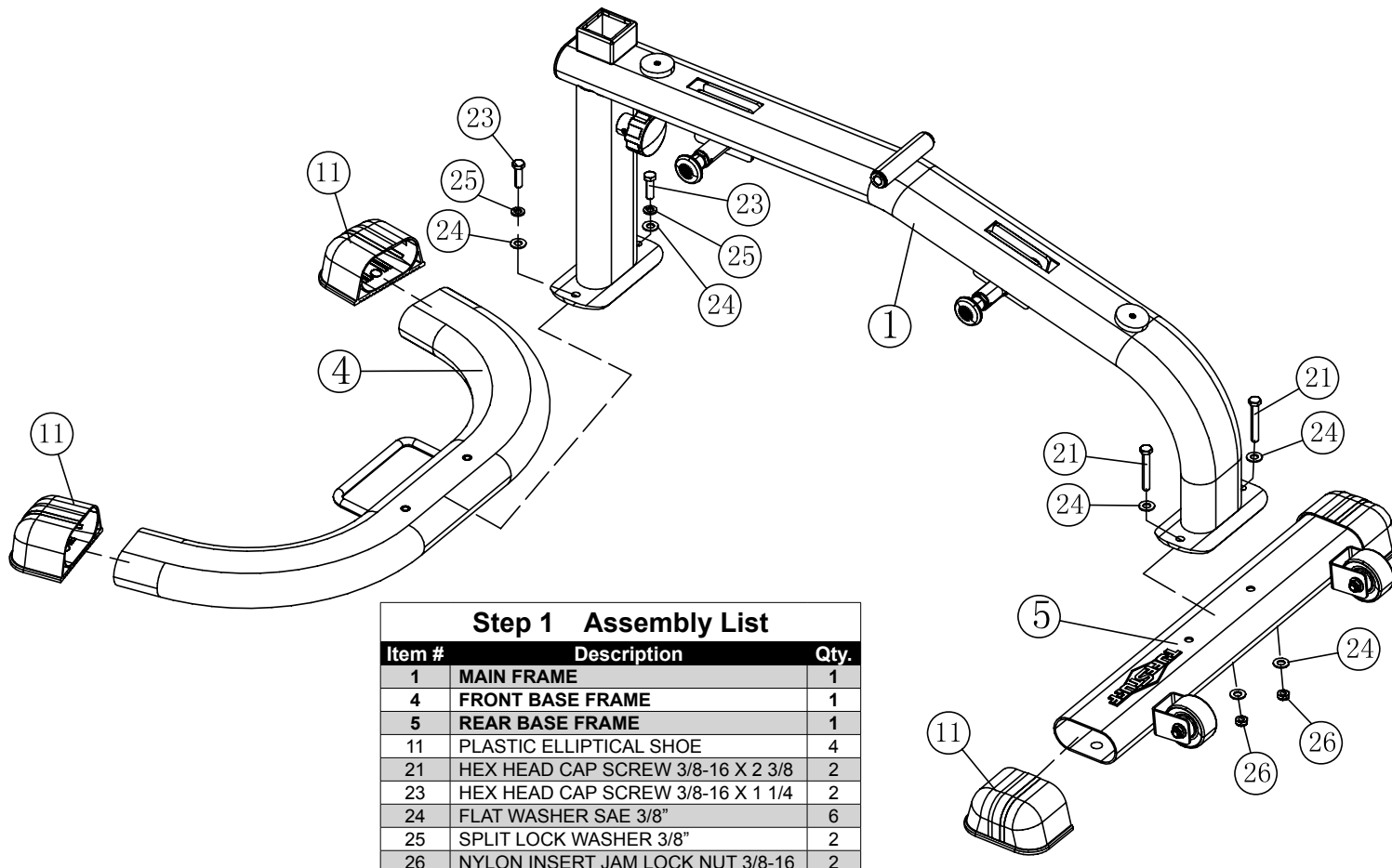
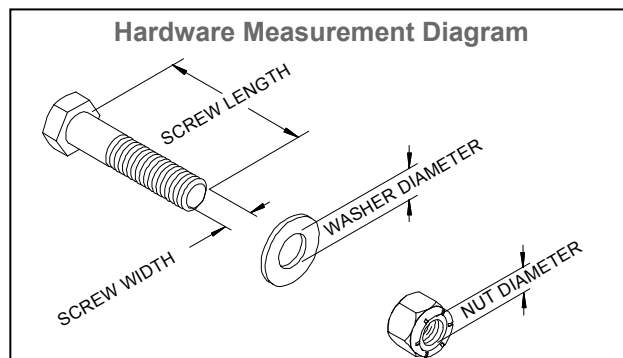

Step 1 Assembly List

Item #	Description	Qty.
1	MAIN FRAME	1
4	FRONT BASE FRAME	1
5	REAR BASE FRAME	1
11	PLASTIC ELLIPTICAL SHOE	4
21	HEX HEAD CAP SCREW 3/8-16 X 2 3/8	2
23	HEX HEAD CAP SCREW 3/8-16 X 1 1/4	2
24	FLAT WASHER SAE 3/8"	6
25	SPLIT LOCK WASHER 3/8"	2
26	NYLON INSERT JAM LOCK NUT 3/8-16	2

Step 2 Assembly List

Item #	Description	Qty.
2	BACK PAD BRACKET	1
3	SEAT PAD BRACKET	1
9	METAL HINGE	2
13	NYLON SPACER 3/8 X 3/4 X 3/8	2
22	HEX HEAD CAP SCREW 1/2-13 X 8 1/2	1
23	HEX HEAD CAP SCREW 3/8-16 X 1 1/4	2
24	FLAT WASHER SAE 3/8"	4
26	NYLON INSERT JAM LOCK NUT 3/8-16	2
27	NYLON INSERT JAM LOCK NUT 1/2-13	1

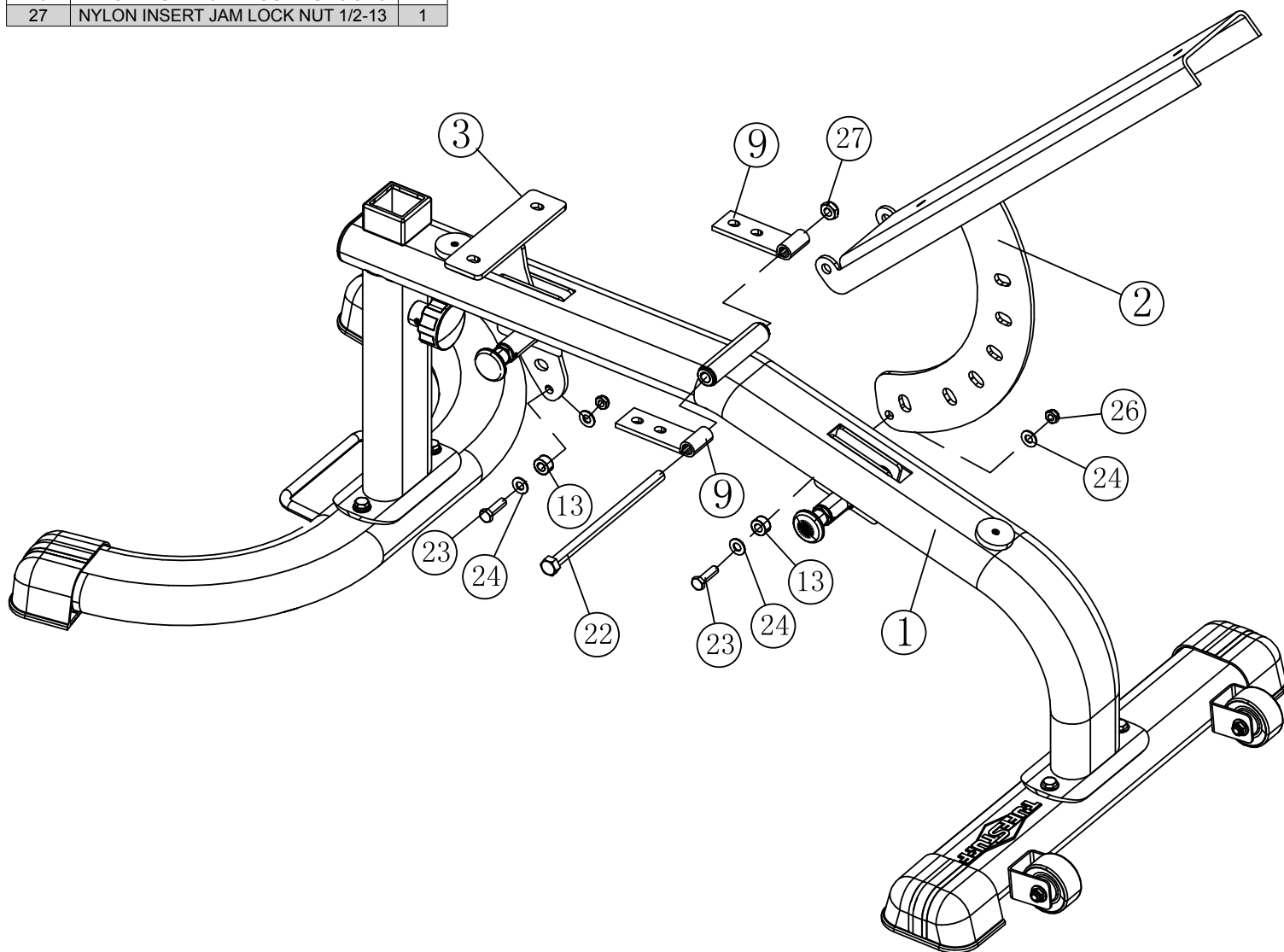

COLOR CHART

BOLD FONT = SUB-ASSEMBLY PARTS

BLACK= HARDWARE

**RMB-375
Parts List**



					REVO			
ITEM	DESCRIPTION	REV	PART NO.	QTY	ITEM	DESCRIPTION	PART NO.	QTY
1	MAIN FRAME	0	UP4973	1	18	TURN/PULL PIN W/KNOB AND LOCK	BNH0989	1
2	BACK PAD BRACKET	0	UP4974	1	19	FLAT PHILLIPS MACHINE SCREW 8-32 X 1/4	BNH0408	1
3	SEAT PAD BRACKET	0	UP4975	1	20	SOCKET SET SCREW ALLOY 10-32 X 1/8	BNH0473	2
4	FRONT BASE FRAME	0	UP4976	1	21	HEX HEAD CAP SCREW GR-5 Z/P 3/8-16 X 2 3/8	BNH2043	4
5	REAR BASE FRAME	0	UP4977	1	22	HEX HEAD CAP SCREW GR-5 Z/P 1/2-13 X 8 1/2	BNH2087	1
6	PULL PIN 1/2 X 3 1/2 (YELLOW)		BNH0603	2	23	HEX HEAD CAP SCREW GR-5 Z/P 3/8-16 X 1 1/4	BNH2038	10
7	BACK PAD	0	UP4978	1	24	FLAT WASHER SAE Z/P 3/8"	BNH2030	20
8	SEAT PAD	0	UP4979	1	25	SPLIT LOCK WASHER Z/P 3/8"	BNH2032	2
9	METAL HINGE		BNH0046	2	26	NYLON INSERT JAM LOCK NUT Z/P 3/8-16	BNH2026	6
10	BRONZE BUSHING 1/2 X 5/8 X 1/2 X 7/8 X 1/8		BNH0528	2	27	NYLON INSERT JAM LOCK NUT Z/P 1/2-13	BNH2027	1
11	PLASTIC HORIZONTAL ELLIPTICAL SHOE		BNH1847	4	28	FLAT PHILLIPS SCREW ZINC # 2 X 1/2	BNH1480	2
12	URETHANE BUMPER 1 3/4		BNH0229	2	29	HEX KEY ALLOY 3/32"	BNH0372	1
13	NYLON SPACER 3/8 X 3/4 X 3/8		BNH0392	2	30	TUFFSTUFF LOGO ALUMINUM SMALL	BNH1323	1
14	NYLON STEM BUTTON (26 X 9.5 X 2.67 X 12.6)		BNH0569	4	31	DECAL-CAUTION WEIGHT TRAINING SAFETY...	BNH0126	1
15	PLASTIC TUBE GUIDE W/LIP 2" SQ		BNH0058	1	32	DECAL-DANGER TIGHTEN THIS RETAINING...	BNH0142	2
16	PLASTIC INSERT CAP ELLIPTICAL 2 X 4		BNH1794	1	33	DECAL-WARNING ATTENTION USERS! MOVING...	BNH1895	1
17	BLACK WHEEL 3/8 X 3 X 1 1/4 W/BEARING		BNH0300	2				

